

**MARKETING SALES DRAWING**

**DIMENSIONS IN INCHES - DO NOT SCALE THIS DRAWING**  
**DIMENSIONS IN METRIC - [ ]**

This drawing is the property of Tusonix, Inc., and may not be used, reproduced, published or disclosed to others without expressed authorization by Tusonix Inc.

**Electrical Testing**  
**per Tusonix standard**  
**test plans and Mil-Std-202**  
**Test Methods.**

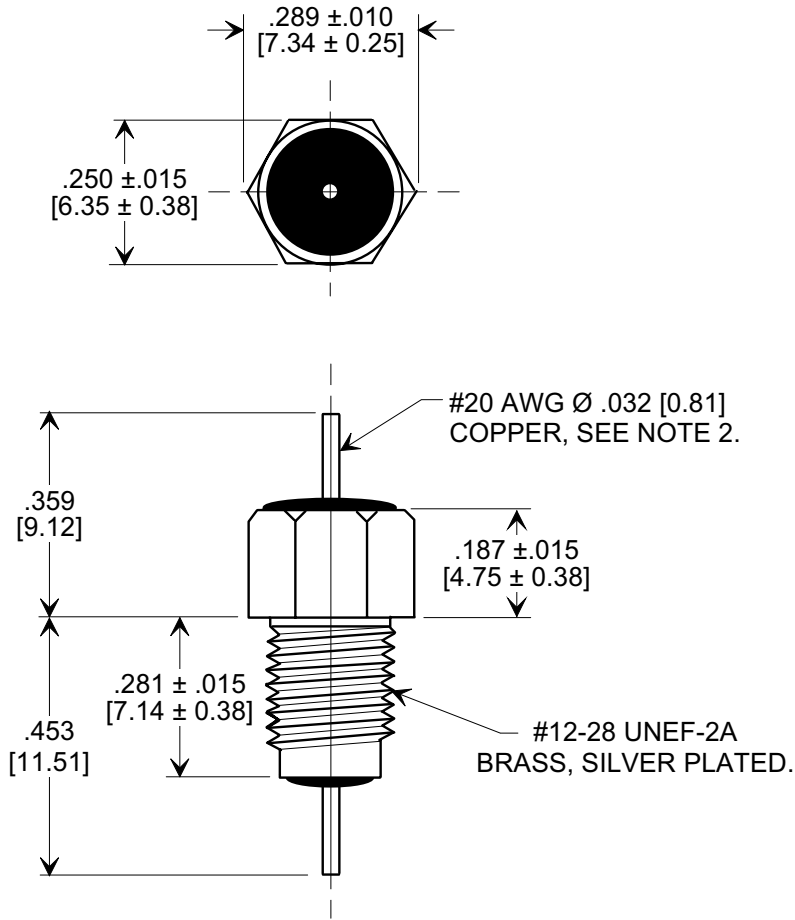
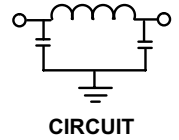
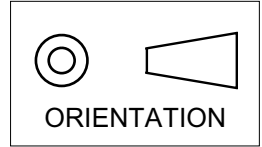

**NOTES:**

- TUSONIX STANDARD PART NUMBER: 4204-050.  
 TUSONIX RoHS COMPLIANT PART NUMBER: 4204-050 LF.  
 CUSTOMER MUST SPECIFY STANDARD OR RoHS PART NUMBER WHEN ORDERING.
- LEAD FINISH: STANDARD PART #: 60/40 SOLDER PLATED. RoHS PART #: SILVER PLATED.
- PART MARKING: TRADEMARK AND VARIATION NUMBER ON HEX FLATS.  
 STANDARD PART: BLACK INK. RoHS PART: GREEN INK.
- SUPPLIED WITH SILVER PLATED COPPER ALLOY HEX NUT AND INTERNAL TOOTH LOCK WASHER.

MIN. CAP. (pF)	WORKING VOLTAGE (VDC)		CURRENT (Idc)	I.R. MIN. @ 100 (VDC)	DWV (VDC)	MINIMUM NO LOAD INSERTION LOSS (dB) AT 25°C PER MIL-STD -220			
	85°C	125 °C				10 MHz	100 MHz	1 GHz	10 GHz
5000	200	100	10 A	10 G Ω	400	20	65	70	70

X-2015 Rev-0 <b>REVISION RECORD</b> Original Release C.O. <b>2898</b> RDN TO COMP FMT & ADDED METRIC. 02-12-02 <b>20020522-6-07</b> ADDED NOTES, IR & DWV. S.M. 02-20-06 <b>20060109-2-10</b>	<b>0</b>	<b>--TOLERANCES--</b> Unless Otherwise Specified <hr/> DECIMAL ± .031 [0.79] <hr/> ANGLES ±	Title <b>BUSHING STYLE EMI FILTER</b>	
	<b>1</b>		Drawn S.M. 05-22-02	Scale <b>3 X</b>
	<b>2</b>		Approved J.Mc. 05-22-02	
	<b>TUSONIX</b> TUCSON, ARIZONA		<b>A</b>	<b>4204-050</b>