

THIS DRAWING IS UNPUBLISHED. RELEASED FOR PUBLICATION
 © COPYRIGHT - By - ALL RIGHTS RESERVED.

LOC		DIST		REVISIONS			
P	LTR	DESCRIPTION	DATE	DWN	APVD		
GP	00						
	Z1	REVISED PER ECO-11-004835	11MAR11	RK	HMR		

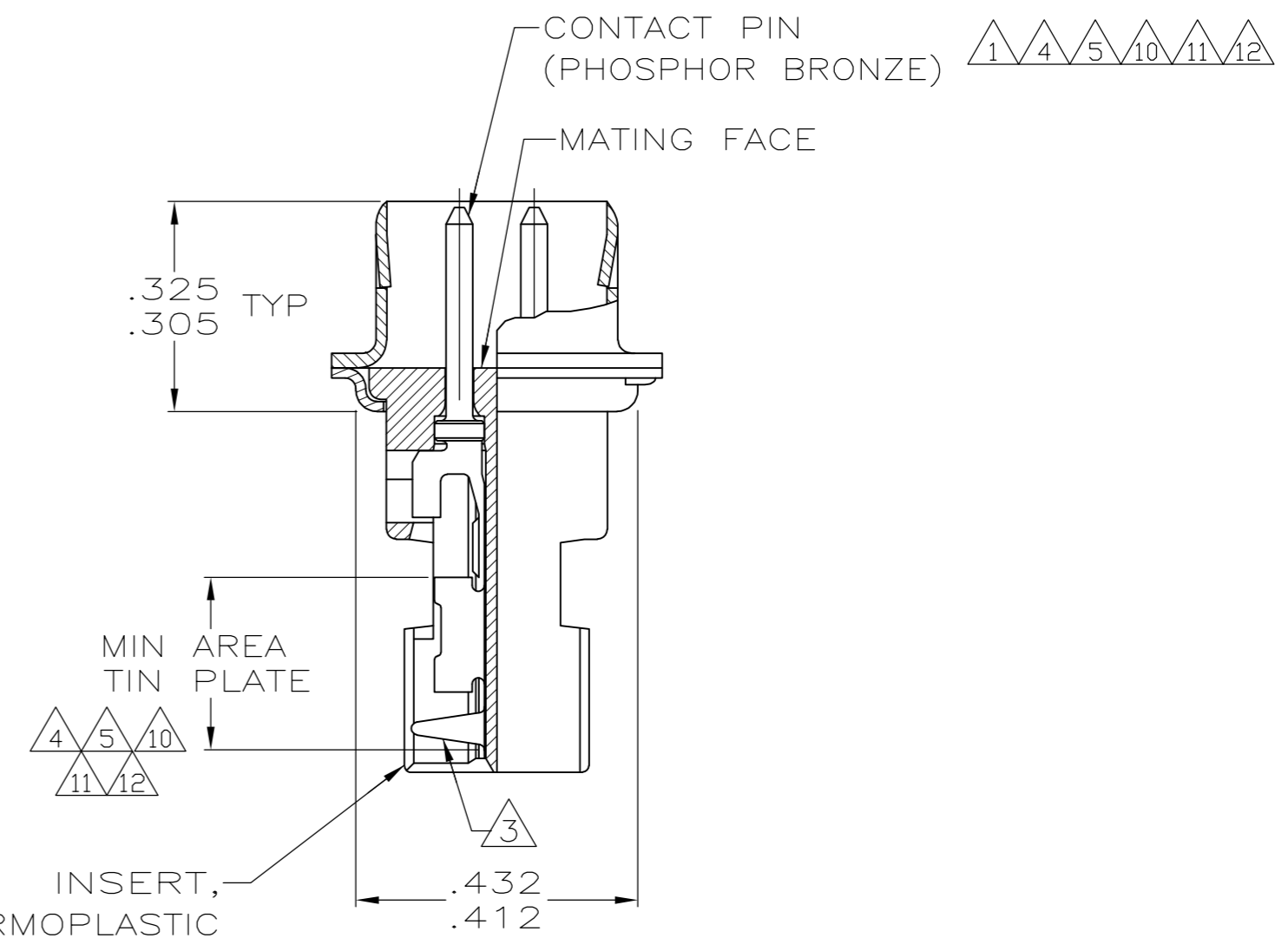
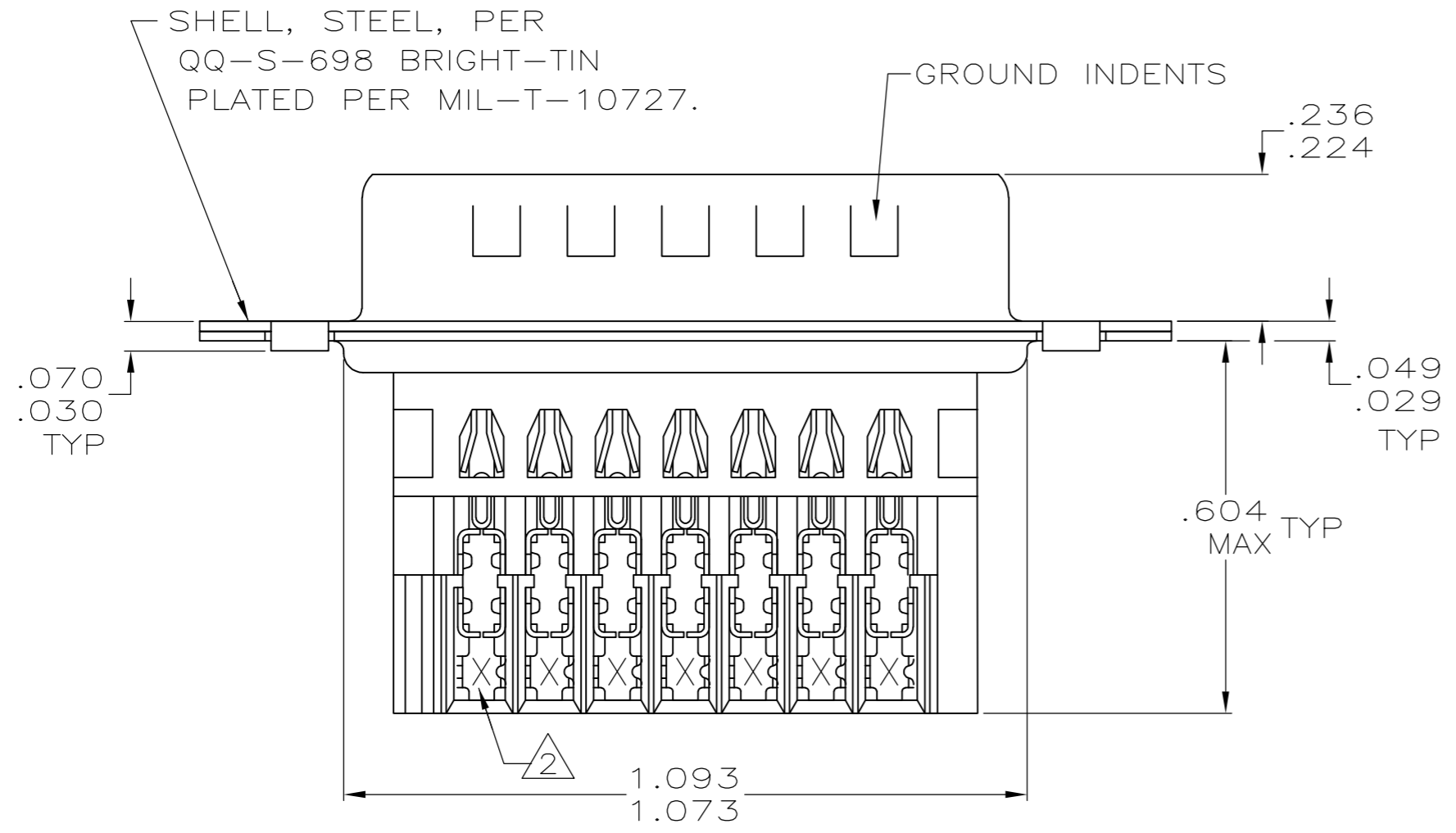
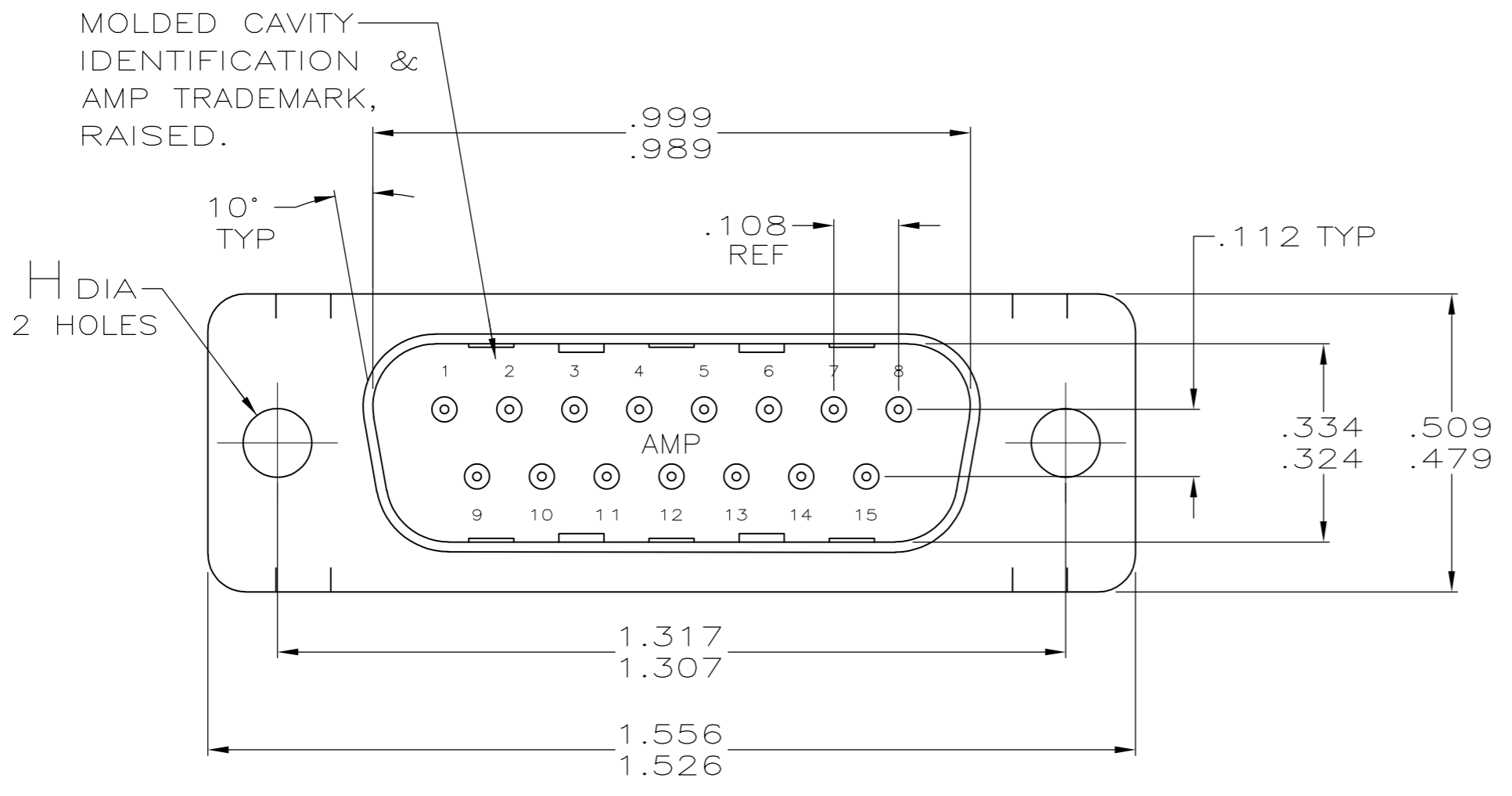

THIS DRAWING IS A CONTROLLED DOCUMENT.		DWN	L. VARELA - DOCK5	11-16-04		TE Connectivity		
DIMENSIONS: INCHES		CHK	J. GERACE	11-16-04		NAME		
TOLERANCES UNLESS OTHERWISE SPECIFIED:		APVD	M. WALMSLEY	11-16-04		PRODUCT SPEC		
0 PLC ± - 1 PLC ± - 2 PLC ± - 3 PLC ± .005 4 PLC ± - ANGLES ± 2°		APPLICATION SPEC		108-40011				
MATERIAL SEE CALL OUT		FINISH SEE TABLES		WEIGHT -		SIZE A2		
		CUSTOMER DRAWING		CAGE CODE 00779		DRAWING NO C-745494		
				SCALE 4:1		SHEET 1 OF 2		
						REV Z1		

THIS DRAWING IS UNPUBLISHED. RELEASED FOR PUBLICATION
 © COPYRIGHT - By - ALL RIGHTS RESERVED.

LOC	DIST	REVISIONS			
P	LTR	DESCRIPTION	DATE	DWN	APVD
GP	00				
		SEE SHEET 1			

- 1 HOUSING FULLY LOADED WITH CONTACTS.
- 2 NUMBER ON CONTACT INDICATES WIRE RANGE.
- 3 CONTACT INSULATION RANGE: .060 MAXIMUM O.D.
- 4 CONTACTS GOLD PLATED FOR A LENGTH OF .150 MIN FROM MATING END, .000030 MIN GOLD IN MATED AREA, .000100-.000200 BRIGHT TIN OR BRIGHT TIN-LEAD IN AREA SHOWN, ALL OVER .000050 MIN NICKEL UNDERPLATE ON ENTIRE CONTACT.
OR
CONTACTS GOLD PLATED FOR A LENGTH OF .150 MIN FROM MATING END, GOLD FLASH OVER .000030 MIN PALLADIUM-NICKEL IN MATED AREA, .000100-.000200 BRIGHT TIN OR BRIGHT TIN-LEAD IN AREA SHOWN, ALL OVER .000050 MIN NICKEL UNDERPLATE ON ENTIRE CONTACT.
- 5 GOLD PLATED FOR LENGTH OF .150 MIN FROM MATING END, GOLD FLASH IN MATED AREA. .000100-.000200 BRIGHT TIN OR BRIGHT IN TIN-LEAD AREA SHOWN. .000030 NICKEL UNDERPLATE ON ENTIRE CONTACT.
- 6 OBSOLETE PART NUMBER.
- 7 GOLD PLATED FOR LENGTH OF .150 MIN FROM MATING END, .000050 MIN GOLD IN MATED AREA. .000100-.000200 BRIGHT TIN OR BRIGHT IN TIN-LEAD AREA SHOWN. .000050 NICKEL UNDERPLATE ON ENTIRE CONTACT.
- 9 SUPERSEDED BY 745494-5.
- 10 CONTACTS GOLD PLATED FOR A LENGTH OF .150 MIN FROM MATING END, .000030 MIN GOLD IN MATED AREA, .000100-.000200 MATTE TIN IN AREA SHOWN, ALL OVER .000050 MIN NICKEL UNDERPLATE ON ENTIRE CONTACT.
OR
CONTACTS GOLD PLATED FOR A LENGTH OF .150 MIN FROM MATING END, GOLD FLASH OVER PALLADIUM-NICKEL, .000030 MIN TOTAL IN MATED AREA, .000100-.000200 MATTE TIN IN AREA SHOWN, ALL OVER .000050 MIN NICKEL UNDERPLATE ON ENTIRE CONTACT.
- 11 CONTACTS PLATED GOLD FLASH FOR A LENGTH OF .150 MIN FROM MATING END, .000100-.000200 MATTE TIN IN AREA SHOWN, ALL OVER .000030 MIN NICKEL UNDERPLATE ON ENTIRE CONTACT.
- 12 CONTACTS GOLD PLATED FOR A LENGTH OF .150 MIN FROM MATING END, .000050 MIN GOLD IN MATED AREA, .000100-.000200 MATTE TIN IN AREA SHOWN, ALL OVER .000050 MIN NICKEL UNDERPLATE ON ENTIRE CONTACT.
OR
CONTACTS GOLD PLATED FOR A LENGTH OF .150 MIN FROM MATING END, GOLD FLASH OVER PALLADIUM-NICKEL, .000050 MIN TOTAL IN MATED AREA, .000100-.000200 MATTE TIN IN AREA SHOWN, ALL OVER .000050 MIN NICKEL UNDERPLATE ON ENTIRE CONTACT.

STANDARD	.156 .146	12	2	#22-26	6 1-745494-9
STANDARD	.125 .115	12	2	#22-26	1-745494-8
STANDARD	.125 .115	10	1	#26-30	1-745494-7
STANDARD	.125 .115	11	2	#22-26	1-745494-6
STANDARD	.125 .115	10	2	#22-26	1-745494-5
STANDARD	.125 .115	7	2	#22-26	6 1-745494-4
SMALL PACK	.125 .115	5	2	#22-26	9 1-745494-3
STANDARD	.156 .146	7	2	#22-26	6 1-745494-2
		5	2	#22-26	6 1-745494-1
STANDARD	.156 .146	4	1	#26-30	6 1-745494-0
			3	#20-22	6 745494-9
			2	#22-26	6 745494-8
STANDARD	.125 .115	5	1	#26-30	6 745494-7
			2	#22-26	6 745494-6
			1	#22-26	6 745494-5
STANDARD	.125 .115	4	1	#26-30	6 745494-4
			2	#22-26	6 745494-3
			1	#22-26	6 745494-2
PACKAGING	H	CONTACT FINISH	2	AWG WIRE RANGE	PART NUMBER

745494

THIS DRAWING IS A CONTROLLED DOCUMENT.

DIMENSIONS: INCHES	TOLERANCES UNLESS OTHERWISE SPECIFIED: 0 PLC ± - 1 PLC ± - 2 PLC ± - 3 PLC ± .005 4 PLC ± - ANGLES ± 2°	DWN 11-16-04 L. VARELA - DOCK5 CHK 11-16-04 J. GERACE APVD 11-16-04 M. WALMSLEY	NAME TE Connectivity
MATERIAL SEE CALL OUT	FINISH SEE TABLES	PRODUCT SPEC 108-40011 APPLICATION SPEC 114-40002	PLUG ASSEMBLY, METAL SHELL, SIZE 2, 15 POSITION, SERIES HDE-20 FOR MASS TERMINATION
		WEIGHT -	SIZE A2 CAGE CODE 00779 C=745494
		CUSTOMER DRAWING	RESTRICTED TO - SCALE 4:1 SHEET 2 of 2 REV Z1