

2A Ultra-Low Dropout Voltage LDO Regulators with Soft-Start

General Description

The RTQ2522A/B is a very low dropout linear regulator which operates from input voltage as low as 0.8V. The device is capable of supplying 2A of output current with a typical dropout voltage of only 90mV. A VBIAS supply is required to run the internal reference and LDO circuitry while output current comes directly from the VIN supply for high efficiency regulation. User-programmable soft-start limits the input inrush current and minimizes stress on the input power. The enable input and power good output allow easy sequencing with external regulators. This complete flexibility provides an easy-to-use robust power management solution for a wide variety of applications.

The RTQ2522A/B is stable with output capacitor greater than or equal to 2.2μF. A precise reference and error amplifier deliver 2% accuracy over load, line and temperature. Over-current limit and over-temperature protection are also included. The RTQ2522A/B is available in the WDFN-10L 3x3 and WQFN-20L 5x5 packages.

Applications

- PCs, Servers, Modems, and Set-Top-Boxes
- FPGA Applications
- DSP Core and I/O Voltages
- Instrumentation
- Post-Regulation Applications
- Applications With Sequencing Requirements

Features

- **Ultralow V_{IN} Range : 0.8V to 5.5V**
- **VBIAS Voltage Range : 2.7V to 5.5V**
- **VOUT Voltage Range : 0.8V to 3.6V**
- **Low Dropout : 90mV Typ at 2A, $V_{BIAS} = 5V$**
- **2% Accuracy Over Line/Load/ Temperature**
- **PGOOD Indicator for Easy Sequence Control**
- **Programmable Soft-Start Provides Linear Voltage Startup**
- **Stable with Any Output Capacitor $\geq 2.2\mu F$**
- **Over-Current and Over-Temperature Protection**

Ordering Information

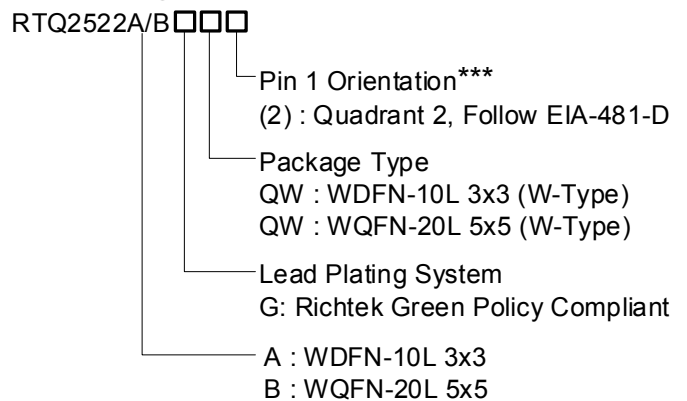

Note :

***Empty means Pin1 orientation is Quadrant 1

Richtek products are Richtek Green Policy compliant and compatible with the current requirements of IPC/JEDEC J-STD-020.

Simplified Application Circuit

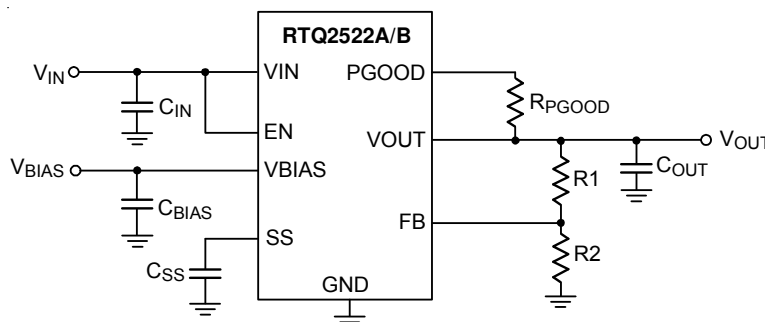

Pin Configuration

(TOP VIEW)

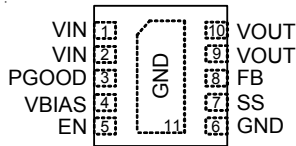

WDFN-10L 3x3

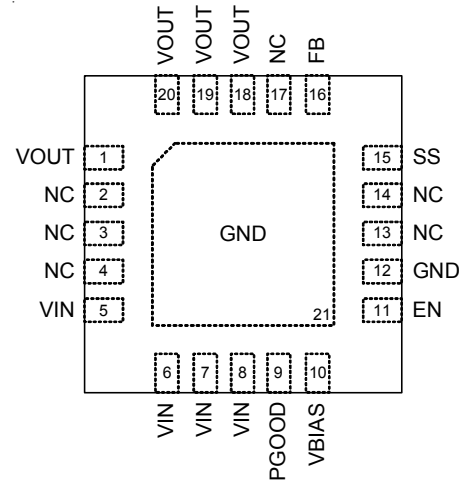

WQFN-20L 5x5

Marking Information

RTQ2522AGQW

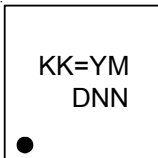

KK= : Product Code
YMDNN : Date Code

RTQ2522BGQW

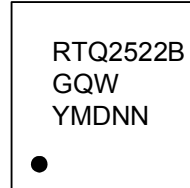

RTQ2522BGQW : Product Number
YMDNN : Date Code

Functional Pin Description

Pin No.		Pin Name	Pin Function
WDFN-10L 3x3	WQFN-20L 5x5		
1, 2	5, 6, 7, 8	VIN	Power input of the device.
9, 10	1, 18, 19, 20	VOUT	Regulated output voltage. A minimum of 2.2 μ F capacitor should be placed directly at this pin.
3	9	PGOOD	Power good indicator. An open-drain, active-high output that indicates the status of VOUT. A pull-up resistor from 10k Ω to 1M Ω should be connected from this pin to a supply of up to 5.5V.
4	10	VBIAS	Bias input pin. Providing input voltage for internal control circuitry.
5	11	EN	Chip enable (Active-High). Pulling this pin below 0.4V turns the regulator off, reducing the quiescent current to a fraction of its operating value. Connect to VIN if not being used.
6, 11 (Exposed Pad)	12, 21 (Exposed Pad)	GND	Ground. The Exposed Pad must be soldered to a large PCB and connected to GND for maximum power dissipation.
7	15	SS	Connect a capacitor between this pin and the ground to set the soft-start ramp time of the output voltage.

Pin No.		Pin Name	Pin Function
WDFN-10L 3x3	WQFN-20L 5x5		
8	16	FB	Feedback pin. Connect this pin to an external voltage divider to set the output voltage.
--	2, 3, 4, 13, 14, 17	NC	No internal connection. This pin can be left floating or connected to GND.

Functional Block Diagram

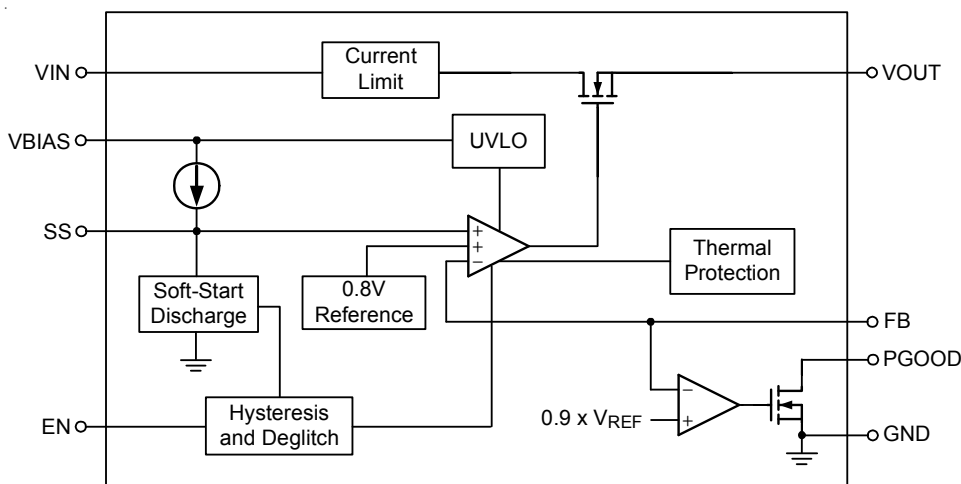

Operation

The RTQ2522A/B is a very low dropout linear regulator which operates from input voltage as low as 0.8V. It provides a highly accurate output that is capable of supplying 2A of output current with a typical dropout voltage of only 90mV. Output voltage range is from 0.8V to 3.6V.

VIN and VBIAS Supply

The VBIAS input supplies the internal reference and LDO circuitry while all output current comes directly from the VIN input for high efficiency regulation. With external VBIAS 3.25V above VOUT, offers the RTQ2522A/B very low dropout performance (140mV Max. at 2A) which allows the device to be used in place of a DC-DC converter and still achieve good efficiency. This provides designers to achieve the smallest, simplest, and lowest cost solution.

For applications where an auxiliary bias voltage is not

available or low dropout is not required. In these applications, VBIAS is suggested be 1.8V above VOUT and attention on power rating and thermal is needed.

Enable and Shutdown

The EN pin is active high. Apply a voltage above 1.1V ensures the LDO regulator turns on, while the regulator turns off if the V_{EN} belows 0.4V. The enable circuitry has typical 50mV hysteresis and deglitching for use with relatively slowly ramping analog signals. That helps avoid on-off cycling as a result of small glitches in the V_{EN} signal. A fast rise-time signal must be used to enable the RTQ2522A/B if precise turn-on timing is required. If not used, EN can be connected to either VIN or VBIAS. If EN is connected to VIN, it should be connected as close as possible to the largest capacitance on the input to prevent voltage droops on that line from triggering the enable circuit.

Soft-Start

The RTQ2522A/B includes a soft-start feature to prevent excessive current flow during start-up. When the LDO is enabled, an internal soft-start current (I_{SS}) charges the external soft-start capacitor (C_{SS}) to build a ramp-up voltage internally. The RTQ2522A/B achieve a linear and monotonic soft-start by tracking the voltage ramp until the voltage exceeds the internal reference. The soft-start ramp time can be calculated using Equation 1 :

$$t_{SS}(s) = \frac{V_{REF} \times C_{SS}}{I_{SS}} = \frac{0.8V \times C_{SS}(F)}{0.44\mu A} \quad (1)$$

Power GOOD

When the output voltage is greater than $V_{IT} + V_{HYS}$, the output voltage is considered good and the open-drain PGOOD pin goes high impedance and is typically pulled high with external resistor. If V_{OUT} drops below V_{IT} or if V_{BIAS} drops below 1.9 V, the open-drain output turns on and pulls the PGOOD output low. The PGOOD pin also asserts when the device is disabled, OCP or OTP triggered.

Over-Current Protection

The RTQ2522A/B has built-in over-current protection. When over current (typ. 3A) is detected, the RTQ2522A/B foldback and limit the current at typical 2.25A. It allows the device to supply surges of up to 3A and prevent the device over-heating if short circuit happened.

Thermal Protection

At higher temperatures, or in cases where internal power dissipation causes excessive self heating on chip, the thermal shutdown circuitry will shut down the LDO when the junction temperature exceeds approximately 160°C. It will re enable the LDO once the junction temperature drops back to approximately 140°C. The RTQ2522A/B will cycle in and out of thermal shutdown without latch-up or damage until the overstress condition is removed. Long term overstress ($T_J > 125^\circ\text{C}$) should be avoided as it can degrade the performance or shorten the life of the part.

Absolute Maximum Ratings (Note 1)

- Supply Input Voltage, V_{IN} ----- -0.3V to 6V
- Other Pins ----- -0.3V to 6V
- Output Voltage, V_{OUT} ----- -0.3V to ($V_{IN} + 0.3V$)
- Power Dissipation, P_D @ $T_A = 25^\circ C$
 - WDFN-10L 3x3 ----- 3.27W
 - WQFN-20L 5x5 ----- 3.54W
- Package Thermal Resistance (Note 2)
 - WDFN-10L 3x3, θ_{JA} ----- 30.5°C/W
 - WDFN-10L 3x3, θ_{JC} ----- 7.5°C/W
 - WQFN-20L 5x5, θ_{JA} ----- 28.2°C/W
 - WQFN-20L 5x5, θ_{JC} ----- 7.1°C/W
- Junction Temperature ----- 150°C
- Lead Temperature (Soldering, 10 sec.) ----- 260°C
- Storage Temperature Range ----- -65°C to 150°C
- ESD Susceptibility (Note 3)
 - HBM (Human Body Model) ----- 2kV

Recommended Operating Conditions (Note 4)

- Supply Input Voltage ----- 0.8V to 5.5V
- Ambient Temperature Range ----- -40°C to 105°C

Electrical Characteristics

($V_{EN} = 1.1V$, $V_{IN} = V_{OUT} + 0.3V$, $V_{BIAS} = 5V$, $C_{BIAS} = 0.1\mu F$, $C_{IN} = C_{OUT} = 10\mu F$, $C_{SS} = 1nF$, $I_{OUT} = 50mA$, $T_A = -40^\circ C$ to $105^\circ C$, unless otherwise specified. Typical values are at $T_A = 25^\circ C$)

Parameter	Symbol	Test Conditions	Min	Typ	Max	Unit
Input Voltage	V_{IN}		$V_{OUT} + V_{DROP}$	--	5.5	V
VBIAS Pin Voltage	V_{BIAS}		2.7	--	5.5	V
Internal Reference	V_{REF}	$T_A = 25^\circ C$	0.796	0.8	0.804	V
Output Voltage Range	V_{OUT}	$V_{IN} = 5V$, $I_{OUT} = 2A$	V_{REF}	--	3.6	V
Accuracy		$2.97V \leq V_{BIAS} \leq 5.5V$, $50mA \leq I_{OUT} \leq 2A$	-2	± 0.5	2	%
Line Regulation	ΔV_{LINE}	$V_{OUT} (Normal) + 0.3 \leq V_{IN} \leq 5.5V$	--	0.03	--	%/V
Load Regulation	ΔV_{LOAD}	$50mA \leq I_{OUT} = 2A$	--	0.09		%/A
VIN Dropout Voltage	V_{DROP_VIN}	$I_{OUT} = 2A$, $V_{BIAS} - V_{OUT} (Normal) \geq 3.25V$	--	90	140	mV
VBIAS Dropout Voltage	V_{DROP_VBIAS}	$I_{OUT} = 2A$, $V_{IN} = V_{BIAS}$	--	1.55	1.8	V
Current Limit	I_{LIM}	$V_{OUT} = 80\% \times V_{OUT} (Normal)$	2.5	--	5.5	A

Parameter		Symbol	Test Conditions	Min	Typ	Max	Unit
Bias Pin Current		I _{BIAS}		--	1	2	mA
Shutdown Supply Current (I _{GND})		I _{SHDN}	V _{EN} = 0.4V	--	1	50	μA
Feedback Pin Current		I _{FB}		-1	0.15	1	μA
Power-Supply Rejection (V _{IN} to V _{OUT})	PSRR (Note 5)	1kHz, I _{OUT} = 1.5A, V _{IN} = 1.8V, V _{OUT} = 1.5V	--	60	--	dB	
		300kHz, I _{OUT} = 1.5A, V _{IN} = 1.8V, V _{OUT} = 1.5V	--	30	--		
Power-Supply Rejection (V _{BIAS} to V _{OUT})		1kHz, I _{OUT} = 1.5A, V _{IN} = 1.8V, V _{OUT} = 1.5V	--	50	--	dB	
		300kHz, I _{OUT} = 1.5A, V _{IN} = 1.8V, V _{OUT} = 1.5V	--	30	--		
Output Noise Voltage		Noise (Note 5)	100Hz to 100kHz, I _{OUT} = 1.5A, C _{SS} = 0.001μF	--	25 x V _{OUT}	--	μV _{RMS}
Minimum Startup Time		t _{STR} (Note 5)	R _{LOAD} for I _{OUT} = 1A, C _{SS} = open	--	200	--	μs
Soft-Start Charging Current		I _{SS}	V _{SS} = 0.4V	--	440	--	nA
Enable Input Voltage	Logic_High	V _{IH}		1.1	--	5.5	V
	Logic_Low	V _{IL}		0	--	0.4	
Enable Pin Hysteresis		V _{EN_HYS}		--	50	--	mV
Enable Pin Deglitch Time		V _{EN_DG}		--	20	--	μs
Enable Pin Current		I _{EN}	V _{EN} = 5V	--	0.1	1	μA
PGOOD Trip Threshold		V _{IT}	V _{OUT} decreasing	85	90	94	%V _{OUT}
PGOOD Trip Hysteresis		V _{HYS}		--	3	--	%V _{OUT}
PGOOD Output Low Voltage		V _{PGOOD_L}	I _{PGOOD} = 1mA (sinking), V _{OUT} < V _{IT}	--	--	0.3	V
PGOOD Leakage Current		I _{PGOOD_LK}	V _{PGOOD} = 5.25 V, V _{OUT} > V _{IT}	--	0.1	1	μA
Thermal Shutdown Temperature	T _{SD}	Shutdown, temperature increasing	--	165	--	°C	
		Reset, temperature decreasing	--	140	--		

Note 1. Stresses beyond those listed under “Absolute Maximum Ratings” may cause permanent damage to the device. These are stress ratings only, and functional operation of the device at these or any other conditions beyond those indicated in the operational sections of the specifications is not implied. Exposure to absolute maximum rating conditions may affect device reliability.

Note 2. θ_{JA} is measured under natural convection (still air) at T_A = 25°C with the component mounted on a high effective-thermal-conductivity four-layer test board on a JEDEC 51-7 thermal measurement standard. θ_{JC} is measured at the exposed pad of the package.

Note 3. Devices are ESD sensitive. Handling precaution is recommended.

Note 4. The device is not guaranteed to function outside its operating conditions.

Note 5. Guaranteed by design.

Typical Application Circuit

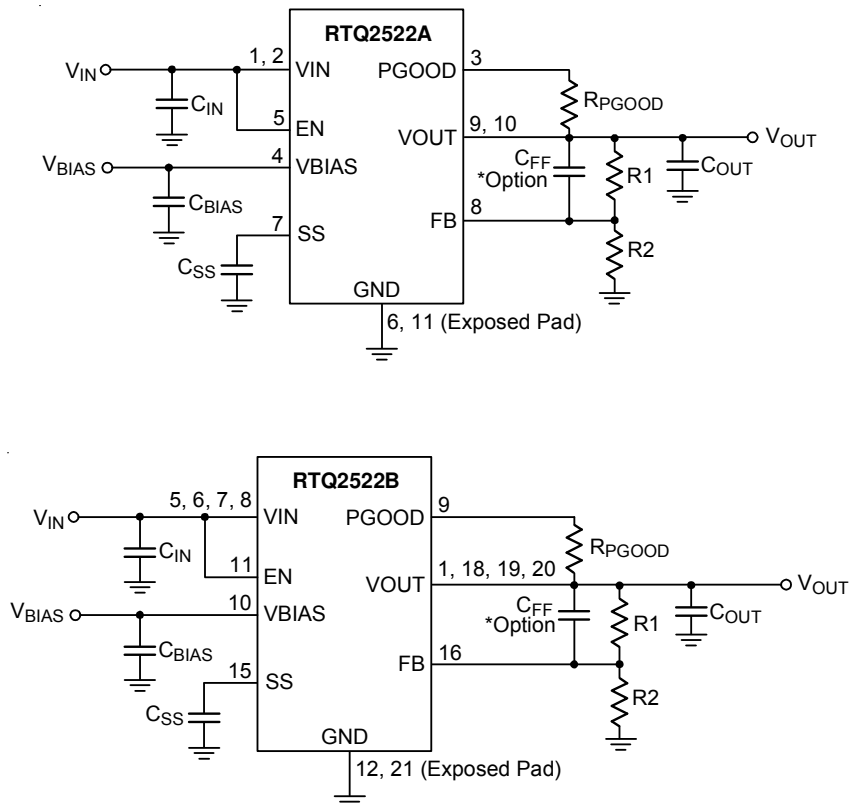

* : The feedforward capacitor is optional for the transient response and circuit stability improvement.

Table 1. Suggested Component Value

V _{OUT} (V)	R1 (kΩ)	R2 (kΩ)
0.8	Short	Open
0.9	0.619	4.99
1.0	1.13	4.53
1.05	1.37	4.42
1.1	1.87	4.99
1.2	2.49	4.99
1.5	4.12	4.75
1.8	3.57	2.87
2.5	3.57	1.69
3.3	3.57	1.15

Typical Operating Characteristics

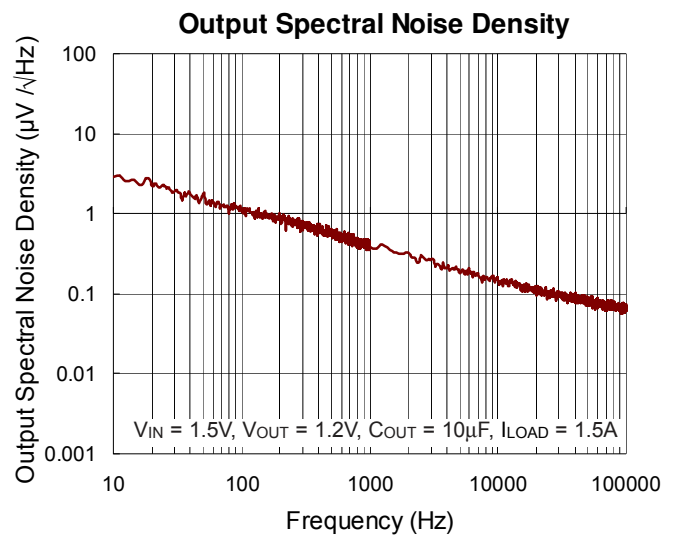
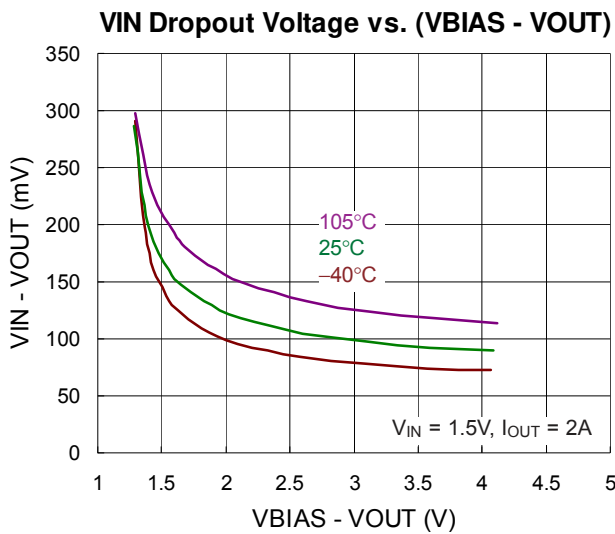
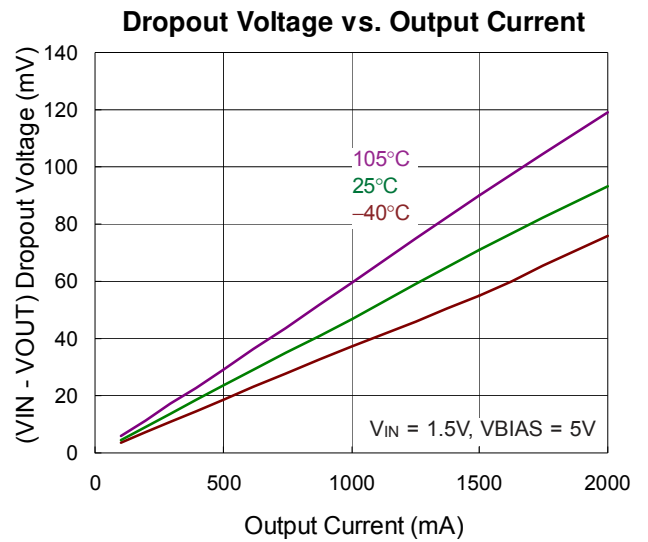
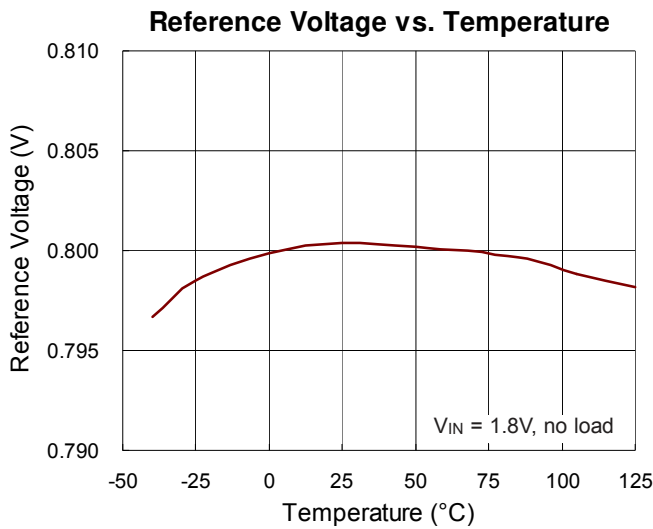
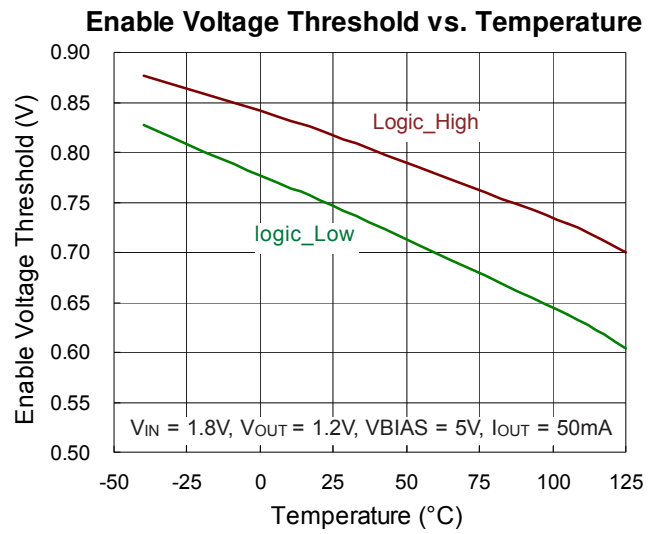
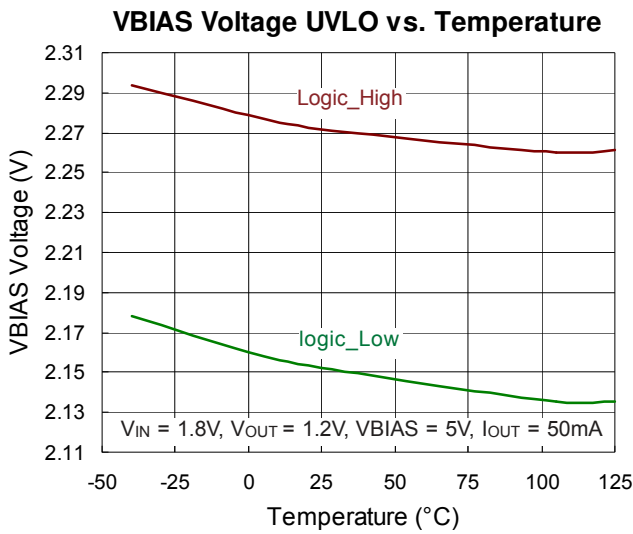

VIN PSRR vs. Frequency

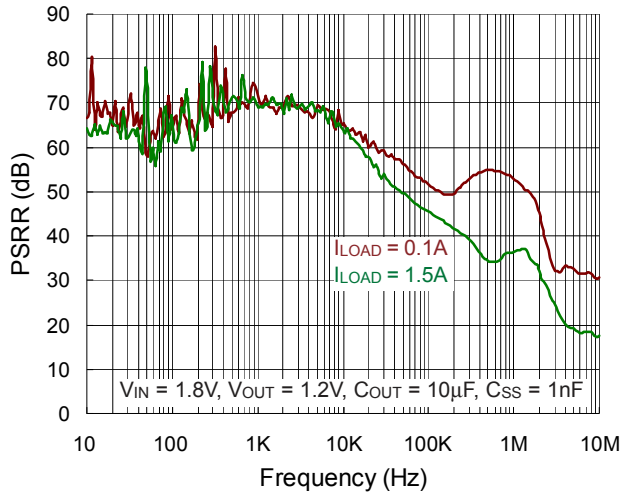

VBIAS PSRR vs. Frequency

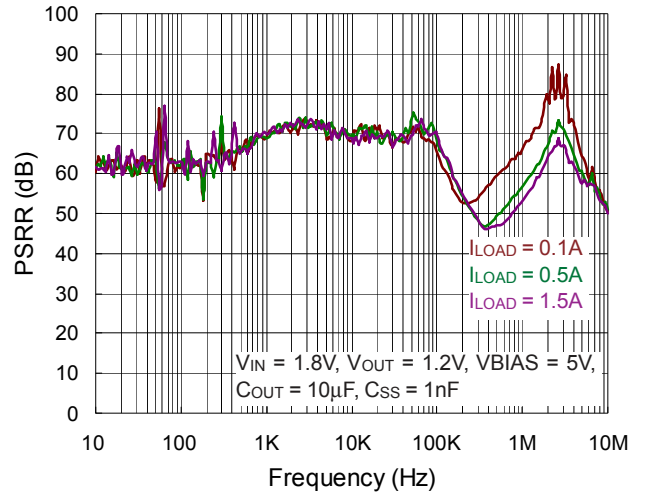

Power Up Response

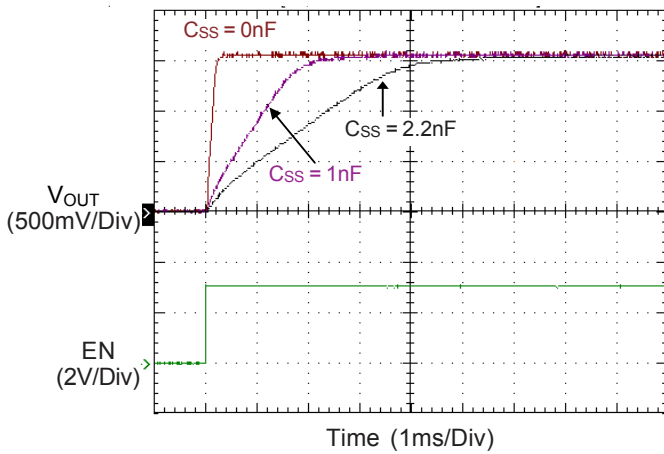

Load Transient Response

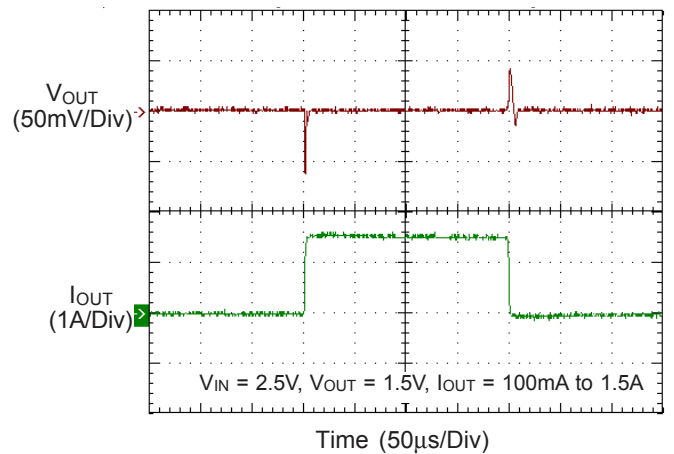

Application Information

Richtek's component specification does not include the following information in the Application Information section. Thereby no warranty is given regarding its validity and accuracy. Customers should take responsibility to verify their own designs and reserve suitable design margin to ensure the functional suitability of their components and systems.

The RTQ2522A/B is a low dropout regulator that features soft-start capability. It provides EN and PGOOD for easily system sequence control, and built-in over current & thermal protection for safe operation.

Dropout Voltage

Because of two power supply inputs VIN and VBIAS and one VOUT regulator output, there are two Dropout voltages specified. The first is the VIN Dropout voltage is the voltage difference (VIN – VOUT) when VOUT starts to decrease by percent specified in the Electrical Characteristics table.

The second, VBIAS dropout voltage is the voltage difference (VBIAS – VOUT) when VIN and VBIAS pins are joined together and VOUT starts to decrease. This option allows the device to be used in applications where an auxiliary bias voltage is not available or low dropout is not required. In these applications, VBIAS is suggested be 1.8V above VOUT and attention on power rating and thermal is needed.

Input, Output, and Bias Capacitor Selection

The device is designed to be stable for all available types and values of output capacitors $\geq 2.2\mu\text{F}$. The device is also stable with multiple capacitors in parallel, which can be of any type or value. The capacitance required on the VIN and VBIAS pins strongly depends on the input supply source impedance. To counteract any inductance in the input, the minimum recommended capacitor for VIN is $1\mu\text{F}$ and minimum recommended capacitor for VBIAS is $0.1\mu\text{F}$. If VIN and VBIAS are connected to the same supply, the recommended minimum capacitor for VBIAS is $4.7\mu\text{F}$. Good quality, low ESR capacitors should be used on the input; ceramic X5R and X7R capacitors are preferred. These capacitors should be placed as close the pins as possible for optimum performance.

Adjusting the Output Voltage

The output voltage of the RTQ2522A/B is adjustable from 0.8V to 3.6V by external voltage divider resistors as shown

in Typical Application Circuit. R1 and R2 can be calculated the output voltage. In order to achieve the maximum accuracy specifications, R2 should be $\leq 4.99\text{k}\Omega$.

Power Up Sequence Requirement

The RTQ2522A/B supports power on the input VIN, VBIAS, and EN pins in any order without damage the device. Generally, connecting the EN and VIN for most application is acceptable, as long as VIN and VEN is greater than the EN threshold (typ. = 1.1V) and the input ramp rate of VIN and VBIAS is faster than the output settled soft-start ramp rate. If the VIN/BIAS input source ramp rate is slower than the output settled soft-start time, the output will track the input supply ramp up level and minus the dropout voltage until it reaches the settled output voltage level. For the other case, If EN is connected with VBIAS, and the provided VIN is present before VBIAS, the output soft-start will as programmed. While VBIAS and VEN are present before VIN is applied also the settled soft-start time has expired, then VOUT tracks VIN ramp up. If the soft-start time has not expired, output tracks VIN ramp up until output reaches the value set by the charging soft-start capacitor.

Thermal Considerations

The junction temperature should never exceed the absolute maximum junction temperature $T_{J(\text{MAX})}$, listed under Absolute Maximum Ratings, to avoid permanent damage to the device. The maximum allowable power dissipation depends on the thermal resistance of the IC package, the PCB layout, the rate of surrounding airflow, and the difference between the junction and ambient temperatures. The maximum power dissipation can be calculated using the following formula :

$$P_{D(\text{MAX})} = (T_{J(\text{MAX})} - T_A) / \theta_{JA}$$

where $T_{J(\text{MAX})}$ is the maximum junction temperature, T_A is the ambient temperature, and θ_{JA} is the junction-to-ambient thermal resistance.

For continuous operation, the maximum operating junction temperature indicated under Recommended Operating Conditions is 125°C. The junction-to-ambient thermal resistance, θ_{JA} , is highly package dependent. For a WDFN-10L 3x3 package, the thermal resistance, θ_{JA} , is 30.5°C/W on a standard JEDEC 51-7 high effective-thermal-conductivity four-layer test board. For a WQFN-20L 5x5 package, the thermal resistance, θ_{JA} , is 28.2°C/W on a standard JEDEC 51-7 high effective-thermal-conductivity four-layer test board. The maximum power dissipation at $T_A = 25^\circ\text{C}$ can be calculated as below :

$$P_{D(\text{MAX})} = (125^\circ\text{C} - 25^\circ\text{C}) / (30.5^\circ\text{C/W}) = 3.27\text{W for a WDFN-10L 3x3 package.}$$

$$P_{D(\text{MAX})} = (125^\circ\text{C} - 25^\circ\text{C}) / (28.2^\circ\text{C/W}) = 3.54\text{W for a WQFN-20L 5x5 package.}$$

The maximum power dissipation depends on the operating ambient temperature for the fixed $T_{J(\text{MAX})}$ and the thermal resistance, θ_{JA} . The derating curves in Figure 1 allows the designer to see the effect of rising ambient temperature on the maximum power dissipation.

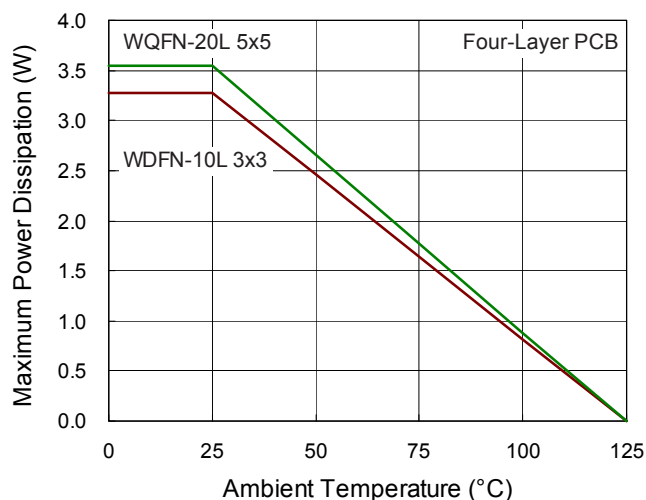

Figure 1. Derating Curve of Maximum Power Dissipation

Layout Considerations

For best performance of the RTQ2522A/B, the PCB layout suggestions below are highly recommend :

- ▶ Input capacitor must be placed as close as possible to IC to minimize the power loop area.
- ▶ Minimize the power trace length and avoid using vias for the input and output capacitors connection.

Figure 2 and Figure 3 shows the examples for the layout reference which helps the inductive parasitic components minimization, load transient reduction and good circuit stability.

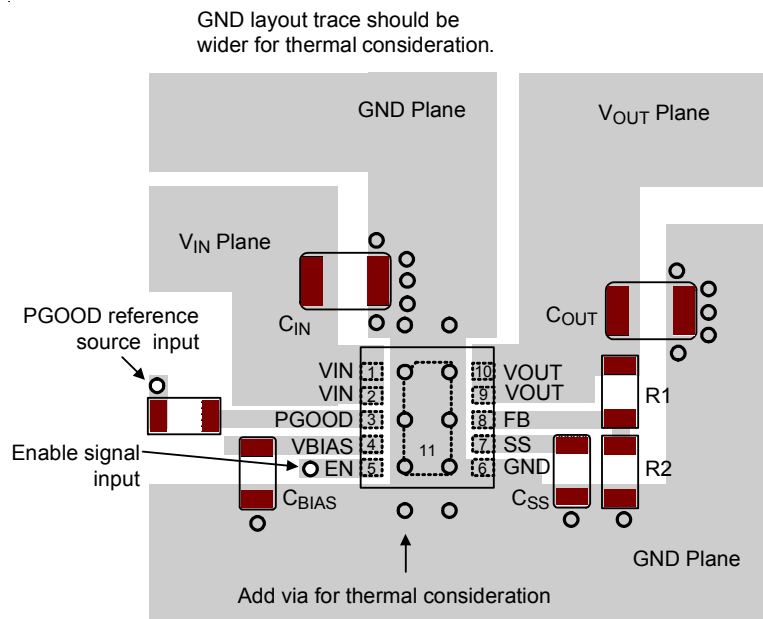

Figure 2. RTQ2522A PCB Layout Guide

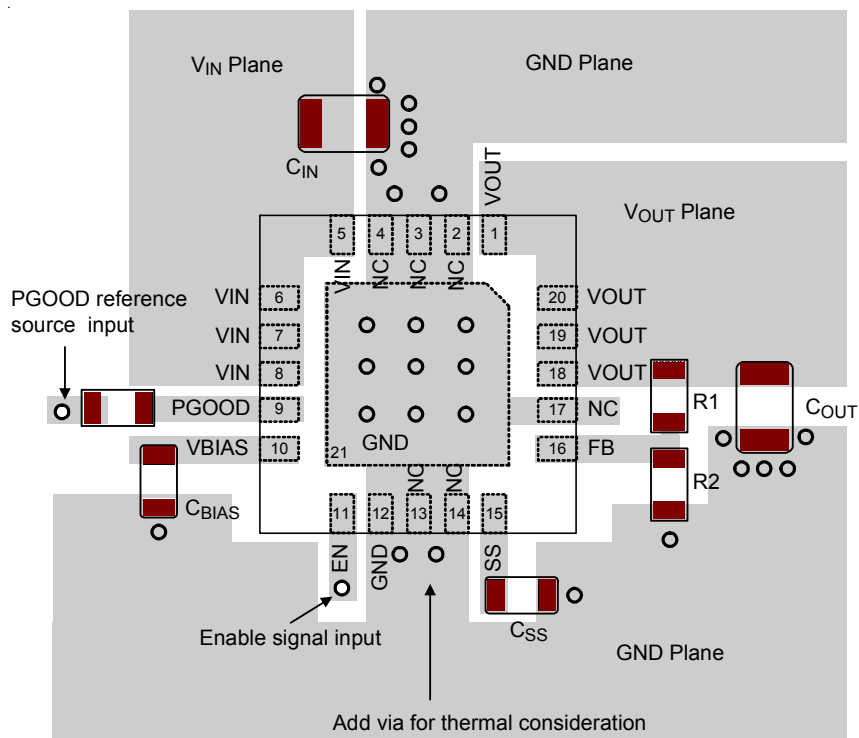
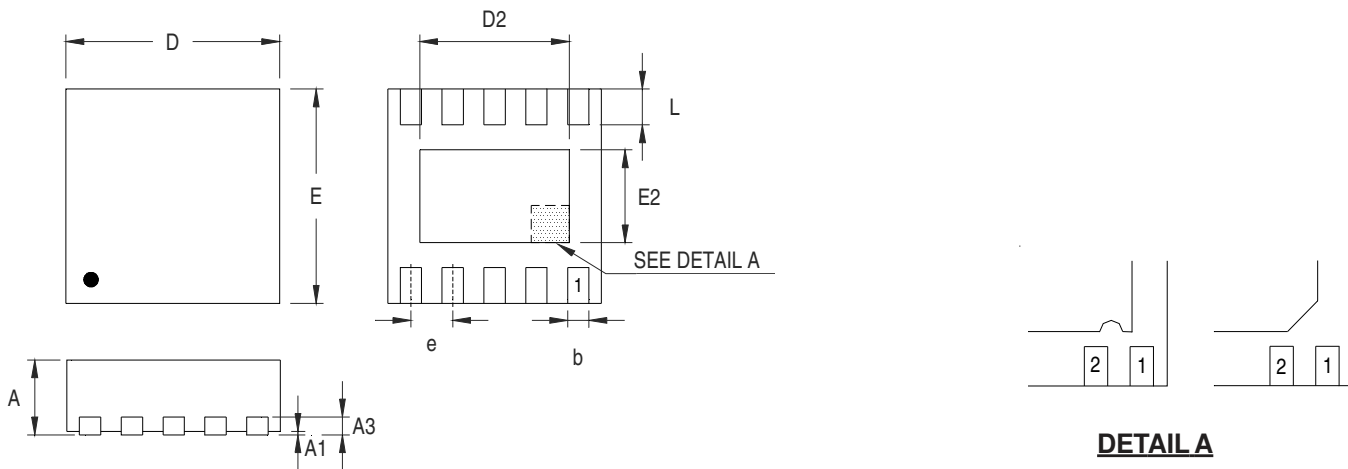

Figure 3. RTQ2522B PCB Layout Guide

Outline Dimension



DETAIL A

Pin #1 ID and Tie Bar Mark Options

Note : The configuration of the Pin #1 identifier is optional, but must be located within the zone indicated.

Symbol	Dimensions In Millimeters		Dimensions In Inches	
	Min	Max	Min	Max
A	0.700	0.800	0.028	0.031
A1	0.000	0.050	0.000	0.002
A3	0.175	0.250	0.007	0.010
b	0.180	0.300	0.007	0.012
D	2.950	3.050	0.116	0.120
D2	2.300	2.650	0.091	0.104
E	2.950	3.050	0.116	0.120
E2	1.500	1.750	0.059	0.069
e	0.500		0.020	
L	0.350	0.450	0.014	0.018

W-Type 10L DFN 3x3 Package

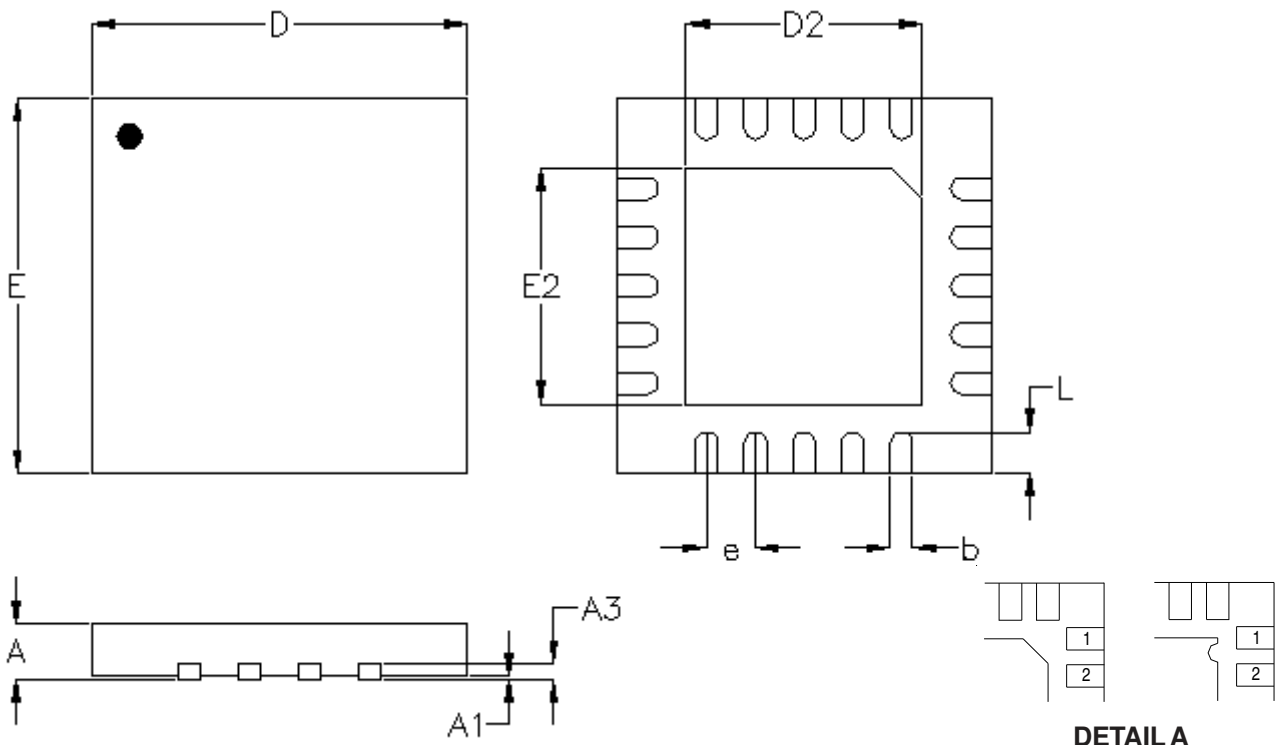

DETAILA

Pin #1 ID and Tie Bar Mark Options

Note : The configuration of the Pin #1 identifier is optional, but must be located within the zone indicated.

Symbol	Dimensions In Millimeters		Dimensions In Inches	
	Min.	Max.	Min.	Max.
A	0.700	0.800	0.028	0.031
A1	0.000	0.050	0.000	0.002
A3	0.175	0.250	0.007	0.010
b	0.250	0.350	0.010	0.014
D	4.900	5.100	0.193	0.201
D2	3.100	3.200	0.122	0.126
E	4.900	5.100	0.193	0.201
E2	3.100	3.200	0.122	0.126
e	0.650		0.026	
L	0.500	0.600	0.020	0.024

W-Type 20L QFN 5x5 Package

Footprint Information

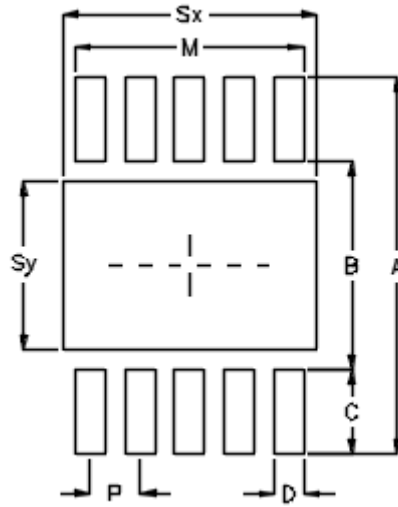

Package	Number of Pin	Footprint Dimension (mm)								Tolerance
		P	A	B	C	D	Sx	Sy	M	
V/W/U/X/ZDFN3*3-10	10	0.50	3.80	2.10	0.85	0.30	2.55	1.70	2.30	±0.05

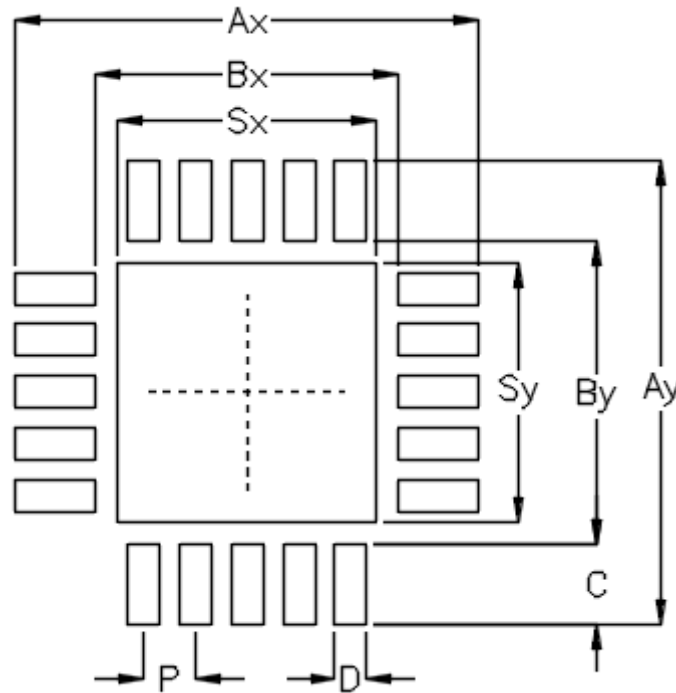

Package	Number of Pin	Footprint Dimension (mm)								Tolerance	
		P	Ax	Ay	Bx	By	C	D	Sx		Sy
V/W/U/XQFN5*5-20	20	0.65	5.80	5.80	3.80	3.80	1.00	0.40	3.25	3.25	±0.05

Richtek Technology Corporation

14F, No. 8, Tai Yuen 1st Street, Chupei City
 Hsinchu, Taiwan, R.O.C.
 Tel: (8863)5526789



Richtek products are sold by description only. Customers should obtain the latest relevant information and data sheets before placing orders and should verify that such information is current and complete. Richtek cannot assume responsibility for use of any circuitry other than circuitry entirely embodied in a Richtek product. Information furnished by Richtek is believed to be accurate and reliable. However, no responsibility is assumed by Richtek or its subsidiaries for its use; nor for any infringements of patents or other rights of third parties which may result from its use. No license is granted by implication or otherwise under any patent or patent rights of Richtek or its subsidiaries.

Datasheet Revision History

Version	Date	Description	Item
04	2023/8/7	Modify	General Description on P1 Features on P1 Ordering Information on P1 Operation on P3 Electrical Characteristics on P5 Application Information on P10