

PRODUCT DATA DRAWING

REVISION HISTORY			
REV	DESCRIPTION	DATE	APPROVED
-	REL. NRN 41623	06/06/17	STW

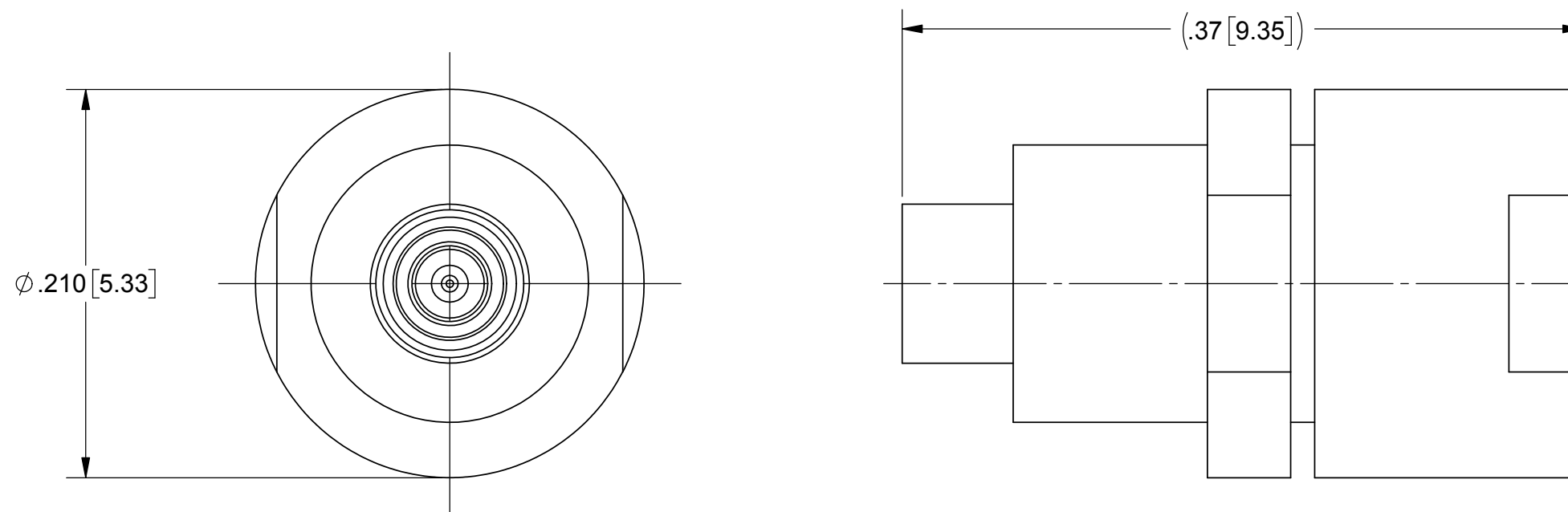

- MATERIAL:**
- BODY &** STAINLESS STEEL PER AMS 5640, UNS ALLOY S30300, TYPE 1 OR ASTM A582, TYPE 303, CONDITION A.
- CONTACT & SLEEVES:** BERYLLIUM COPPER PER ASTM B196, ALLOY No. UNS C17300, TD04.
- INSULATOR:** POLYETHERIMIDE (ULTEM 1000)PER ASTM D5205.
- RESISTOR ELEMENT:** ALUMINUM NITRIDE SUBSTRATE WITH TANTALUM NITRIDE RESISTOR WITH GOLD PALTED TERMINALS.
- BELLOWS SPRING:** ELECTRO-DEPOSITED NICKEL, GOLD PLATED.
- FINISH:**
- BODY & CAP:** PASSIVATED PER AMS 2700.
- CONTACT & SLEEVES:** GOLD PER ASTM B488, TYPE II, CODE C, CLASS 1.27, OVER NICKEL PER AMS-QQ-N-290, CLASS 1, .00005" MIN.
- PERFORMANCE:**
- IMPEDANCE:** 50 OHMS
- FREQ. RANGE:** DC TO 40.0 GHz
- VSWR:** 1.30:1 DC TO 40.0 GHz

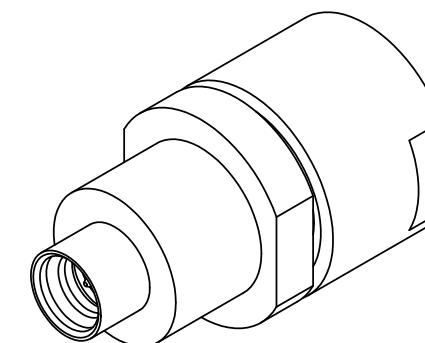

MATERIAL: SEE NOTES	DIMENSIONS ARE IN INCHES TOLERANCES: FRACTIONAL: ±1/64 ANGULAR: X° ±1'0" X°X' ±15'	UNLESS OTHERWISE SPECIFIED 1) ALL DIMENSIONS ARE IN INCHES (MILLIMETERS) 2) ALL DIMENSIONS ARE AFTER PLATING. 3) BREAK CORNERS & EDGES .005 R. MAX. 4) CHAM. 1ST & LAST THREADS. 5) SURFACE ROUGHNESS 63-MIL-STD-10. 6) DIA. 'S ON COMMON CENTERS TO BE CONCENTRIC WITHIN .005 T.I.R. 7) REMOVE ALL BURRS	SV Microwave, Inc. 2400 Centrepark West Drive, Suite 100 West Palm Beach, FL 33409	
FINISH: SEE NOTES	DECIMAL: X ±.030 .XX ±.010 .XXX ±.005		TITLE: SMPS MALE F.D. 1/2W TERMINATION	
SURFACE AREA: N/A	INTERPRET DIMENSIONS AND TOLERANCES PER ASME Y14.5M - 1994	DRAWN: JMC 06/06/17	SIZE: B	CAGE CODE: 95077
PROPRIETARY THE INFORMATION CONTAINED IN THIS DRAWING IS THE SOLE PROPERTY OF SV MICROWAVE, INC. ANY REPRODUCTION IN PART OR AS A WHOLE WITHOUT THE WRITTEN PERMISSION OF SV MICROWAVE, INC IS PROHIBITED.	THIRD ANGLE PROJECTION 	CHECKED: STW 06/06/17	DWG. NO. SF8038-6007	SCALE: 12:1
		APPROVED: STW 06/06/17		SHEET 1 OF 1