

Part No.	X = Body Length
PLP2-100-D	0.100 (2.5mm)
PLP2-125-D	0.125 (3.2mm)
PLP2-2.5MM-D	2.5mm (0.100")
PLP2-3MM-D	3mm (0.118")

REV.	DESCRIPTION	DATE	APPROVED
A	Engineering Release	07/15/15	J. C.

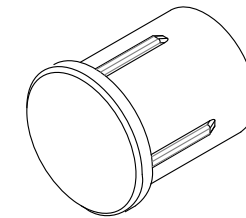
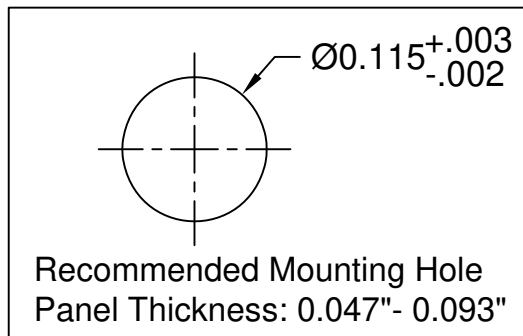
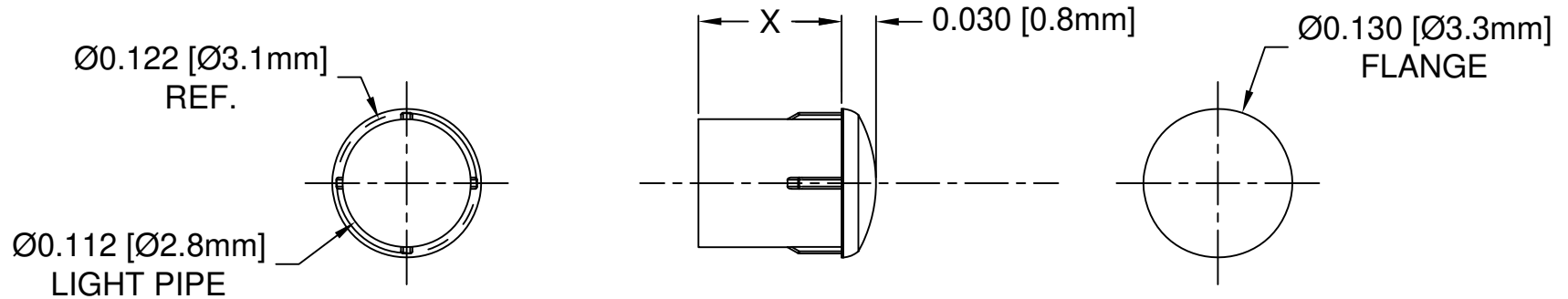

2. MATERIAL: POLYCARBONATE, 94V-0, WHITE DIFFUSED.
1. GENERAL SPECIFICATIONS: BIVAR MOLDED COMPONENT SPECIFICATION BV00-E101 and BSMC-1001.

STANDARD TOLERANCE (UNLESS OTHERWISE SPECIFIED)		BIVAR [®]	
DECIMALS	ANGULAR	4 THOMAS, IRVINE, CA. 92618	
.X ± .1	X° ± 1°	TEL: (949) 951-8808 FAX: (949) 951-3974	
.XX ± .01		TITLE: PRESS-FIT, PANEL MOUNT, LIGHT PIPE, FRONT MOUNT, DIFFUSED	
.XXX ± .005		PART NO: PLP2-XXX-D	
DESIGNED: Brian Oliver	DATE: 04/02/15	REVISION: A	CAGE CODE : 32559
CHECKED: A. Wright	DATE: 04/02/15	SHEET # 1 OF 1	
CAD GENERATED DOCUMENT. DO NOT MEASURE DRAWING.			