

TPS658640 System Evaluation Board

This user's guide describes the characteristics, operation, and use of the TPS658640EVM-747 evaluation module (EVM). The TPS658640EVM-747 is a fully assembled and tested platform for evaluating the performance of the TPS658640 single-chip, power management device. This document includes schematic diagrams, a printed-circuit board layout, bill of materials, and test data.

Contents

1	Introduction	3
	1.1 Features	3
	1.2 Applications	3
	1.3 Requirements	3
2	Electrical Performance Specifications	3
3	Schematic	4
4	Connector and Test Point Descriptions	8
	4.1 Headers and Switches	8
	4.2 Jumpers	9
5	Setup	10
6	TPS658640EVM Test Data	11
	6.1 Operation Waveforms	11
	6.2 Thermal Performance	14
7	EVM Assembly Drawings and Layout	16
8	Bill of Materials	20

List of Figures

1	HPA747A Schematic, Sheet 1	4
2	HPA747A Schematic, Sheet 2	5
3	HPA747A Schematic, Sheet 3	6
4	HPA747A Schematic, Sheet 4	7
5	SM0, Ch. 1 - VIN 1 V/div; Ch. 2 - SW 1 V/div; Ch. 3 - Vout 10 mV/div	11
6	SM1, Ch. 1 - VIN 1 V/div; Ch. 2 - SW 1 V/div; Ch. 3 - Vout 10 mV/div	11
7	SM2, Ch. 1 - VIN 1 V/div; Ch. 2 - SW 1 V/div; Ch. 3 - Vout 10 mV/div	12
8	SM0, SM1, SM2, and LDO1 Start-Up	12
9	LDO1, LDO2, LDO3, and LDO4 Start-Up	13
10	LDO4, LDO5, and LDO9 Start-Up	13
11	32-kHz Clock	14
12	Thermal Performance – Top Side	15
13	Thermal Performance – Bottom Side	15
14	Top Assembly – Silkscreen	16
15	Top Layer	16
16	Layer 2	17
17	Layer 3	17
18	Layer 4	18
19	Layer 5	18
20	Layer 6	19

21	Bottom Layer	19
----	--------------------	----

List of Tables

1	Headers and Switches	8
2	Jumpers	9
3	Bill of Materials.....	20

1 Introduction

The TPS658640 is a single-chip, power management integrated circuit (IC) with multiple regulated power supplies, system management, and display functions in a small package. The I2C interface enables control of a wide range of subsystem parameters. Internal registers have a complete set of status information, enabling easy diagnostics and host-controlled handling of fault conditions.

1.1 Features

- Three programmable step-down converters
 - Eleven programmable general-purpose LDOs
- Three PWM outputs with programmable frequency and duty cycle
- Dual RGB LED drivers
- Eleven-channel ADC with three operating modes
- External ADC triggering and step-down converter mode control
- Power-Good monitoring on all supply outputs
- Interrupt controller with maskable interrupts

1.2 Applications

- Tablet Portable Computers
 - Netbooks
 - Smart phones
 - Portable navigation devices
 - Portable media players

1.3 Requirements

In order to operate this EVM properly, the hardware must be connected and properly configured. All components and connectors are installed on the EVM as shipped, except the dc power supplies.

2 Electrical Performance Specifications

Input voltage, VIN, 3 V to 5.5 V

Output current, step-down converters, 1.5 A (SMO, SM2) and 2 A (SM1)

Output voltage LDOs, seven with output voltages of 1.25 V to 3.3 V, two with output voltages of 0.725 V to 1.5 V, one always on with output voltage of 1.25 V to 3.3 V, one with output voltage of 1.7 V to 2.475 V.

3 Schematic

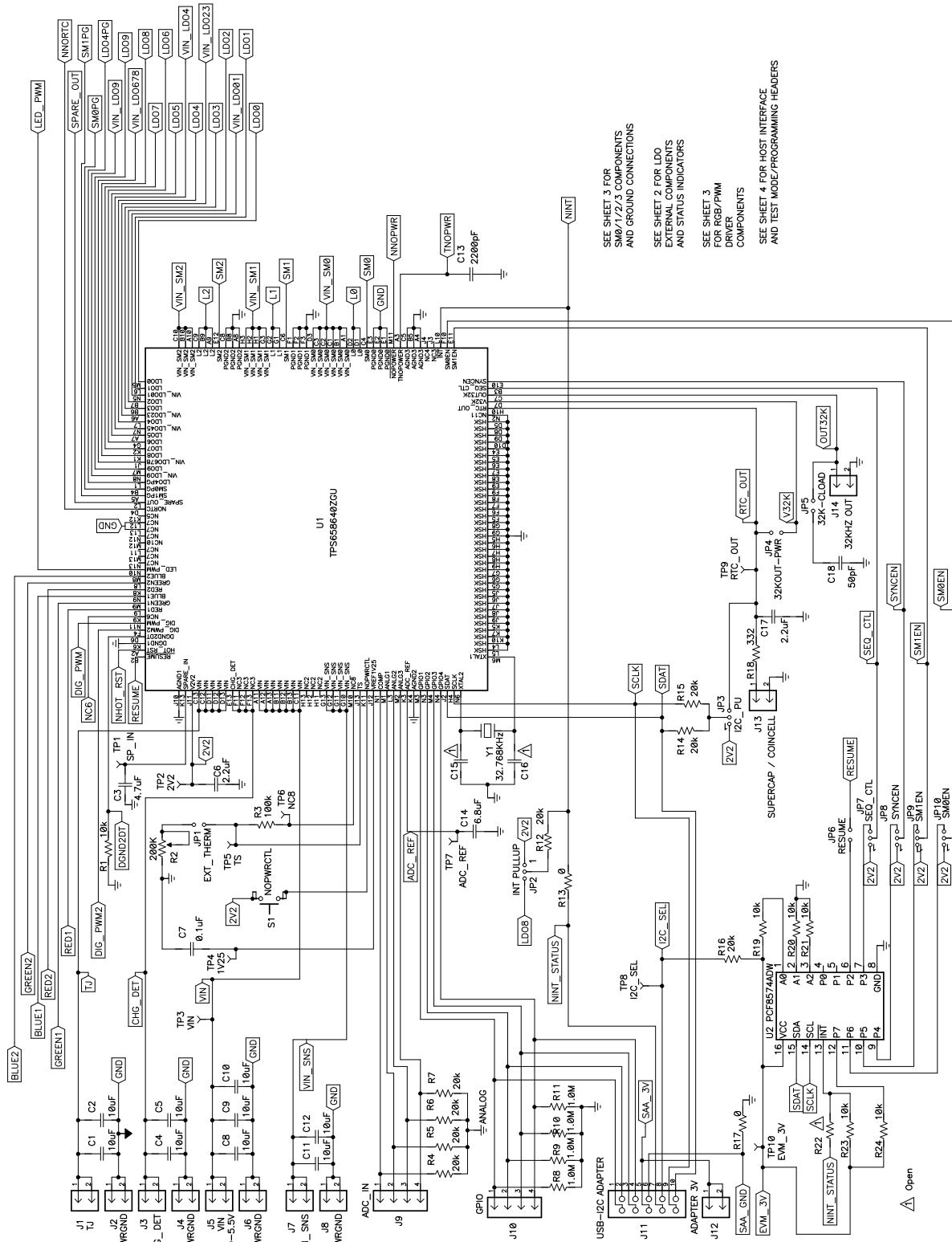

Figure 1. HPA747A Schematic, Sheet 1

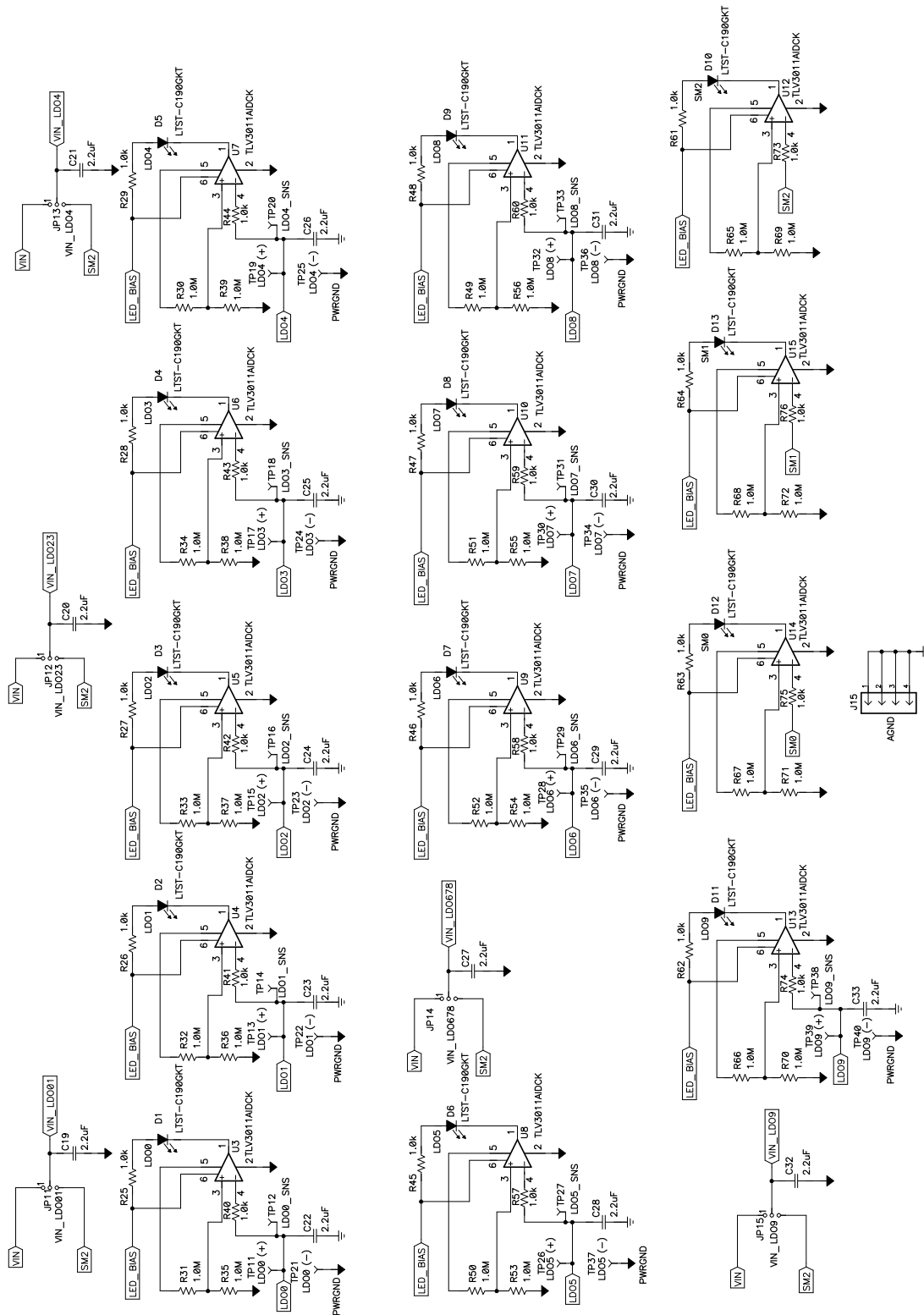

Figure 2. HPA747A Schematic, Sheet 2

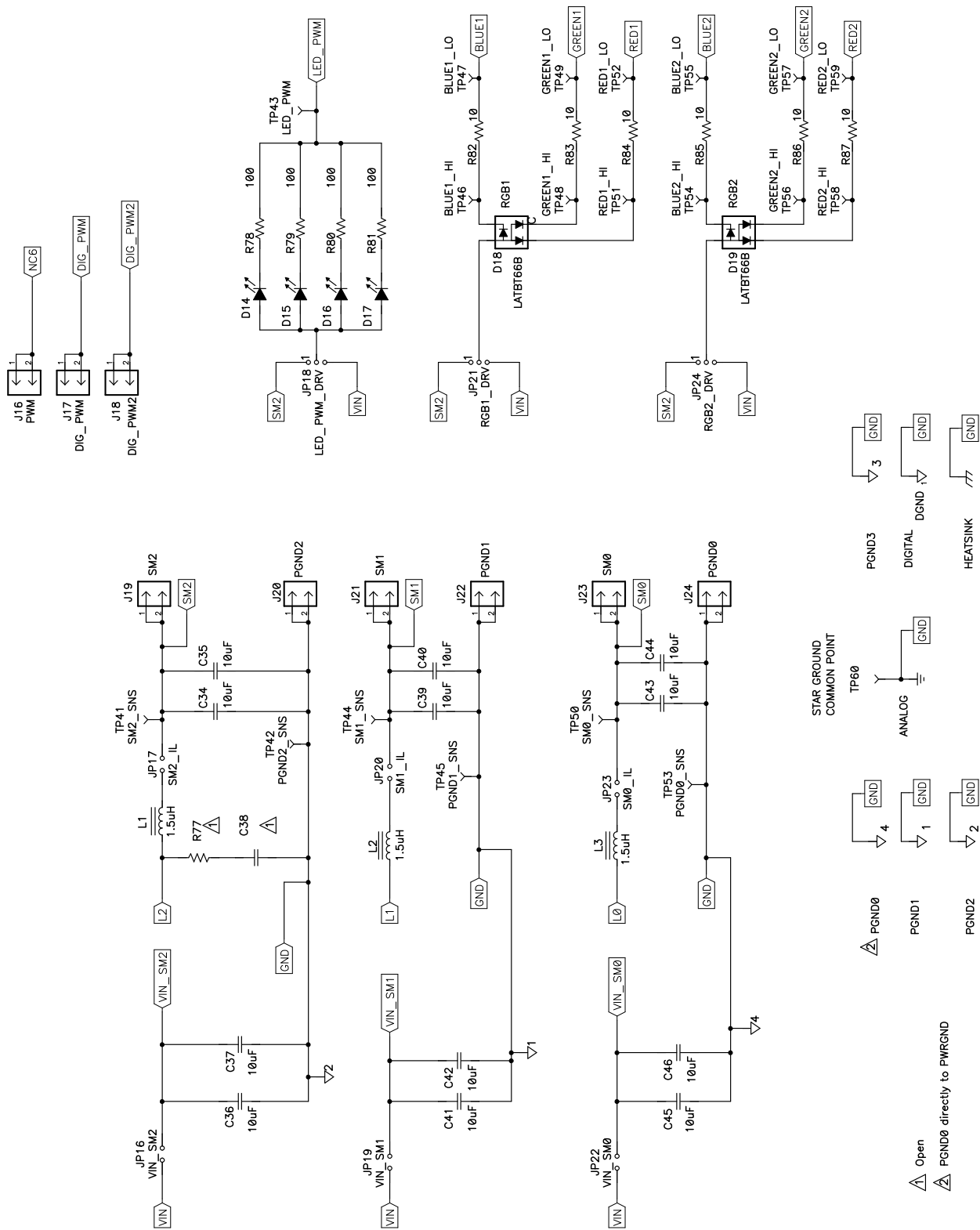

Figure 3. HPA747A Schematic, Sheet 3

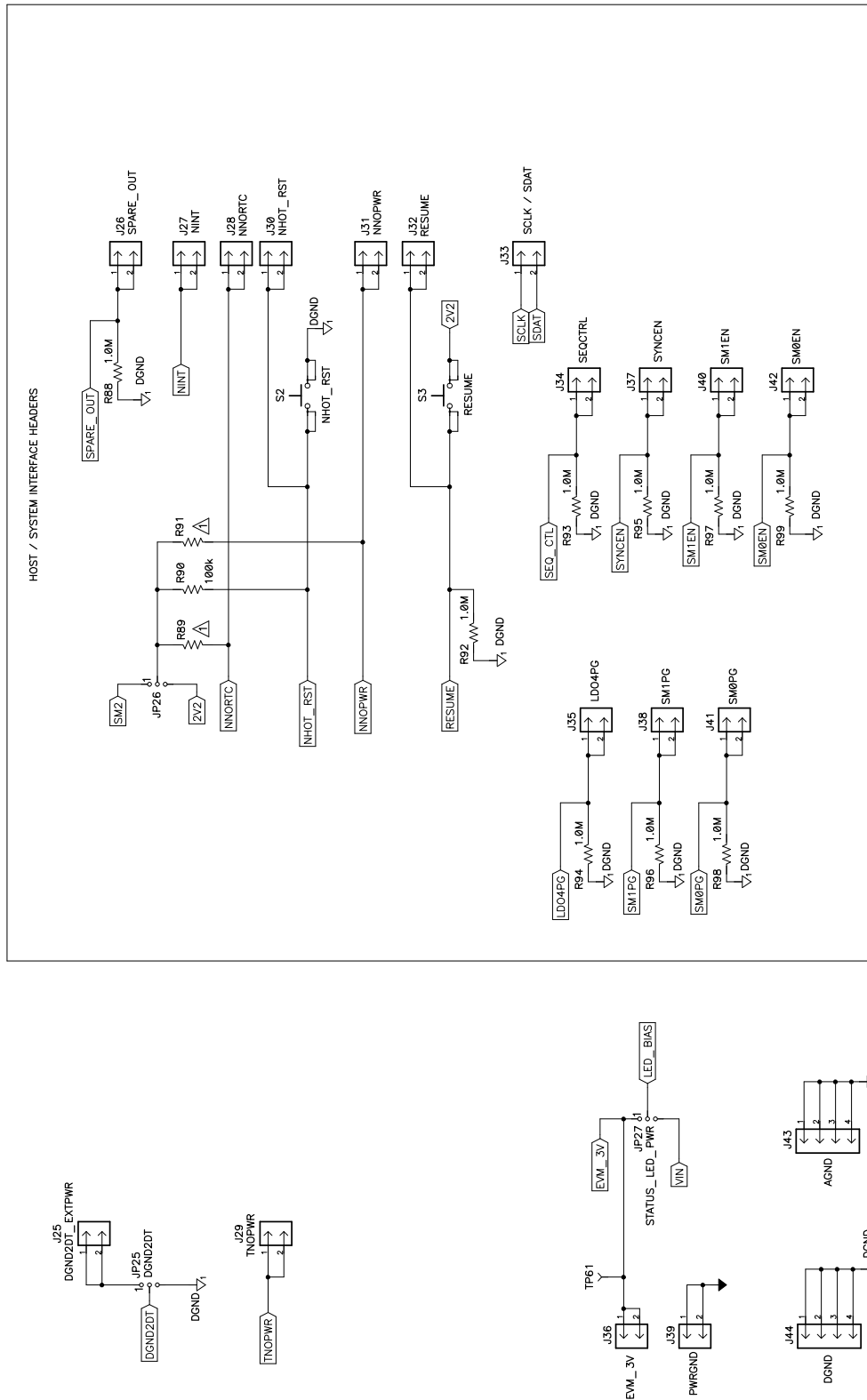

Figure 4. HPA747A Schematic, Sheet 4

4 Connector and Test Point Descriptions

4.1 Headers and Switches

The following table contains header and switch descriptions.

Table 1. Headers and Switches

Header/Switch	Title	Description
J1	TJ	Test jumper, connected to VIN pins C12 and C13 and D11-D13
J2	PWRGND	Power ground, connected to ground plane
J3	CHG_DET	Charger Detection Input, connected to CHG_DET (pin E13) and NC3 (pins F11 - F13)
J4	PWRGND	Power ground, connected to ground plane
J5	VIN	Power supply input; connect BAT or ac adapter here to J5; connected to pins A11 - A13, B11 - B13, and C11
J6	PWRGND	Power ground, connected to ground plane
J7	VIN_SNS	Header to sense voltage at VIN; do not use as current path or Kelvin sense; connected to pins G10 - G13
J8	PWRGND	Power ground, connected to ground plane
J9	ADC_IN	Pins COMP (pin N1, input comparator for autoboot feature) and ALNG1 - ALNG3 (pins L3, M1, M2) - inputs to analog-to-digital converter. 20-kΩ pulldown to AGND
J10	GPIO	Connected to pins GPIO1 - GPIO4 (M3, M4, N3, N4) with 1-MΩ pulldown to AGND
J11	USB-I2C ADAPTER	Connection for USB-TO-GPIO TI tool which connects HPA747 board to PC for GUI. Connected to pins GPIO1 - GPIO4 with 1-MΩ pulldown to AGND, SAA_3V, SAA_GND, enable for I2C port expander U2, SCLK, and SDAT
J12	ADAPTER 3V	Header to sense/supply voltage to I2C bus
J13	SUPERCAP/COINCELL	Header to connect external real-time clock (RTC) supply
J14	32KHZOUT	Header to probe pin OUT32K (C7, pin 1 of J14 is OUT32k and pin 2 of J14 is analog ground)
J15	AGND	Header with four connections to analog ground to facilitate oscilloscope ground probe connection
J16	PWM	Header to pin K9; this pin is a no-connect inside the IC (NC6)
J17	DIG_PWM	Header to PWM, digital push-pull output; pin DIG_PWM (N11) on the IC
J18	DIG_PWM2	Header to PWM, digital push-pull output; pin DIG_PWM2 (F4) on the IC
J19	SM2	Output of dc/dc converter SM2
J20	PGND2	Power ground 2 for dc/dc converter SM2
J21	SM1	Output of dc/dc converter SM1
J22	PGND1	Power ground 1 for dc/dc converter SM1
J23	SM0	Output of dc/dc converter SM0
J24	PGND0	Power ground 1 for dc/dc converter SM0
J25	DGND2DT_EXTTPWR	For IT internal use only
J26	SPARE_OUT	No internal connection
J27	NINT	Header for nINT pin; interruption pin nINT is LO when interrupt is requested by TPS65864x. Open-drain output
J28	NNORTC	Header for nNORTC pin (D4); output status pin of RTC_OUT LDO
J29	TNOPWR	Header to monitor NOPOWER pulse width set pin TNOPWR (A3)
J30	NHOT_RST	Header for nHOT_RST pin (A2); reboot cycle request; hardware reboot cycle control, pulled up to JP26 (SM2 or 2V2) through 100 kΩ
J31	NNOPWR	Header for pin nNOPOWER (M11) UP TO OPEN R89 and R91
J32	RESUME	Header for pin RESUME (B2), connected to switch S3, and pulled down to DGND through 1 MΩ

Table 1. Headers and Switches (continued)

Header/Switch	Title	Description
J33	SCLK/SDAT	Header for pins SCLK (H4) pin 1 of header and SDAT (J2) pin 2 of header, for monitoring I2C bus
J34	SEQCTRL	Connected to SEQ_CTL pin (B3), pulled down to DGND through 1M Ω - Discrete input control
J35	LDO4PG	Header for LDO4 Power Good output, pulled down to DGND through 1M Ω
J36	EVM_3V	Header to connect external supply for LED bias and I2C port expander U2
J37	SYNCEN	Header for SYNC enable pulled down to DGND through 1M Ω - Discrete input control
J38	SM1PG	Header for dc/dc converter SM1 Power Good output
J39	PWRGND	Header for ground connection of external supply for LED bias and I2C port expander U2
J40	SM1EN	Header for enabling dc/dc converter SM1 pulled down to DGND through 1M Ω - Discrete input control
J41	SM0PG	Header for dc/dc converter SM0 Power Good output, pulled down to DGND through 1M-Ohm
J42	SM0EN	Header for enabling dc/dc converter SM0 pulled down to DGND through 1 M Ω - Discrete input control
J43	AGND	Header with four connections to analog ground
J44	DGND	Header with four connections to digital ground
S1	NOPWRCTL	Assertion of NOPWRCTL assets nNOPOWER output of PMU, typically used as processor reset without rebooting PMU
S2	NHOT_RST	Used for rebooting PMU
S3	RESUME	Hold to wake up PMU or send PMU to sleep state

4.2 Jumpers

The following table shows the installed jumpers.

Table 2. Jumpers

Jumper	Title	Shunt Location	Description
JP1	EXT_THERM	Installed	Jumper to connect thermistor (R2) to pin TS (J13)
JP2	INT_PULLUP	Between pin 1 and pin 2	Jumper to select pullup voltage for INT pin (L10). Pin 1 and pin 2 shorted INT pulled up to 2V2. If pin 2 and 3 are shorted /INT is pulled up to LDO8
JP3	I2C_PU	Not Installed	Jumper to select pullup voltage for SCLK (H4) and SDAT (J2). Position 1 and position 2 shorted for 2V2 pullup; position 2 and position 3 shorted for pullup to RTC_OUT (H1).
JP4	32KOUT-PWR	Installed	Jumper to connect V32K (D7) to RTC_OUT (H10)
JP5	32K-CLOAD	Not Installed	Jumper to connect 50-pF capacitor to OUT32K (C7)
JP6	RESUME	Not Installed	Jumper to connect RESUME (B2) to pin P2 of the I2C port expander (U2)
JP7	SEQCTRL	Between pin 1 and pin 2	Jumper to connect SEQCTRL (B3) to either 2V2 or pin P3 of the I2C port expander U2
JP8	SYNCEN	Between pin 1 and pin 2	Jumper to connect SYNCEN (E10) to either 2V2 or pin P4 of the I2C port expander U2
JP9	SM1EN	Between pin 1 and pin 2	Jumper to connect SM1EN (E11) to either 2V2 or pin P5 of the I2C port expander U2
JP10	SM0EN	Not Installed	Jumper to connect SM0EN (F10) to either 2V2 or pin P5 of the I2C port expander U2
JP11	VIN_LDO01	Between pin 2 and pin 3	Jumper to select VIN or SM2 as input to LDO0 and LDO1

Table 2. Jumpers (continued)

Jumper	Title	Shunt Location	Description
JP12	VIN_LDO23	Between pin 1 and pin 2	Jumper to select VIN or SM2 as input to LDO2 and LDO3
JP13	VIN_LDO4	Between pin 1 and pin 2	Jumper to select VIN or SM2 as input to LDO4
JP14	VIN_LDO678	Between pin 1 and pin 2	Jumper to select VIN or SM2 as input to LDO6 - LDO8
JP15	VIN_LDO9	Between pin 1 and pin 2	Jumper to select VIN or SM2 as input to LDO9
JP16	VIN_SM2	Installed	Jumper to connect VIN to VIN_SM2
JP17	SM2_IL	Installed	Jumper to measure current through inductor L1
JP18	LED_PWM_DRV	Between pin 2 and pin 3	Jumper to select SM2 or VIN as supply for LEDs, D14 - D17
JP19	VIN_SM1	Installed	Jumper to connects VIN to VIN_SM1
JP20	SM1_IL	Installed	Jumper to measure current through inductor L2
JP21	RGB_DRV	Between pin 2 and pin 3	Jumper to select SM2 or VIN as supply for RGB LED, D18
JP22	VIN_SM0	Installed	Jumper to connects VIN to VIN_SM0
JP23	SM0_IL	Installed	Jumper to measure current through inductor L3
JP24	RGB2_DRV	Between pin 2 and pin 3	Jumper to select SM2 or VIN as supply for RGB LED, D19
JP25	DGND2DT	Between pin 2 and pin 3	For TI internal use only
JP26	JP26	Between pin 2 and pin 3	Jumper to select SM2 or 2V2 as pullup for HOT_RST
JP27	STATUS_LED_PWR	Between pin 1 and pin 2	Jumper to select VIN or EVM_3V J36 as bias for status LEDs, D1 - D13

5 Setup

The following steps are intended to help users power up and evaluate the EVM.

- To use the TPS650864xEVM with a personal computer, the TPS868640xEVM software is required along with the HPA172 USB-to-I2C Interface Board (USB-TO-GPIO) and a USB cable. Two power supplies capable of supplying 6 V at 2 A are required.
- To test the HPA747, the computer must have the TPS65864xEVM software program installed. Install the program from the TPS65864xEVM software zip file. This software zip file is supplied by Texas Instruments. If the program does not automatically install properly, follow the instructions in the Readme file.
- Connect the USB cable between the computer and the HPA172. Connect the Molex cable between the HPA172 and the HPA747 EVM (J11).
- Install the shorting jumpers as noted in the shorting jumper table.
- Supply 1:** Set the input supply voltage to 3.3 V before connecting to the EVM, and turn the supply off. While in the off state, connect the power supply positive lead to J36 (EVM 3V). Connect the power supply return lead to J39 (GND).
- Input Supply 2:** Set the input supply voltage to 5 V before connecting to the EVM, and turn the supply off. While in the off state, connect the power supply positive lead to J5 (VIN). Connect the power supply return lead to J6 (GND).
- First, turn on Input Supply 2 (3.3 V). Next, turn on Input Supply 1 (5 V).
- To wake the PMU, hold the pushbutton switch, S1, RESUME, for one seconds and release. While the PMU is awake, holding switch S1 for one second puts the PMU back into the sleep state. By default, some of the LDOs and switching converters turn on.
- Using the GUI, select the *LDOs* tab on the left side. Press *Read* to load the contents of the I2C registers into the GUI. Next, check all the unchecked boxes. This enables all the LDOs.

10. Using the GUI, select the SMs tab on the left side. Press *Read* to load the contents of the I2C registers into the GUI. Next, check all the unchecked boxes. This enables all the SM converters.

6 TPS658640EVM Test Data

This section presents typical performance data for the TPS658640EVM. Actual performance data can be affected by measurement techniques and environmental variables; therefore, these results are presented for reference and may differ from actual results obtained by some users.

6.1 Operation Waveforms

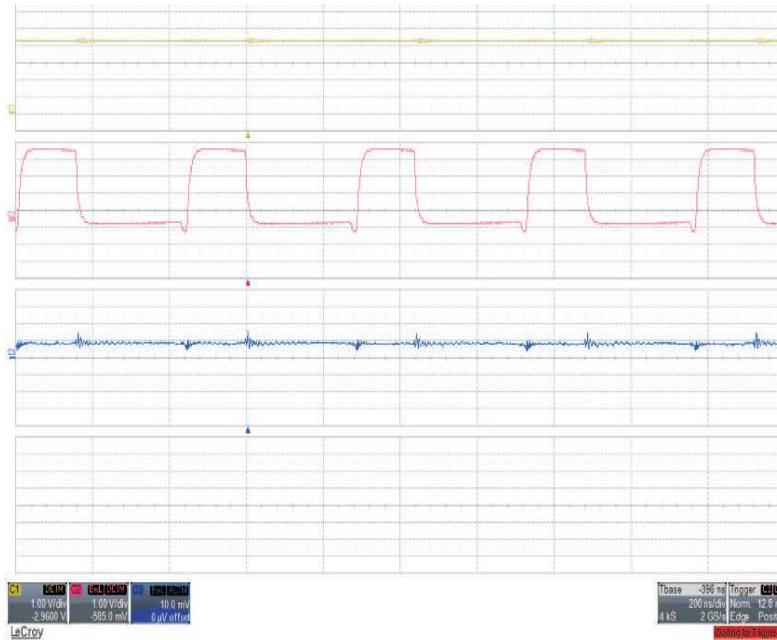

Figure 5. SM0, Ch. 1 - VIN 1 V/div; Ch. 2 - SW 1 V/div; Ch. 3 - Vout 10 mV/div

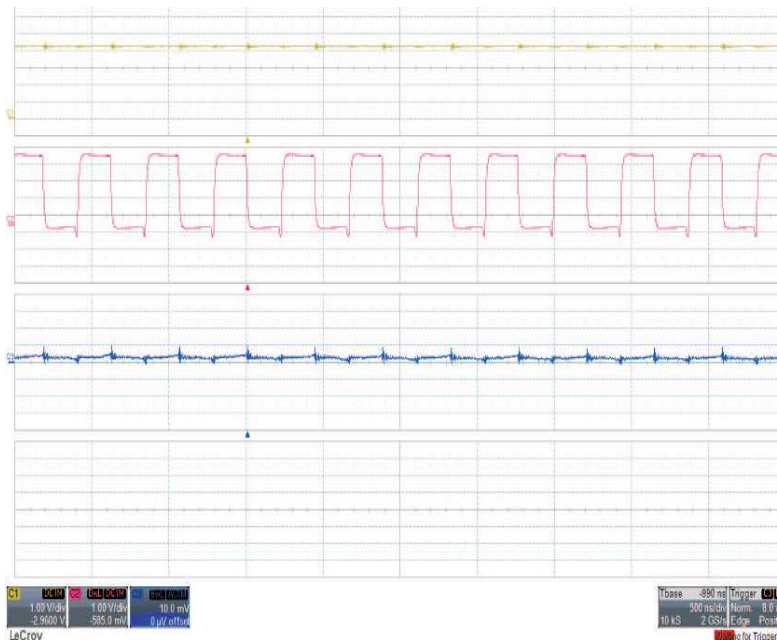

Figure 6. SM1, Ch. 1 - VIN 1 V/div; Ch. 2 - SW 1 V/div; Ch. 3 - Vout 10 mV/div

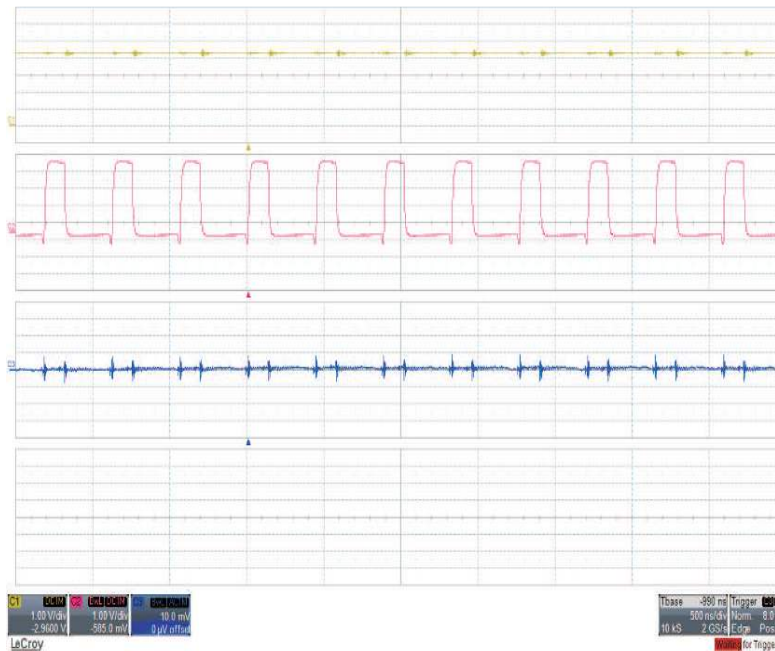

Figure 7. SM2, Ch. 1 - VIN 1 V/div; Ch. 2 - SW 1 V/div; Ch. 3 - Vout 10 mV/div

14-Oct-11
16:15:07

TRIGGER SETUP

1
.5 ms
2.00 V

2
.5 ms
2.00 V

3
.5 ms
5.0 V

4
.5 ms
2.00 V

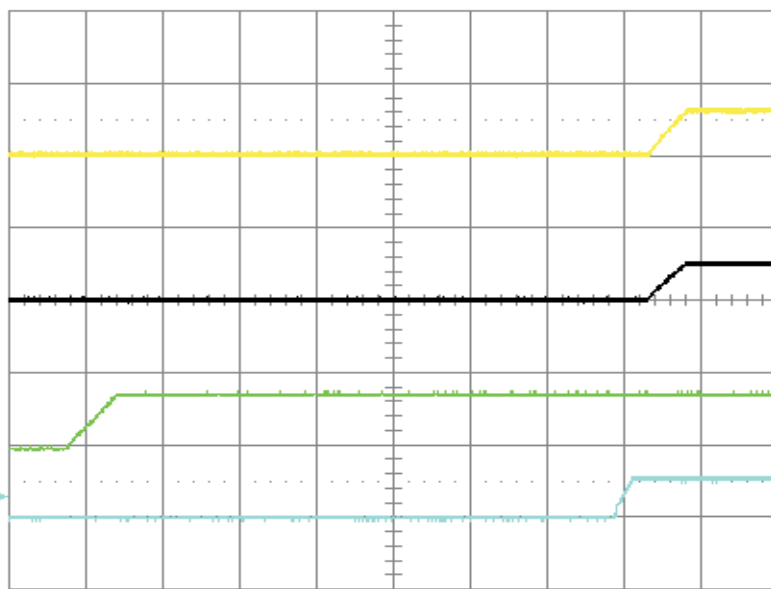

Edge SMART

trigger on
1 2 3 4 Ext
Ext10 Line

coupling 4
DC AC
LFREJ HFREJ

slope 4
Pos Neg
Window

holdoff
- - -
OFF Time Evts

	.5 ms	BWL
1	.2 V	DC $\times 10$
2	.2 V	DC $\times 10$
3	.5 V	DC $\times 10$
4	.2 V	DC $\times 10$

4 DC 0.60 V

20 MS/s

STOPPED

Figure 8. SM0, SM1, SM2, and LDO1 Start-Up

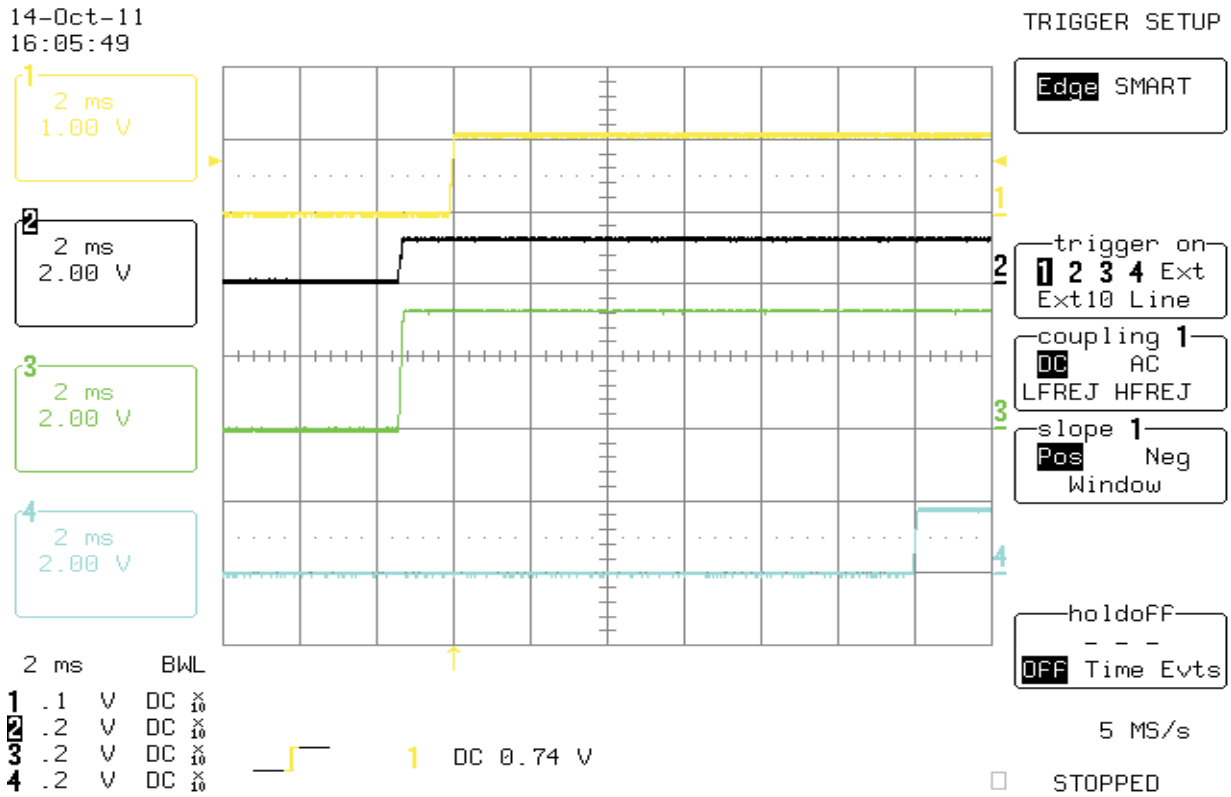

Figure 9. LDO1, LDO2, LDO3, and LDO4 Start-Up

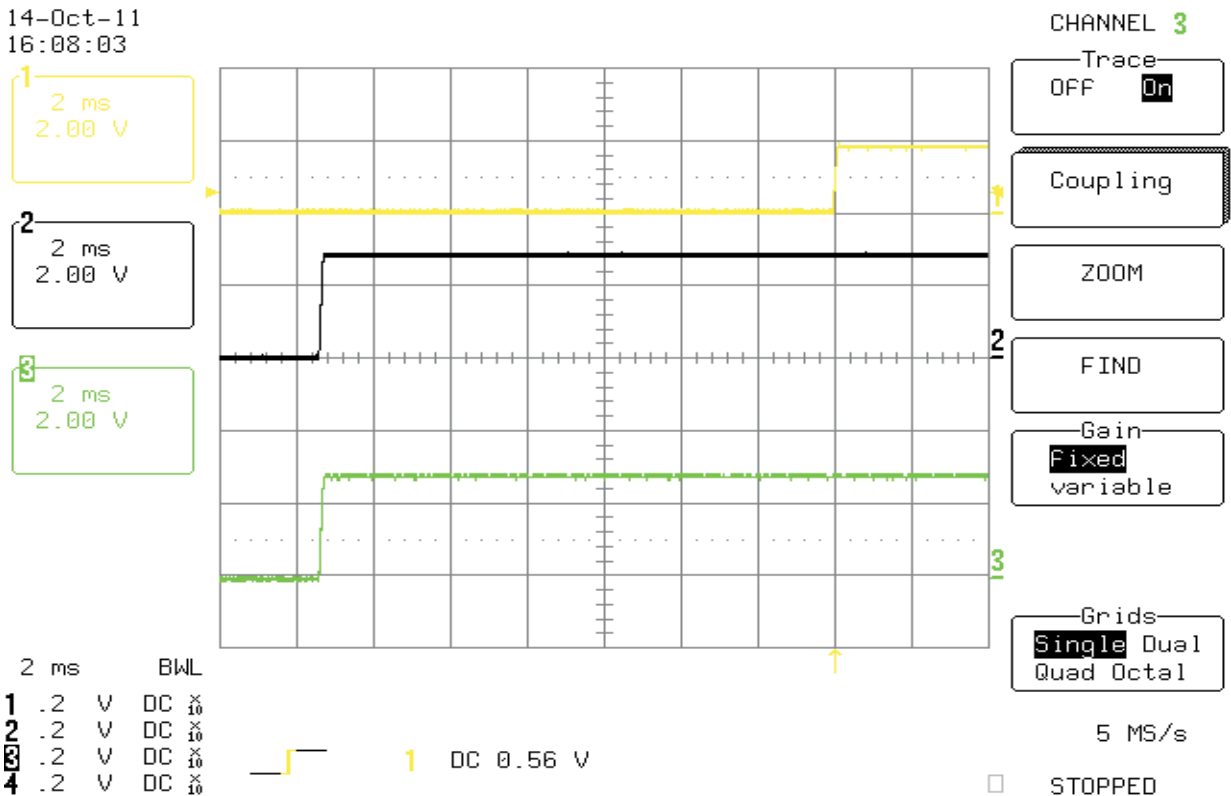
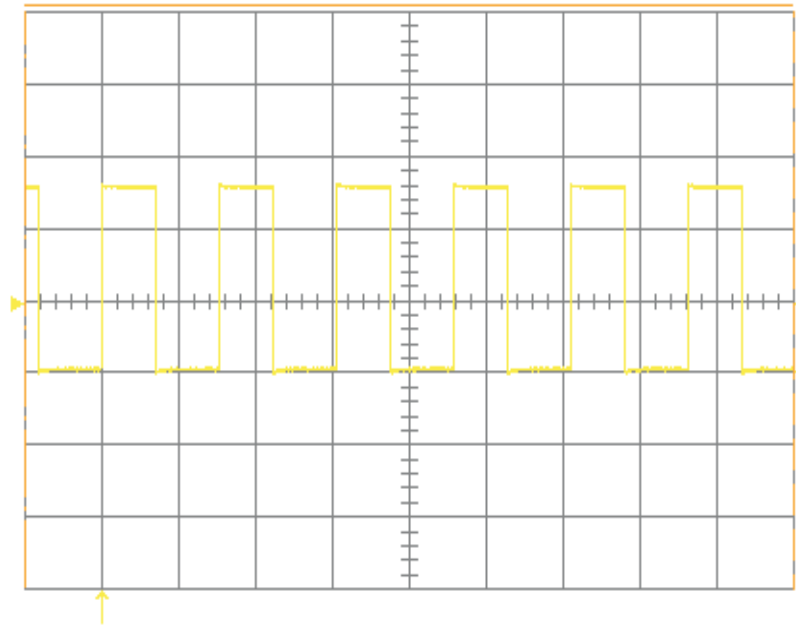

Figure 10. LDO4, LDO5, and LDO9 Start-Up

14-Oct-11
15:51:25

Reading Floppy Disk Drive

20 μ s
1.00 V



Freq(1) 32.7713 kHz

20 μ s BWL

- 1 .1 V DC $\times \frac{10}{10}$
- 2 .2 V DC $\times \frac{10}{10}$
- 3 .2 V DC $\times \frac{10}{10}$
- 4 .2 V DC $\times \frac{10}{10}$



1 DC 0.94 V

200 MS/s

AUTO

Figure 11. 32-kHz Clock

6.2 Thermal Performance

Figure 12 and Figure 13 show the typical thermal performance for the TPS658640 for both the top side and the bottom side, respectively. $V_{IN} = 5$ V, I_{out} of all of the supplies are set at their maximum load.

6.2.1 Top Side



Figure 12. Thermal Performance – Top Side

6.2.2 Bottom Side

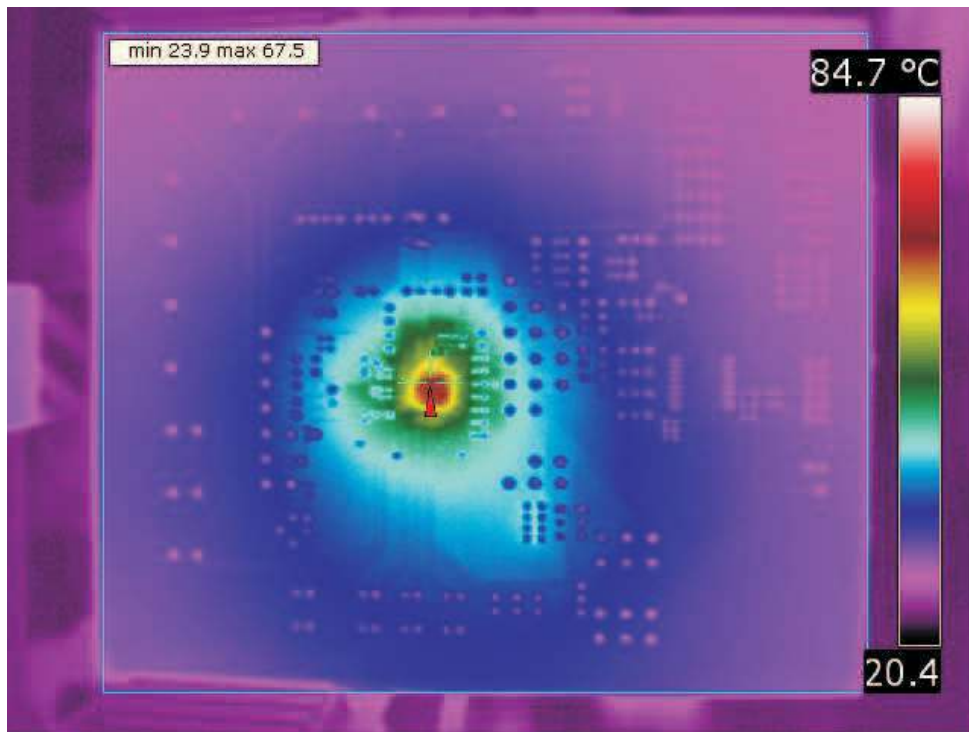

Figure 13. Thermal Performance – Bottom Side

7 EVM Assembly Drawings and Layout

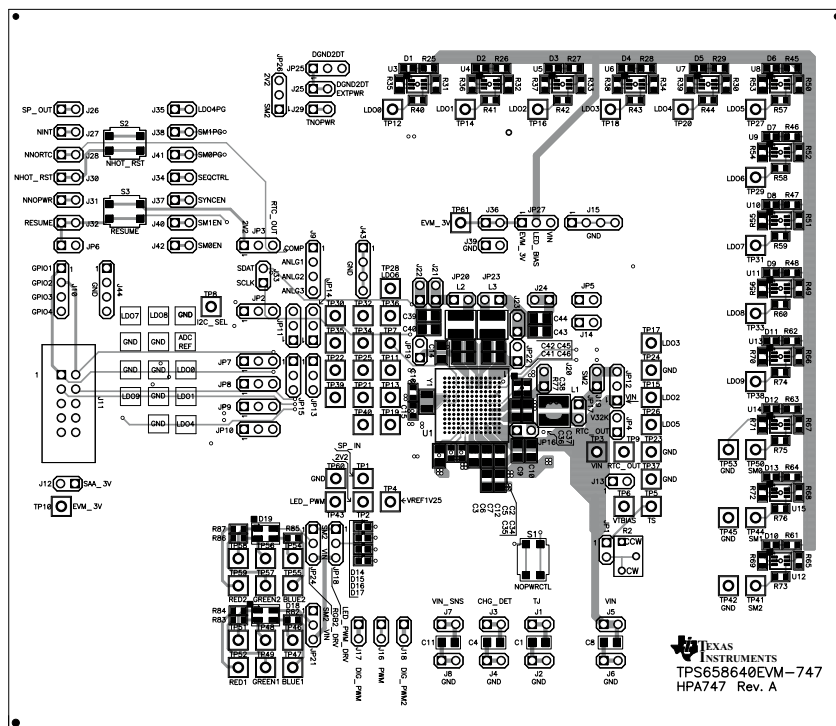

Figure 14. Top Assembly – Silkscreen

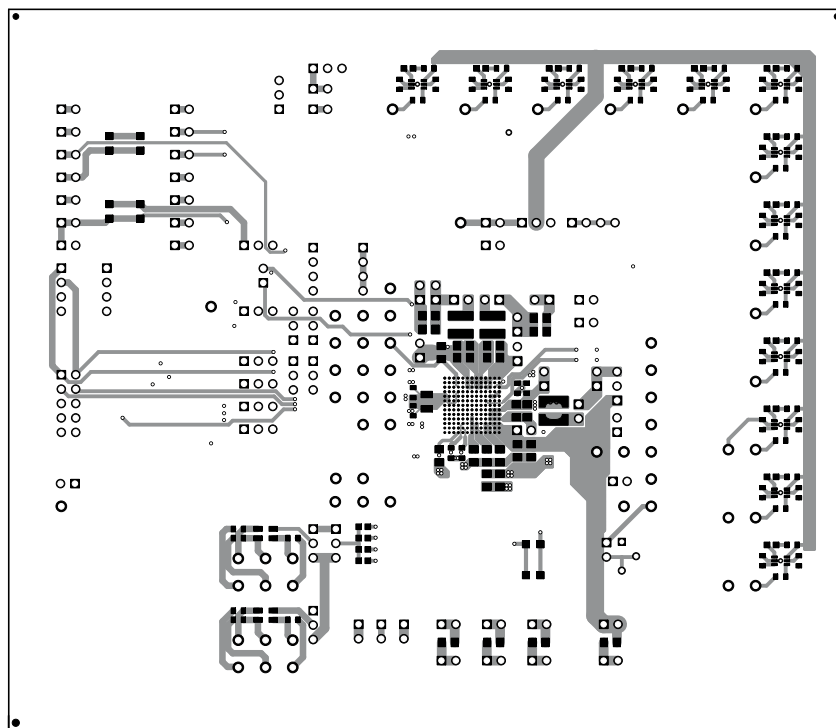

Figure 15. Top Layer

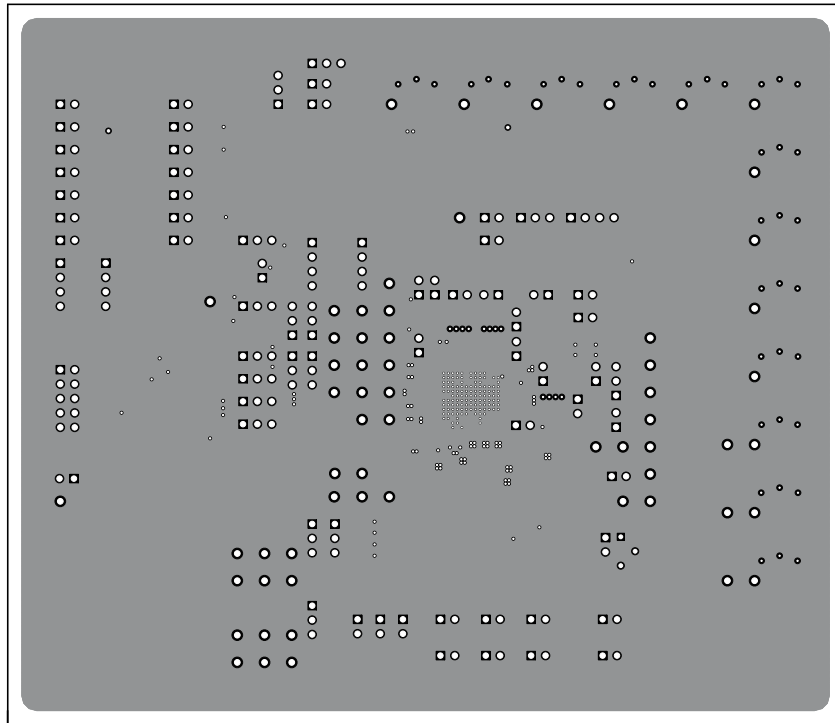

Figure 16. Layer 2

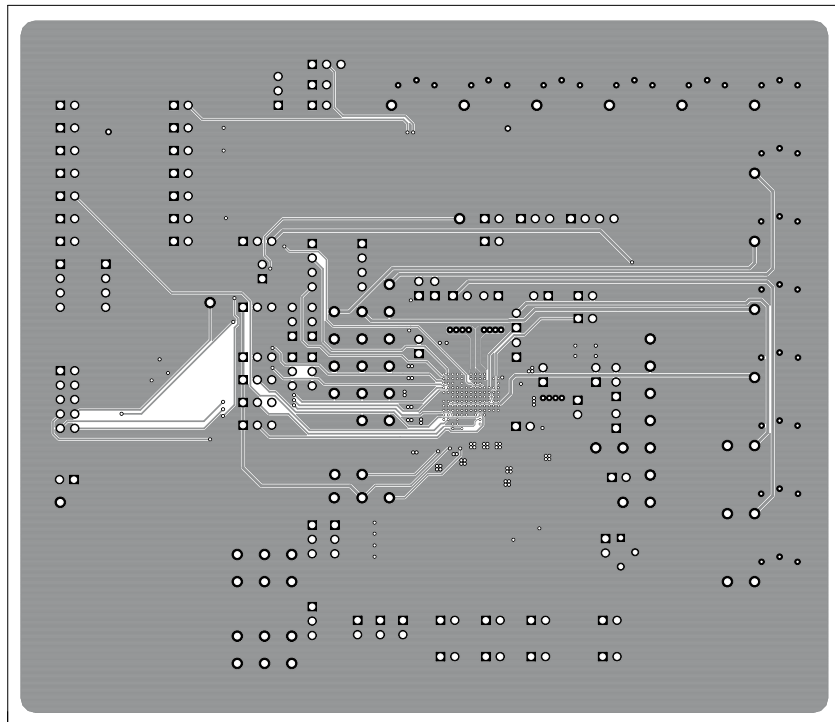

Figure 17. Layer 3

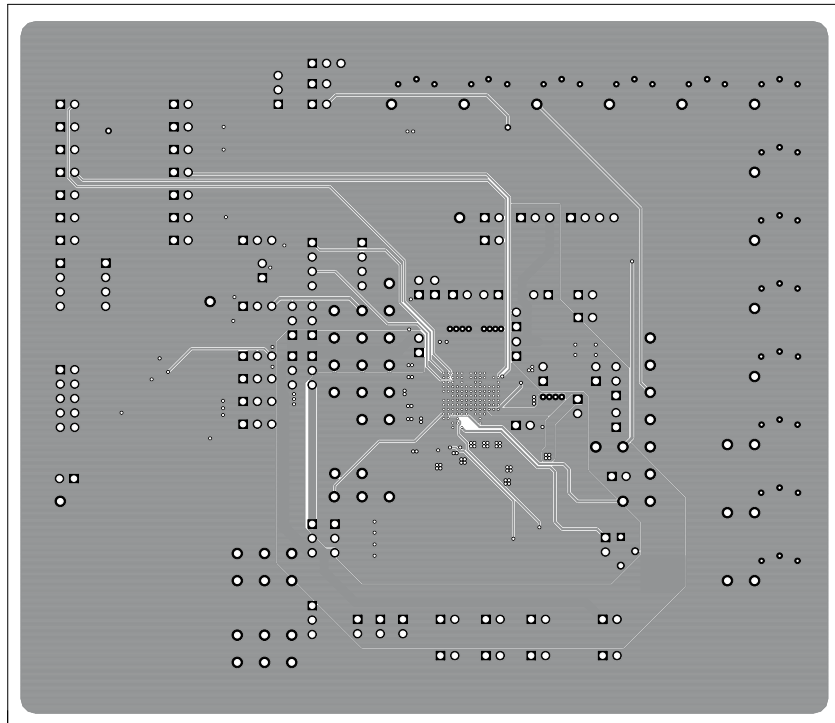

Figure 18. Layer 4

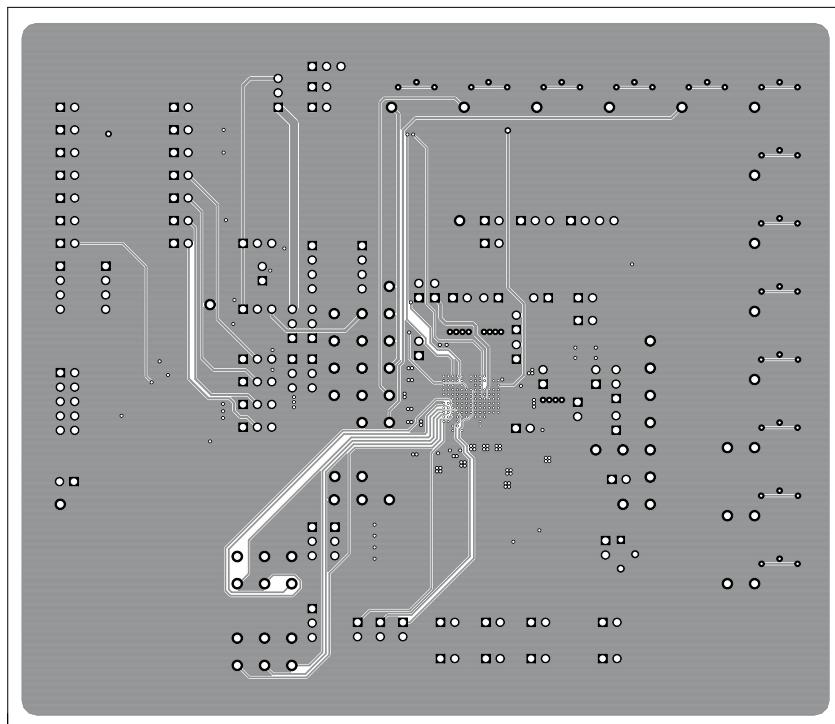

Figure 19. Layer 5

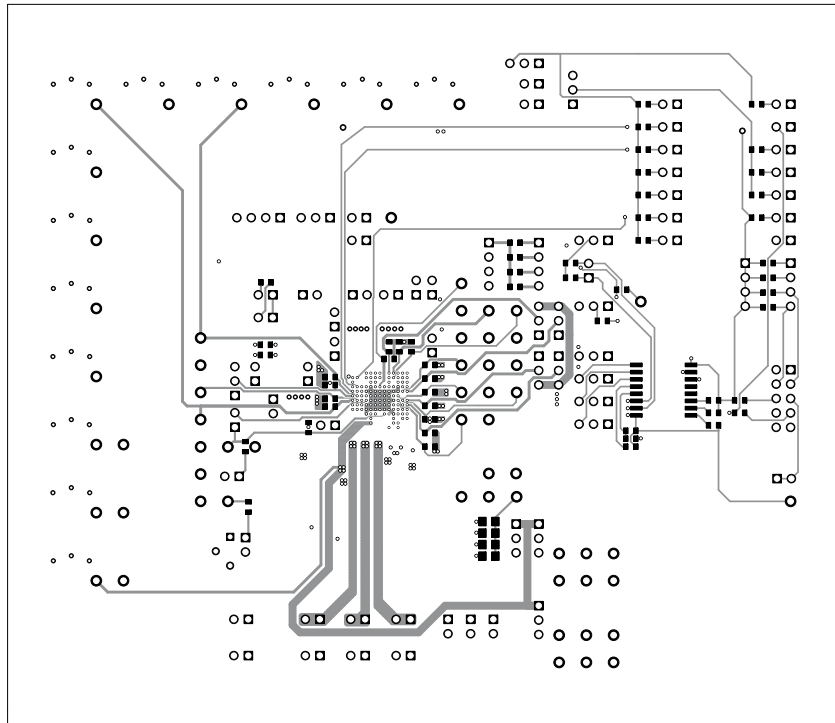

Figure 20. Layer 6

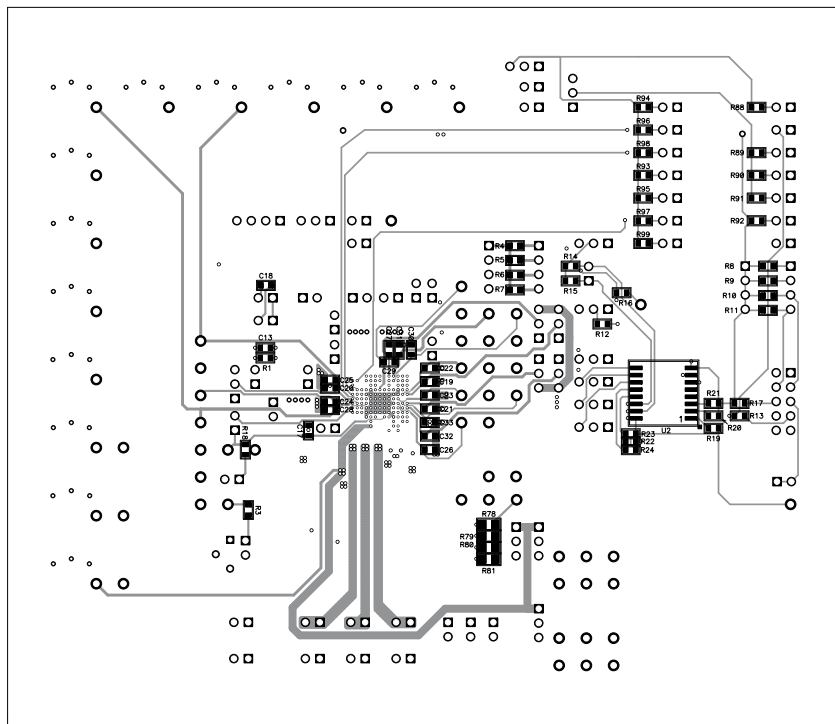

Figure 21. Bottom Layer

8 Bill of Materials
Table 3. Bill of Materials

Count	RefDes	Value	Description	Size	Part Number	MFR
21	C1, C2, C4, C5, C8, C9, C10, C11, C12, C34, C35, C36, C37, C39, C40, C41, C42, C43, C44, C45, C46	10uF	Capacitor, Ceramic, 10V, X5R, 10%	0805	GRM21BR61A106KE19L	muRata
1	C13	2200pF	Capacitor, Ceramic, 50V, C0G, 5%	0603	C1608C0G1H222J	TDK
1	C14	6.8uF	Capacitor, Ceramic, 10V, X5R, 10%	0805	C0805C685K8PACTU	Kemet
3	C15, C16, C38	Open	Capacitor, Ceramic	0603	Std	Std
1	C18	50pF	Capacitor, Ceramic, 50V, C0G, 5%	0603	06035A500JAT2A	AVX
1	C3	4.7uF	Capacitor, Ceramic, 10V, X5R, 10%	0805	GRM219R61A475KE19D	muRata
17	C6, C17, C19, C20, C21, C22, C23, C24, C25, C26, C27, C28, C29, C30, C31, C32, C33	2.2uF	Capacitor, Ceramic, 10V, X5R, 10%	0603	GRM188R61A225KE34D	muRata
1	C7	0.1uF	Capacitor, Ceramic, 50V, X7R, 10%	0603	C1608X7R1H104K	TDK
13	D1, D2, D3, D4, D5, D6, D7, D8, D9, D10, D11, D12, D13	LTST-C190GKT	Diode, LED, Green, 2.1V, 10mA, 6mcd	0603	LTST-C190GKT	Lite On
4	D14, D15, D16, D17	LTW-C193TS5	Diode, LED, White, 2.95V, 5mA	0603	LTW-C193TS5	Lite On
2	D18, D19	LATBT66B	Diode, LED, 20mA, Common Anode	0.118 x 0.134	LATBT66B-ST-1+TU7-35+QS-36-ZB-Z ALTERNATE: LATBT66B-ST-1+TU-35+QR-35-20-R18-ZB	Osram
38	J1, J2, J3, J4, J5, J6, J7, J8, J12, J13, J14, J16, J17, J18, J19, J20, J21, J22, J23, J24, J25, J26, J27, J28, J29, J30, J31, J32, J33, J34, J35, J36, J37, J38, J39, J40, J41, J42	PEC02SAAN	Header, 2 pin, 100mil spacing,	0.100 x 2	PEC02SAAN	Sullins
5	J9, J10, J15, J43, J44	PEC04SAAN	Header, 4 pin, 100mil spacing,	0.100 x 4	PEC04SAAN	Sullins
1	J11	N2510-6002-RB	Connector, Male Straight 2x5 pin, 100mil spacing, 4 Wall	0.338 x 0.788	N2510-6002-RB	3M
10	JP1, JP4, JP5, JP6, JP16, JP17, JP19, JP20, JP22, JP23	PEC02SAAN	Header, 2 pin, 100mil spacing,	0.100 x 2	PEC02SAAN	Sullins
17	JP2, JP3, JP7, JP8, JP9, JP10, JP11, JP12, JP13, JP14, JP15, JP18, JP21, JP24, JP25, JP26, JP27	PEC03SAAN	Header, 3 pin, 100mil spacing,	0.100 x 3	PEC03SAAN	Sullins
1	L1	1.5uH	Inductor, SMT, 3.1A, 78milliohm	0.169 x 0.169 inch	LPS4414-152ML	Coilcraft
2	L2, L3	1.5uH	Inductor, SMT, 2.7A, 70milliohm	0.153 x 0.153 inch	LPS4012-152ML	Coilcraft
6	R1, R19, R20, R21, R23, R24	10k	Resistor, Chip, 1/16W, 1%	0603	Std	Std
2	R13, R17	0	Resistor, Chip, 1/16W, 1%	0603	Std	Std

Table 3. Bill of Materials (continued)

Count	RefDes	Value	Description	Size	Part Number	MFR
1	R18	332	Resistor, Chip, 1/16W, 1%	0603	Std	Std
1	R2	200K	Potentiometer, 1/4 Cermet, 12-Turn, Top-Adjust	0.25x0.17	3266W-1-204LF	Bourns
1	R22	Open	Resistor, Chip, 1/16W	0603	Std	Std
26	R25, R26, R27, R28, R29, R40, R41, R42, R43, R44, R45, R46, R47, R48, R57, R58, R59, R60, R61, R62, R63, R64, R73, R74, R75, R76	1.0k	Resistor, Chip, 1/16W, 1%	0603	Std	Std
4	R3, R89, R90, R91	100k	Resistor, Chip, 1/16W, 1%	0603	Std	Std
8	R4, R5, R6, R7, R12, R14, R15, R16	20k	Resistor, Chip, 1/16W, 1%	0603	Std	Std
1	R77	Open	Resistor, Chip, 1/16W, 1%	0603	Std	Std
4	R78, R79, R80, R81	100	Resistor, Chip, 1/10W, 1%	0805	Std	Std
39	R8, R9, R10, R11, R30, R31, R32, R33, R34, R35, R36, R37, R38, R39, R49, R50, R51, R52, R53, R54, R55, R56, R65, R66, R67, R68, R69, R70, R71, R72, R88, R92, R93, R94, R95, R96, R97, R98, R99	1.0M	Resistor, Chip, 1/16W, 1%	0603	Std	Std
6	R82, R83, R84, R85, R86, R87	10	Resistor, Chip, 1/16W, 1%	0603	Std	Std
3	S1, S2, S3	7914G-1-000E	Switch, 1P1T, PB Momentary, 100mA, SM	0.19 x 0.18 inch	7914G-1-000E	Bourns
38	TP1, TP2, TP3, TP4, TP5, TP6, TP7, TP8, TP9, TP10, TP11, TP12, TP13, TP14, TP15, TP16, TP17, TP18, TP19, TP20, TP26, TP27, TP28, TP29, TP30, TP31, TP32, TP33, TP38, TP39, TP44, TP46, TP48, TP51, TP54, TP56, TP58, TP61	5000	Test Point, Red, Thru Hole Color Keyed	0.100 x 0.100 inch	5000	Keystone
20	TP21, TP22, TP23, TP24, TP25, TP34, TP35, TP36, TP37, TP40, TP42, TP45, TP47, TP49, TP52, TP53, TP55, TP57, TP59, TP60	5001	Test Point, Black, Thru Hole Color Keyed	0.100 x 0.100 inch	5001	Keystone
3	TP41, TP43, TP50	5002	Test Point, White, Thru Hole Color Keyed	0.100 x 0.100 inch	5002	Keystone
1	U1	TPS658640ZGU	IC, Advanced Power Management Unit	BGA	TPS658640ZGU	TI

Table 3. Bill of Materials (continued)

Count	RefDes	Value	Description	Size	Part Number	MFR
1	U2	PCF8574ADW	IC, Remote 8-Bit I/O Expander For I2C Bus	SO-16	PCF8574ADW	TI
13	U3, U4, U5, U6, U7, U8, U9, U10, U11, U12, U13, U14, U15	TLV3011AIDCK	IC, Nanopower, 1.8V, Open-Drain Comparator With Reference	SC70-6	TLV3011AIDCK	TI
1	Y1	32.768KHz	Crystal, 32.768MHz, 12.5pF Capacitance	1.5mm x 3.2mm	CM315-32.768KDZF-UT	Citizen
1	--		PCB, 5.8 In x 5 In x 0.062 In		HPA747	Any
27	--		Shunt, 100-mil, Black	0.100	929950-00	3M

Evaluation Board/Kit Important Notice

Texas Instruments (TI) provides the enclosed product(s) under the following conditions:

This evaluation board/kit is intended for use for **ENGINEERING DEVELOPMENT, DEMONSTRATION, OR EVALUATION PURPOSES ONLY** and is not considered by TI to be a finished end-product fit for general consumer use. Persons handling the product(s) must have electronics training and observe good engineering practice standards. As such, the goods being provided are not intended to be complete in terms of required design-, marketing-, and/or manufacturing-related protective considerations, including product safety and environmental measures typically found in end products that incorporate such semiconductor components or circuit boards. This evaluation board/kit does not fall within the scope of the European Union directives regarding electromagnetic compatibility, restricted substances (RoHS), recycling (WEEE), FCC, CE or UL, and therefore may not meet the technical requirements of these directives or other related directives.

Should this evaluation board/kit not meet the specifications indicated in the User's Guide, the board/kit may be returned within 30 days from the date of delivery for a full refund. **THE FOREGOING WARRANTY IS THE EXCLUSIVE WARRANTY MADE BY SELLER TO BUYER AND IS IN LIEU OF ALL OTHER WARRANTIES, EXPRESSED, IMPLIED, OR STATUTORY, INCLUDING ANY WARRANTY OF MERCHANTABILITY OR FITNESS FOR ANY PARTICULAR PURPOSE.**

The user assumes all responsibility and liability for proper and safe handling of the goods. Further, the user indemnifies TI from all claims arising from the handling or use of the goods. Due to the open construction of the product, it is the user's responsibility to take any and all appropriate precautions with regard to electrostatic discharge.

EXCEPT TO THE EXTENT OF THE INDEMNITY SET FORTH ABOVE, NEITHER PARTY SHALL BE LIABLE TO THE OTHER FOR ANY INDIRECT, SPECIAL, INCIDENTAL, OR CONSEQUENTIAL DAMAGES.

TI currently deals with a variety of customers for products, and therefore our arrangement with the user **is not exclusive.**

TI assumes **no liability for applications assistance, customer product design, software performance, or infringement of patents or services described herein.**

Please read the User's Guide and, specifically, the Warnings and Restrictions notice in the User's Guide prior to handling the product. This notice contains important safety information about temperatures and voltages. For additional information on TI's environmental and/or safety programs, please contact the TI application engineer or visit www.ti.com/esh.

No license is granted under any patent right or other intellectual property right of TI covering or relating to any machine, process, or combination in which such TI products or services might be or are used.

FCC Warning

This evaluation board/kit is intended for use for **ENGINEERING DEVELOPMENT, DEMONSTRATION, OR EVALUATION PURPOSES ONLY** and is not considered by TI to be a finished end-product fit for general consumer use. It generates, uses, and can radiate radio frequency energy and has not been tested for compliance with the limits of computing devices pursuant to part 15 of FCC rules, which are designed to provide reasonable protection against radio frequency interference. Operation of this equipment in other environments may cause interference with radio communications, in which case the user at his own expense will be required to take whatever measures may be required to correct this interference.

EVM Warnings and Restrictions

It is important to operate this EVM within the input voltage range of 2.5 V to 6.4 V and the output voltage range of 8 V to 16 V .

Exceeding the specified input range may cause unexpected operation and/or irreversible damage to the EVM. If there are questions concerning the input range, please contact a TI field representative prior to connecting the input power.

Applying loads outside of the specified output range may result in unintended operation and/or possible permanent damage to the EVM. Please consult the EVM User's Guide prior to connecting any load to the EVM output. If there is uncertainty as to the load specification, please contact a TI field representative.

During normal operation, some circuit components may have case temperatures greater than 50°C. The EVM is designed to operate properly with certain components above 50°C as long as the input and output ranges are maintained. These components include but are not limited to linear regulators, switching transistors, pass transistors, and current sense resistors. These types of devices can be identified using the EVM schematic located in the EVM User's Guide. When placing measurement probes near these devices during operation, please be aware that these devices may be very warm to the touch.

Mailing Address: Texas Instruments, Post Office Box 655303, Dallas, Texas 75265
Copyright © 2011, Texas Instruments Incorporated

EVALUATION BOARD/KIT/MODULE (EVM) ADDITIONAL TERMS

Texas Instruments (TI) provides the enclosed Evaluation Board/Kit/Module (EVM) under the following conditions:

The user assumes all responsibility and liability for proper and safe handling of the goods. Further, the user indemnifies TI from all claims arising from the handling or use of the goods.

Should this evaluation board/kit not meet the specifications indicated in the User's Guide, the board/kit may be returned within 30 days from the date of delivery for a full refund. THE FOREGOING LIMITED WARRANTY IS THE EXCLUSIVE WARRANTY MADE BY SELLER TO BUYER AND IS IN LIEU OF ALL OTHER WARRANTIES, EXPRESSED, IMPLIED, OR STATUTORY, INCLUDING ANY WARRANTY OF MERCHANTABILITY OR FITNESS FOR ANY PARTICULAR PURPOSE. EXCEPT TO THE EXTENT OF THE INDEMNITY SET FORTH ABOVE, NEITHER PARTY SHALL BE LIABLE TO THE OTHER FOR ANY INDIRECT, SPECIAL, INCIDENTAL, OR CONSEQUENTIAL DAMAGES.

Please read the User's Guide and, specifically, the Warnings and Restrictions notice in the User's Guide prior to handling the product. This notice contains important safety information about temperatures and voltages. For additional information on TI's environmental and/or safety programs, please visit www.ti.com/esh or contact TI.

No license is granted under any patent right or other intellectual property right of TI covering or relating to any machine, process, or combination in which such TI products or services might be or are used. TI currently deals with a variety of customers for products, and therefore our arrangement with the user is not exclusive. TI assumes no liability for applications assistance, customer product design, software performance, or infringement of patents or services described herein.

REGULATORY COMPLIANCE INFORMATION

As noted in the EVM User's Guide and/or EVM itself, this EVM and/or accompanying hardware may or may not be subject to the Federal Communications Commission (FCC) and Industry Canada (IC) rules.

For EVMs **not** subject to the above rules, this evaluation board/kit/module is intended for use for ENGINEERING DEVELOPMENT, DEMONSTRATION OR EVALUATION PURPOSES ONLY and is not considered by TI to be a finished end product fit for general consumer use. It generates, uses, and can radiate radio frequency energy and has not been tested for compliance with the limits of computing devices pursuant to part 15 of FCC or ICES-003 rules, which are designed to provide reasonable protection against radio frequency interference. Operation of the equipment may cause interference with radio communications, in which case the user at his own expense will be required to take whatever measures may be required to correct this interference.

General Statement for EVMs including a radio

User Power/Frequency Use Obligations: This radio is intended for development/professional use only in legally allocated frequency and power limits. Any use of radio frequencies and/or power availability of this EVM and its development application(s) must comply with local laws governing radio spectrum allocation and power limits for this evaluation module. It is the user's sole responsibility to only operate this radio in legally acceptable frequency space and within legally mandated power limitations. Any exceptions to this are strictly prohibited and unauthorized by Texas Instruments unless user has obtained appropriate experimental/development licenses from local regulatory authorities, which is responsibility of user including its acceptable authorization.

For EVMs annotated as FCC – FEDERAL COMMUNICATIONS COMMISSION Part 15 Compliant

Caution

This device complies with part 15 of the FCC Rules. Operation is subject to the following two conditions: (1) This device may not cause harmful interference, and (2) this device must accept any interference received, including interference that may cause undesired operation.

Changes or modifications not expressly approved by the party responsible for compliance could void the user's authority to operate the equipment.

FCC Interference Statement for Class A EVM devices

This equipment has been tested and found to comply with the limits for a Class A digital device, pursuant to part 15 of the FCC Rules. These limits are designed to provide reasonable protection against harmful interference when the equipment is operated in a commercial environment. This equipment generates, uses, and can radiate radio frequency energy and, if not installed and used in accordance with the instruction manual, may cause harmful interference to radio communications. Operation of this equipment in a residential area is likely to cause harmful interference in which case the user will be required to correct the interference at his own expense.

FCC Interference Statement for Class B EVM devices

This equipment has been tested and found to comply with the limits for a Class B digital device, pursuant to part 15 of the FCC Rules. These limits are designed to provide reasonable protection against harmful interference in a residential installation. This equipment generates, uses and can radiate radio frequency energy and, if not installed and used in accordance with the instructions, may cause harmful interference to radio communications. However, there is no guarantee that interference will not occur in a particular installation. If this equipment does cause harmful interference to radio or television reception, which can be determined by turning the equipment off and on, the user is encouraged to try to correct the interference by one or more of the following measures:

- Reorient or relocate the receiving antenna.
- Increase the separation between the equipment and receiver.
- Connect the equipment into an outlet on a circuit different from that to which the receiver is connected.
- Consult the dealer or an experienced radio/TV technician for help.

For EVMs annotated as IC – INDUSTRY CANADA Compliant

This Class A or B digital apparatus complies with Canadian ICES-003.

Changes or modifications not expressly approved by the party responsible for compliance could void the user's authority to operate the equipment.

Concerning EVMs including radio transmitters

This device complies with Industry Canada licence-exempt RSS standard(s). Operation is subject to the following two conditions: (1) this device may not cause interference, and (2) this device must accept any interference, including interference that may cause undesired operation of the device.

Concerning EVMs including detachable antennas

Under Industry Canada regulations, this radio transmitter may only operate using an antenna of a type and maximum (or lesser) gain approved for the transmitter by Industry Canada. To reduce potential radio interference to other users, the antenna type and its gain should be so chosen that the equivalent isotropically radiated power (e.i.r.p.) is not more than that necessary for successful communication.

This radio transmitter has been approved by Industry Canada to operate with the antenna types listed in the user guide with the maximum permissible gain and required antenna impedance for each antenna type indicated. Antenna types not included in this list, having a gain greater than the maximum gain indicated for that type, are strictly prohibited for use with this device.

Cet appareil numérique de la classe A ou B est conforme à la norme NMB-003 du Canada.

Les changements ou les modifications pas expressément approuvés par la partie responsable de la conformité ont pu vider l'autorité de l'utilisateur pour actionner l'équipement.

Concernant les EVMs avec appareils radio

Le présent appareil est conforme aux CNR d'Industrie Canada applicables aux appareils radio exempts de licence. L'exploitation est autorisée aux deux conditions suivantes : (1) l'appareil ne doit pas produire de brouillage, et (2) l'utilisateur de l'appareil doit accepter tout brouillage radioélectrique subi, même si le brouillage est susceptible d'en compromettre le fonctionnement.

Concernant les EVMs avec antennes détachables

Conformément à la réglementation d'Industrie Canada, le présent émetteur radio peut fonctionner avec une antenne d'un type et d'un gain maximal (ou inférieur) approuvé pour l'émetteur par Industrie Canada. Dans le but de réduire les risques de brouillage radioélectrique à l'intention des autres utilisateurs, il faut choisir le type d'antenne et son gain de sorte que la puissance isotrope rayonnée équivalente (p.i.r.e.) ne dépasse pas l'intensité nécessaire à l'établissement d'une communication satisfaisante.

Le présent émetteur radio a été approuvé par Industrie Canada pour fonctionner avec les types d'antenne énumérés dans le manuel d'usage et ayant un gain admissible maximal et l'impédance requise pour chaque type d'antenne. Les types d'antenne non inclus dans cette liste, ou dont le gain est supérieur au gain maximal indiqué, sont strictement interdits pour l'exploitation de l'émetteur.

【Important Notice for Users of this Product in Japan】

This development kit is NOT certified as Confirming to Technical Regulations of Radio Law of Japan

If you use this product in Japan, you are required by Radio Law of Japan to follow the instructions below with respect to this product:

1. Use this product in a shielded room or any other test facility as defined in the notification #173 issued by Ministry of Internal Affairs and Communications on March 28, 2006, based on Sub-section 1.1 of Article 6 of the Ministry's Rule for Enforcement of Radio Law of Japan,
2. Use this product only after you obtained the license of Test Radio Station as provided in Radio Law of Japan with respect to this product, or
3. Use of this product only after you obtained the Technical Regulations Conformity Certification as provided in Radio Law of Japan with respect to this product. Also, please do not transfer this product, unless you give the same notice above to the transferee. Please note that if you could not follow the instructions above, you will be subject to penalties of Radio Law of Japan.

Texas Instruments Japan Limited
(address) 24-1, Nishi-Shinjuku 6 chome, Shinjuku-ku, Tokyo, Japan

<http://www.tij.co.jp>

【ご使用にあたっての注】

本開発キットは技術基準適合証明を受けておりません。

本製品のご使用に際しては、電波法遵守のため、以下のいずれかの措置を取っていただく必要がありますのでご注意ください。

1. 電波法施行規則第6条第1項第1号に基づく平成18年3月28日総務省告示第173号で定められた電波暗室等の試験設備でご使用いただく。
2. 実験局の免許を取得後ご使用いただく。
3. 技術基準適合証明を取得後ご使用いただく。

なお、本製品は、上記の「ご使用にあたっての注意」を譲渡先、移転先に通知しない限り、譲渡、移転できないものとします。

上記を遵守頂けない場合は、電波法の罰則が適用される可能性があることをご留意ください。

日本テキサス・インスツルメンツ株式会社
東京都新宿区西新宿6丁目24番1号
西新宿三井ビル

<http://www.tij.co.jp>

EVALUATION BOARD/KIT/MODULE (EVM) WARNINGS, RESTRICTIONS AND DISCLAIMERS

For Feasibility Evaluation Only, in Laboratory/Development Environments. Unless otherwise indicated, this EVM is not a finished electrical equipment and not intended for consumer use. It is intended solely for use for preliminary feasibility evaluation in laboratory/development environments by technically qualified electronics experts who are familiar with the dangers and application risks associated with handling electrical mechanical components, systems and subsystems. It should not be used as all or part of a finished end product.

Your Sole Responsibility and Risk. You acknowledge, represent and agree that:

1. You have unique knowledge concerning Federal, State and local regulatory requirements (including but not limited to Food and Drug Administration regulations, if applicable) which relate to your products and which relate to your use (and/or that of your employees, affiliates, contractors or designees) of the EVM for evaluation, testing and other purposes.
2. You have full and exclusive responsibility to assure the safety and compliance of your products with all such laws and other applicable regulatory requirements, and also to assure the safety of any activities to be conducted by you and/or your employees, affiliates, contractors or designees, using the EVM. Further, you are responsible to assure that any interfaces (electronic and/or mechanical) between the EVM and any human body are designed with suitable isolation and means to safely limit accessible leakage currents to minimize the risk of electrical shock hazard.
3. You will employ reasonable safeguards to ensure that your use of the EVM will not result in any property damage, injury or death, even if the EVM should fail to perform as described or expected.
4. You will take care of proper disposal and recycling of the EVM's electronic components and packing materials.

Certain Instructions. It is important to operate this EVM within TI's recommended specifications and environmental considerations per the user guidelines. Exceeding the specified EVM ratings (including but not limited to input and output voltage, current, power, and environmental ranges) may cause property damage, personal injury or death. If there are questions concerning these ratings please contact a TI field representative prior to connecting interface electronics including input power and intended loads. Any loads applied outside of the specified output range may result in unintended and/or inaccurate operation and/or possible permanent damage to the EVM and/or interface electronics. Please consult the EVM User's Guide prior to connecting any load to the EVM output. If there is uncertainty as to the load specification, please contact a TI field representative. During normal operation, some circuit components may have case temperatures greater than 60°C as long as the input and output are maintained at a normal ambient operating temperature. These components include but are not limited to linear regulators, switching transistors, pass transistors, and current sense resistors which can be identified using the EVM schematic located in the EVM User's Guide. When placing measurement probes near these devices during normal operation, please be aware that these devices may be very warm to the touch. As with all electronic evaluation tools, only qualified personnel knowledgeable in electronic measurement and diagnostics normally found in development environments should use these EVMs.

Agreement to Defend, Indemnify and Hold Harmless. You agree to defend, indemnify and hold TI, its licensors and their representatives harmless from and against any and all claims, damages, losses, expenses, costs and liabilities (collectively, "Claims") arising out of or in connection with any use of the EVM that is not in accordance with the terms of the agreement. This obligation shall apply whether Claims arise under law of tort or contract or any other legal theory, and even if the EVM fails to perform as described or expected.

Safety-Critical or Life-Critical Applications. If you intend to evaluate the components for possible use in safety critical applications (such as life support) where a failure of the TI product would reasonably be expected to cause severe personal injury or death, such as devices which are classified as FDA Class III or similar classification, then you must specifically notify TI of such intent and enter into a separate Assurance and Indemnity Agreement.

Mailing Address: Texas Instruments, Post Office Box 655303, Dallas, Texas 75265
Copyright © 2012, Texas Instruments Incorporated

IMPORTANT NOTICE

Texas Instruments Incorporated and its subsidiaries (TI) reserve the right to make corrections, enhancements, improvements and other changes to its semiconductor products and services per JESD46, latest issue, and to discontinue any product or service per JESD48, latest issue. Buyers should obtain the latest relevant information before placing orders and should verify that such information is current and complete. All semiconductor products (also referred to herein as "components") are sold subject to TI's terms and conditions of sale supplied at the time of order acknowledgment.

TI warrants performance of its components to the specifications applicable at the time of sale, in accordance with the warranty in TI's terms and conditions of sale of semiconductor products. Testing and other quality control techniques are used to the extent TI deems necessary to support this warranty. Except where mandated by applicable law, testing of all parameters of each component is not necessarily performed.

TI assumes no liability for applications assistance or the design of Buyers' products. Buyers are responsible for their products and applications using TI components. To minimize the risks associated with Buyers' products and applications, Buyers should provide adequate design and operating safeguards.

TI does not warrant or represent that any license, either express or implied, is granted under any patent right, copyright, mask work right, or other intellectual property right relating to any combination, machine, or process in which TI components or services are used. Information published by TI regarding third-party products or services does not constitute a license to use such products or services or a warranty or endorsement thereof. Use of such information may require a license from a third party under the patents or other intellectual property of the third party, or a license from TI under the patents or other intellectual property of TI.

Reproduction of significant portions of TI information in TI data books or data sheets is permissible only if reproduction is without alteration and is accompanied by all associated warranties, conditions, limitations, and notices. TI is not responsible or liable for such altered documentation. Information of third parties may be subject to additional restrictions.

Resale of TI components or services with statements different from or beyond the parameters stated by TI for that component or service voids all express and any implied warranties for the associated TI component or service and is an unfair and deceptive business practice. TI is not responsible or liable for any such statements.

Buyer acknowledges and agrees that it is solely responsible for compliance with all legal, regulatory and safety-related requirements concerning its products, and any use of TI components in its applications, notwithstanding any applications-related information or support that may be provided by TI. Buyer represents and agrees that it has all the necessary expertise to create and implement safeguards which anticipate dangerous consequences of failures, monitor failures and their consequences, lessen the likelihood of failures that might cause harm and take appropriate remedial actions. Buyer will fully indemnify TI and its representatives against any damages arising out of the use of any TI components in safety-critical applications.

In some cases, TI components may be promoted specifically to facilitate safety-related applications. With such components, TI's goal is to help enable customers to design and create their own end-product solutions that meet applicable functional safety standards and requirements. Nonetheless, such components are subject to these terms.

No TI components are authorized for use in FDA Class III (or similar life-critical medical equipment) unless authorized officers of the parties have executed a special agreement specifically governing such use.

Only those TI components which TI has specifically designated as military grade or "enhanced plastic" are designed and intended for use in military/aerospace applications or environments. Buyer acknowledges and agrees that any military or aerospace use of TI components which have **not** been so designated is solely at the Buyer's risk, and that Buyer is solely responsible for compliance with all legal and regulatory requirements in connection with such use.

TI has specifically designated certain components which meet ISO/TS16949 requirements, mainly for automotive use. Components which have not been so designated are neither designed nor intended for automotive use; and TI will not be responsible for any failure of such components to meet such requirements.

Products

Audio	www.ti.com/audio
Amplifiers	amplifier.ti.com
Data Converters	dataconverter.ti.com
DLP® Products	www.dlp.com
DSP	dsp.ti.com
Clocks and Timers	www.ti.com/clocks
Interface	interface.ti.com
Logic	logic.ti.com
Power Mgmt	power.ti.com
Microcontrollers	microcontroller.ti.com
RFID	www.ti-rfid.com
OMAP Applications Processors	www.ti.com/omap
Wireless Connectivity	www.ti.com/wirelessconnectivity

Applications

Automotive and Transportation	www.ti.com/automotive
Communications and Telecom	www.ti.com/communications
Computers and Peripherals	www.ti.com/computers
Consumer Electronics	www.ti.com/consumer-apps
Energy and Lighting	www.ti.com/energy
Industrial	www.ti.com/industrial
Medical	www.ti.com/medical
Security	www.ti.com/security
Space, Avionics and Defense	www.ti.com/space-avionics-defense
Video and Imaging	www.ti.com/video

TI E2E Community

e2e.ti.com