

## MODEL CUB7P PROGRAMMABLE ELECTRONIC 8-DIGIT COUNTER



- LCD, POSITIVE IMAGE REFLECTIVE OR NEGATIVE IMAGE TRANSMISSIVE WITH YELLOW/GREEN OR RED LED BACKLIGHTING (9-28 VDC power supply required for versions with LED backlighting)
- AVAILABLE WITH LOW SPEED CONTACT (30 Hz MAX.), HIGH SPEED LOGIC (10 KHz MAX.)
- PRESCALER FROM 0.0001 TO 1.9999
- SELECTABLE DECIMAL POINTS
- REPLACEABLE INTERNAL LITHIUM BATTERY PROVIDES UP TO 6 YEARS OF UNINTERRUPTED OPERATION (Battery Included)
- WIRE CONNECTIONS VIA SCREW CLAMP TYPE TERMINALS
- FRONT PANEL AND REMOTE RESET INPUT
- NEMA 4X/IP65 SEALED FRONT BEZEL
- BOTH FRONT PANEL PROGRAM AND RESET BUTTONS ARE INDIVIDUALLY ENABLED

### DESCRIPTION

The CUB7P is an 8-digit miniature programmable counter with large 0.35 inch (8.90 mm) high digits. It has an LCD read-out available in Positive Image Reflective, Negative Image Transmissive with yellow/green backlighting, or red backlighting. Backlight units require an external 9 to 28 VDC power supply.

The CUB7P is available in either Low Speed Contact or High Speed Logic. The Contact versions (CUB7P0xxx) operate from a switch contact or an NPN open collector transistor. The Logic versions (CUB7P2xx) operate from 3 VDC logic output or from an NPN open collector transistor.

The CUB7P has a programmable prescaler that can be set for any value between 0.0001 and 1.9999. The decimal point position can be set anywhere from 0 (no D.P.) to 0.000000 or no Leading Zero Blanking. Both the prescaler and DP selection are accessed using the front panel PGM and RESET push buttons. See Programming for details. Note that the count, prescaler and DP values will be lost if the battery is removed. See BATTERY INSTALLATION for additional information.

The CUB7P counters use a CMOS LSI chip, mounted on a gold-plated substrate, that is electrically connected by ultrasonic wire-bonding. Proven micro-electronic assembly and manufacturing techniques provide these units with the reliability and dependability required for industrial service.

The CUB7P series is housed in a lightweight, high impact plastic case with a clear viewing window. The sealed front panel with the silicone rubber buttons meets NEMA 4X/IP65 specifications for wash-down and/or dusty environments, when properly installed.

### SAFETY SUMMARY

All safety related regulations, local codes and instructions that appear in the manual or on equipment must be observed to ensure personal safety and to prevent damage to either the instrument or equipment connected to it. If equipment is used in a manner not specified by the manufacturer, the protection provided by the equipment may be impaired.

Do not use this unit to directly command motors, valves, or other actuators not equipped with safeguards. To do so, can be potentially harmful to persons or equipment in the event of a fault to the unit.



**CAUTION: Risk of Danger.**  
 Read complete instructions prior to installation and operation of the unit.

### ORDERING INFORMATION

MODEL NO.	DESCRIPTION	PART NUMBER	
*CUB7P	LOW SPEED CONTACT INPUT	Counter; Positive Image Reflective	CUB7P000
		Counter, w/Yel-Grn Backlighting	CUB7P010
		Counter; w/Red Backlighting	CUB7P020
	HIGH SPEED LOGIC INPUT	Counter; Positive Image Reflective	CUB7P200
		Counter, w/Yel-Grn Backlighting	CUB7P210
		Counter; w/Red Backlighting	CUB7P220
BNL	Replacement 3 V Lithium Battery	BNL10000	

\* Battery is included with unit.

### DIMENSIONS In inches (mm)

Note: Recommended minimum clearance (behind the panel) for mounting clip installation is 2.15" (54.6) H x 3.00" (76.2) W.

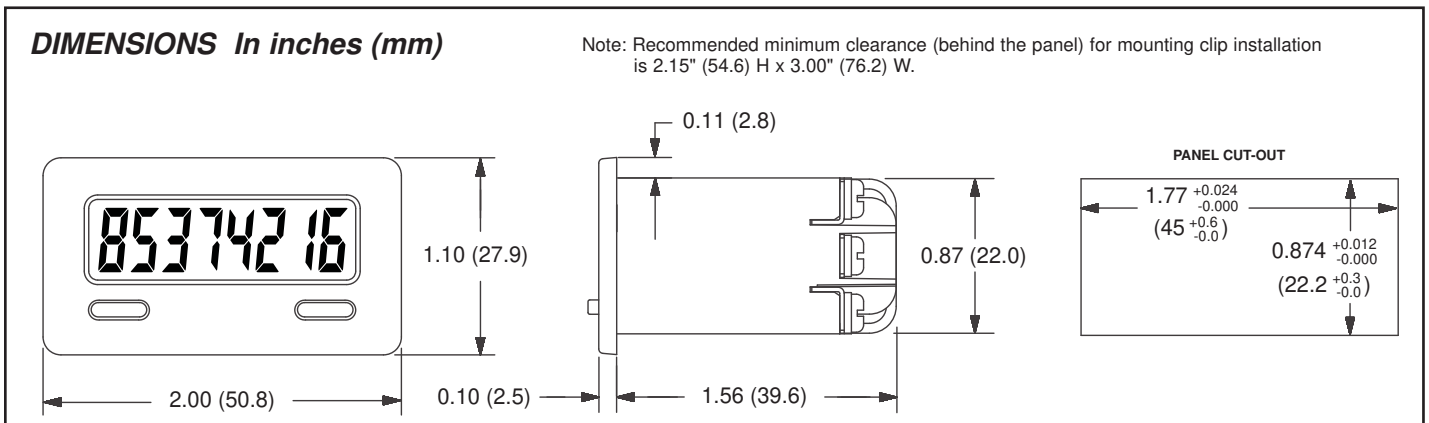

## SPECIFICATIONS

- DISPLAY:** 8-digit LCD, 0.35" (8.90 mm) high digits.
- POWER SOURCE:** Replaceable Internal 3.0 V lithium battery to provide up to 6 years of continuous operation. (Battery life is dependent upon usage. Contacts that remain closed for long periods of time reduce battery life.)
- BACKLIGHT POWER REQUIREMENTS:** 9 to 28 VDC; 35 mA. typical, 50 mA max. Above 26 VDC, derate max. operating temperature to 40°C. Must use NEC Class 2 or SELV rated power supply.
- SIGNAL INPUT:** (LS terminal #4) See *Count Edge* under Programming for incrementing edge of input signal.

**Contact Input** (CUB7P0xx): 30 Hz max. from Switch Contact or solid state Transistor Switch to Common with a 50% duty cycle. Contact burden 7  $\mu$ A max.

**Logic Input** (CUB7P2xx): 10 KHz max. from a 3.0V bipolar output or 200 Hz max. from a solid state Transistor Switch to Common with a 50% duty cycle. Contact burden 7  $\mu$ A max.

- REMOTE RESET:** 15 msec min. pulse width (active low) from 3.0 V bipolar output, an open collector transistor, or a switch contact to common.
- ENVIRONMENTAL CONDITIONS:**

**Operating Temperature Range:** 0 to 50°C Derate max. operating temperature to 40°C above 26 VDC (Backlight versions).

**Storage Temperature:** -30 to 80°C

**Operating and Storage Humidity:** 85% max. relative humidity (non-condensing) from 0°C to 50°C.

**Vibration According to IEC 68-2-6:** Operational 5 to 500 Hz, in X, Y, Z direction for 1.5 hours, 5 g's.

**Shock According to IEC 68-2-27:** Operational 30 g's, 11 msec in 3 directions.

**Altitude:** Up to 2000 meters

- CERTIFICATIONS AND COMPLIANCES:**

### SAFETY

Type 4X Indoor Enclosure rating (Face only)

IEC-61010-1, EN 61010-1: Safety requirements for electrical equipment for measurement, control, and laboratory use, Part 1.

IP65 Enclosure rating (Face only), IEC 529

## ELECTROMAGNETIC COMPATIBILITY

### Immunity to EN 50082-2

Electrostatic discharge	EN 61000-4-2	Level 2; 4 Kv contact Level 3; 8 Kv air
Electromagnetic RF fields	EN 61000-4-3	Level 3; 10 V/m 80 MHz - 1 GHz
Fast transients (burst)	EN 61000-4-4	Level 4; 2 Kv I/O Level 3; 2 Kv power <sup>1</sup>
RF conducted interference	EN 61000-4-6	Level 3; 10 V/rms 150 KHz - 80 MHz
Simulation of cordless telephone	ENV 50204	Level 3; 10 V/m 900 MHz $\pm$ 5 MHz 200 Hz, 50% duty cycle

### Emissions to EN 50081-1

RF interference	EN 55022	Enclosure class B
-----------------	----------	-------------------

### Notes

1. Backlit powered units require a power line filter to be installed, RLC LFIL0000 or equivalent, so as not to impair the function of the backlighting.

Refer to EMC Installation Guidelines for additional information.

- CONNECTIONS:** Wire clamping screw terminals  
**Wire Strip Length:** 0.3" (7.5 mm)  
**Wire Gauge:** 30-14 AWG copper wire  
**Torque:** 5 inch-lbs (0.565 N-m) max.
- CONSTRUCTION:** High impact plastic case with clear viewing window. The front panel meets NEMA 4X/IP65 requirements for indoor use when properly installed. Installation Category I, Pollution Degree 2. Panel gasket and mounting clip included.
- WEIGHT:** 2 oz. (57 grams) [with battery]

## PROGRAMMING

The CUB7P has programmable prescale values and decimal point positions. These values are changed using the front panel push buttons. Connect wires between RST EN (Reset Enable) and COM. (Common); and between HS (Program Enable) and COM. (Common) to enable front panel push buttons.

*Note: Upon entering the PGM mode for the first time, the Prescaler value is set to 0.0000. Some value between 0.0001 and 1.9999 must be entered in order for the CUB7P to operate properly. Previously stored values are retained until changed by the user.*

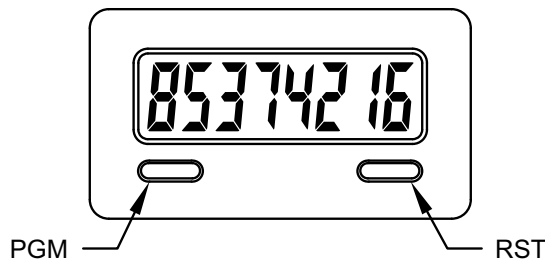

With the front panel push buttons enabled, press the PGM button to enter the program mode. The CUB7P display will change to the current prescale value, with the least significant digit flashing at a 2 Hz rate. The prescale value can be set to any value between 0.0001 and 1.9999. Press the RST button to increment the flashing digit to the desired value. Pressing the PGM button will lock in the value of the flashing digit and advance to the next significant digit. The most significant digit can only be set to 0 or 1. When the entire prescale value has been programmed, press the PGM button once to enable decimal point selection. Any new count pulses will be accumulated using the new prescale value.

After performing the prescale selection, the display will show 0.0000. Decimal point positions can be set for:

0  
0.0  
0.00  
0.000  
0.0000 (Default)  
0.00000  
0.000000  
0.0000000

Press the RST button until the desired decimal point position is displayed. Press the PGM button to select that position and return to the counter mode. Remove the wire from the HS (Program Enable) terminal to prevent accidental changes to the programmed values.

*Note: The incrementing edge of the count signal will change when the PGM button is pressed for the first time. To avoid incorrect display information, it is recommended that the CUB7P be reset after making programming changes.*

## COUNT EDGE

Accessing program mode for the first time will complement the incrementing edge of the count signal. The table below shows the incrementing edge of the count signal for the different versions of the CUB7P.

VERSION	AFTER INSTALLING OR REPLACING BATTERY	AFTER ENTERING PROGRAM MODE
CUB7P0 (Contact)	Rising Edge	Falling Edge
CUB7P2 (Logic)	Rising Edge	Falling Edge

## EMC INSTALLATION GUIDELINES

Although this unit is designed with a high degree of immunity to ElectroMagnetic Interference (EMI), proper installation and wiring methods must be followed to ensure compatibility in each application. The type of the electrical noise, source or coupling method into the unit may be different for various installations. In extremely high EMI environments, additional measures may be needed. The unit becomes more immune to EMI with fewer I/O connections. Cable length, routing and shield termination are very important and can mean the difference between a successful or a troublesome installation. Listed below are some EMC guidelines for successful installation in an industrial environment.

- Use shielded (screened) cables for all Signal and Control inputs. The shield (screen) pigtail connection should be made as short as possible. The connection point for the shield depends somewhat upon the application. Listed below are the recommended methods of connecting the shield, in order of their effectiveness.
  - Connect the shield only at the panel where the unit is mounted to earth ground (protective earth).
  - Connect the shield to earth ground at both ends of the cable, usually when the noise source frequency is above 1 MHz.
  - Connect the shield to common of the unit and leave the other end of the shield unconnected and insulated from earth ground.
- Never run Signal or Control cables in the same conduit or raceway with AC power lines, conductors feeding motors, solenoids, SCR controls, and heaters, etc. The cables should be run in metal conduit that is properly grounded. This is especially useful in applications where cable runs are long and portable two-way radios are used in close proximity or if the installation is near a commercial radio transmitter.
- Signal or Control cables within an enclosure should be routed as far away as possible from contactors, control relays, transformers, and other noisy components.

- In extremely high EMI environments, the use of external EMI suppression devices, such as ferrite suppression cores, is effective. Install them on Signal and Control cables as close to the unit as possible. Loop the cable through the core several times or use multiple cores on each cable for additional protection. Install line filters on the power input cable to the unit to suppress power line interference. Install them near the power entry point of the enclosure. The following EMI suppression devices (or equivalent) are recommended:

Ferrite Suppression Cores for signal and control cables:

Fair-Rite # 0443167251 (RLC #FCOR0000)

TDK # ZCAT3035-1330A

Steward #28B2029-0A0

Line Filters for input power cables:

Schaffner # FN610-1/07 (RLC #LFIL0000)

Schaffner # FN670-1.8/07

Corcom #1VR3

*Note: Reference manufacturer's instructions when installing a line filter.*

- Long cable runs are more susceptible to EMI pickup than short cable runs. Therefore, keep cable runs as short as possible.

## WIRING CONNECTIONS

The electrical connections are made via screw-clamp terminals located on the back of the unit. All conductors should meet voltage and current ratings for each terminal. Also, cabling should conform to appropriate standards of good installation, local codes and regulations. It is recommended that power supplied to the unit be protected by a fuse or circuit breaker. When wiring the unit, use the battery cover to identify the wire position with the proper function. Strip the wire, leaving approximately 1/4" bare wire exposed (stranded wires should be tinned with solder). Insert the wire under the screw-clamp and tighten down the screw until the wire is clamped in tightly. Each terminal can accept up to two #14 AWG wires.

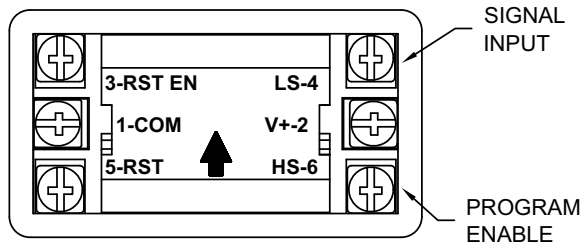

 **WARNING:** Lithium battery may explode if incinerated.

## BATTERY INSTALLATION

- Remove all power to the unit before removing battery cover.
- To remove the battery cover, push upward in the direction of the arrow on the rear cover (See drawing below), until the cover unlatches. Pull the cover straight out from unit to fully remove.
- Remove old battery\* and replace it with an RLC battery (BNL10000). Observe proper polarity when replacing the battery as shown in the drawing.
- Replace the cover. The battery cover is keyed so that it cannot be placed upside down. The arrow on the rear of the cover should point toward the top of the CUB7P when properly installed.

\* - Dispose of properly.

 **WARNING:** Lithium battery may explode if incinerated.

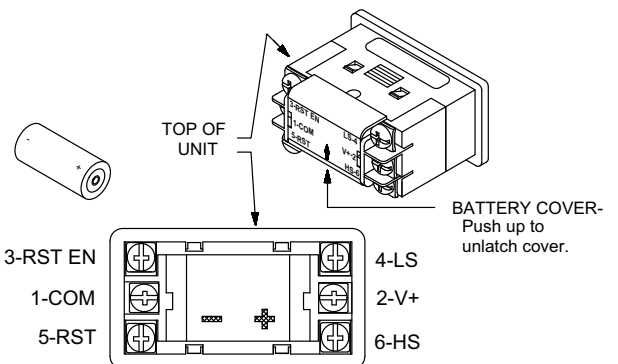

## INSTALLATION ENVIRONMENT

The unit should be installed in a location that does not exceed the maximum operating temperature and provides good air circulation. Placing the unit near devices that generate excessive heat should be avoided.

The bezel should be cleaned only with a soft cloth and neutral soap product. Do NOT use solvents.

Continuous exposure to direct sunlight may accelerate the aging process of the bezel.

Do not use tools of any kind (screwdrivers, pens, pencils, etc.) to operate the push buttons of the unit.

## INSTALLATION

The CUB7P meets NEMA 4X/IP65 requirements for indoor use when properly installed. The units are intended to be mounted into an enclosed panel. The viewing window and reset button are factory sealed for a washdown environment. A sponge rubber gasket and mounting clip are provided for installing the unit in the panel cut-out.

The following procedure assures proper installation:

1. Cut panel opening to specified dimensions. Remove burrs and clean around panel opening.
2. Carefully remove and discard the center section of the gasket.
3. Slide the panel gasket over the rear of the counter body to the back of the bezel. Install CUB7P unit through the panel cut-out.
4. Insert the mounting screws onto both sides of mounting clip. Tip of screw should NOT project from hole in mounting clip.
5. Slide the mounting clip over the rear of the unit until the clip is against the back of the panel. The mounting clip has latching features which engage into mating features on the CUB7P housing.
6. Note: It is necessary to hold the unit in place when sliding mounting clip into position.
7. Alternately tighten each screw to ensure uniform gasket pressure. Visually inspect the front panel gasket. The gasket should be compressed to about 75 to 80% of its original thickness. If not, gradually turn mounting screws to further compress gasket.
8. If the gasket is not adequately compressed and the mounting screws can no longer be turned, loosen mounting screws, and check that the mounting clip is latched as close as possible to the panel.
9. Repeat from step #5 for tightening mounting screws.

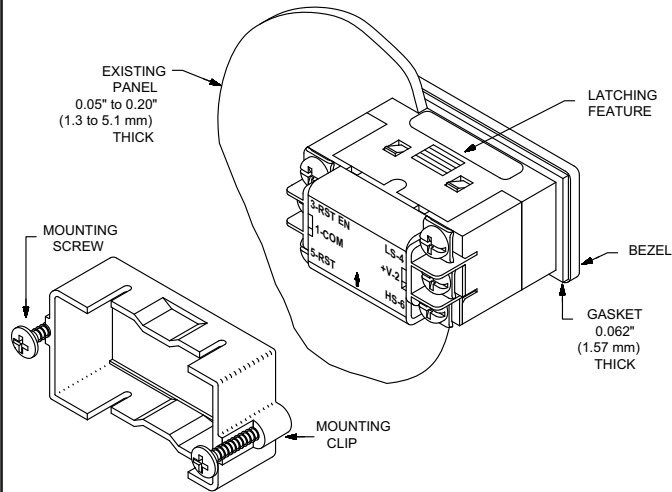

## L.S. INPUT; LOGIC VERSIONS (10 KHz MAX.)

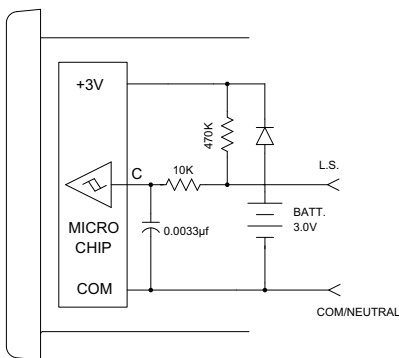

TTL OR CMOS OUTPUT

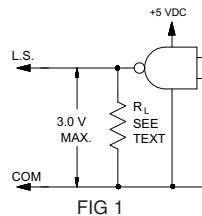

FIG 1

PNP O.C. TRANSISTOR OR BI-POLAR OUTPUT

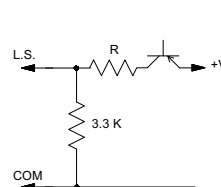

FIG 2

NPN O.C. TRANSISTOR

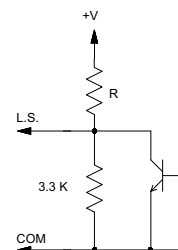
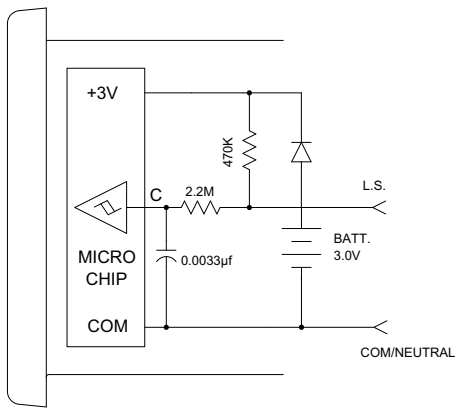

FIG 3

The "L.S." Input allows the CUB7P to operate at speeds up to 10 KHz when driven by bi-polar outputs or external circuits having an output impedance of 3.3 KΩ or less. Input drive voltage must be limited to 3 V maximum to avoid damage to the counter. CMOS and TTL Logic outputs can be loaded with a resistor ( $R_1$ ) to limit drive voltage, or a voltage divider can be used as shown for the PNP O.C. Transistor output.

R values for Fig 2 & 3	
+V	R
+5 V	2.2 K
+12 V	10 K
+18 V	16 K
+24 V	24 K

## L.S. INPUT; CONTACT VERSIONS (30 Hz MAX.)



Connecting the "L.S." Input to Common with a mechanical or solid-state switch increments the counter. The switch load is  $7 \mu\text{A}$  (max. voltage drop 0.5 V) when ON. The OFF-state leakage current must be less than  $2 \mu\text{A}$ .

SWITCH  
CONTACT  
INPUT

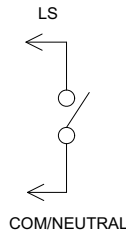

NPN  
O.C. TRANSISTOR  
OR (N) FET  
INPUT

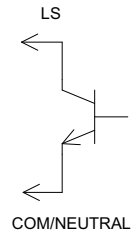

PNP  
O.C. TRANSISTOR  
OR (P) FET  
INPUT

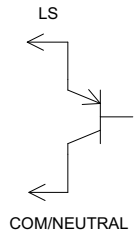

Reed switches, mercury wetted contacts, snap action limit switches, and silver alloy relay contacts with wiping action are usually satisfactory for input activation. Motor starter contacts, tungsten contacts, and brush-type contacts should not be used.

## RESET AND PROGRAM OPTIONS

Connecting a wire from the RST EN (Reset Enable) or the HS (Program Enable) Input terminals to Common will enable the front panel Reset or Program buttons respectively.

Pulling the "RST." input low causes the counter to reset. The "RST." can be pulled low by either a mechanical switch or solid-state transistor switch. The Switch load is  $15 \mu\text{A}$  (max. voltage drop 0.5 V) when ON. The OFF-state leakage current must be less than  $2 \mu\text{A}$ .

*Note: The RC protection circuit on the "RST." Input causes a delay of approximately 15 msec in Reset response.*

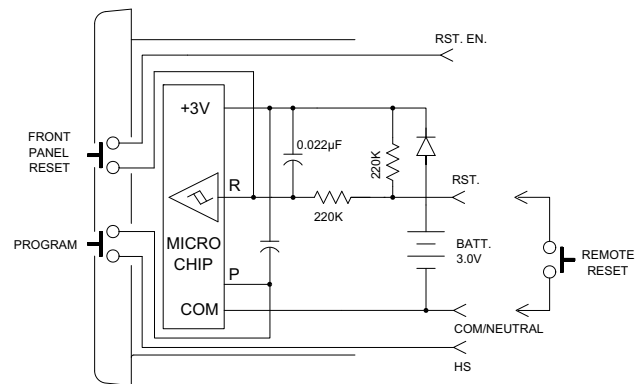

## BACKLIGHT OPTION

Optional backlight versions of the CUB7P require an external 9 to 26 VDC power supply. The external supply is connected between the V+ and common terminals as shown in the drawing.

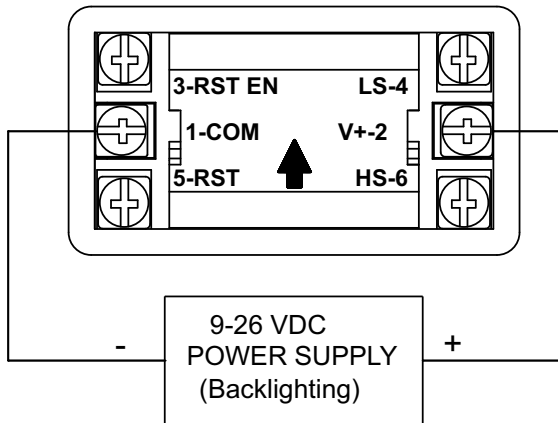

## PROGRAMMING EXAMPLES

### SCALING A COUNTER

**Example:** An encoder generates 600 pulses per foot. The Desired Display is tenths of inches. The Prescaler is determined using the formula below.

$$\text{Prescaler} = \frac{1 \text{ (inch)} \times 10 \text{ (Decimal Point Value)}}{600 \text{ pulses/foot} \times 1 \text{ foot/ 12 inches}}$$

**Where:**

**Desired Display** = The number of Desired Display units (revolutions, feet, 10ths of feet, meters, etc.).

**Number of Pulses** = The number of pulses required to achieve the Desired Display

**Decimal Point Value** = The desired decimal point placement on the display.

Decimal Point Value	Multiply By
0	1
0.0	10
0.00	100
0.000	1000
0.0000	10000
0.00000	100000

**Example:** Display tenths of inches when using

$$\begin{aligned} \text{Prescaler} &= \frac{\text{Desired Display Units} \times \text{Decimal Point Value}}{\text{Number of Pulses}} \\ &= 10/50 = 0.2 \end{aligned}$$

## APPLICATION - TOTAL YARDS OF MATERIAL

A fabric manufacturer wants to know, as economically as possible, how many whole yards of material his lines are running. The CUB7P000 will meet his process requirements. The encoder measuring the material, generates a one pulse per foot output signal. To obtain the desired display of yards measured, a prescale value of 0.3333 is programmed. To program the prescale value, connect wires between RST EN (Reset Enable) and COM. (Common); and between HS (Program Enable) and COM. (Common) to enable the front panel push buttons (See *PROGRAMMING* for more details.). Remove these wires after programming to prevent accidental changes to the prescale value. At the end of each shift, the machine operator records the total shown on the display and resets the counter to zero via key switch.

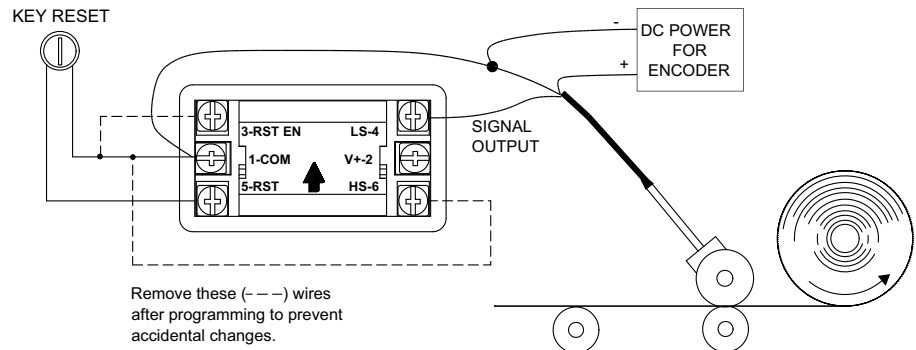

## TROUBLESHOOTING

For further technical assistance, contact technical support at the appropriate company numbers listed.

This page intentionally left blank

#### LIMITED WARRANTY

The Company warrants the products it manufactures against defects in materials and workmanship for a period limited to two years from the date of shipment, provided the products have been stored, handled, installed, and used under proper conditions. The Company's liability under this limited warranty shall extend only to the repair or replacement of a defective product, at The Company's option. The Company disclaims all liability for any affirmation, promise or representation with respect to the products.

The customer agrees to hold Red Lion Controls harmless from, defend, and indemnify RLC against damages, claims, and expenses arising out of subsequent sales of RLC products or products containing components manufactured by RLC and based upon personal injuries, deaths, property damage, lost profits, and other matters which Buyer, its employees, or sub-contractors are or may be to any extent liable, including without limitation penalties imposed by the Consumer Product Safety Act (P.L. 92-573) and liability imposed upon any person pursuant to the Magnuson-Moss Warranty Act (P.L. 93-637), as now in effect or as amended hereafter.

No warranties expressed or implied are created with respect to The Company's products except those expressly contained herein. The Customer acknowledges the disclaimers and limitations contained herein and relies on no other warranties or affirmations.

Red Lion Controls  
Headquarters  
20 Willow Springs Circle  
York PA 17406  
Tel +1 (717) 767-6511  
Fax +1 (717) 764-0839

Red Lion Controls  
Europe  
Printerweg 10  
NL - 3821 AD Amersfoort  
Tel +31 (0) 334 723 225  
Fax +31 (0) 334 893 793

Red Lion Controls  
India  
54, Vishvas Tenement  
GST Road, New Ranip,  
Ahmedabad-382480 Gujarat, India  
Tel +91 987 954 0503  
Fax +91 79 275 31 350

Red Lion Controls  
China  
Unit 101, XinAn Plaza  
Building 13, No.99 Tianzhou Road  
ShangHai, P.R. China 200223  
Tel +86 21 6113-3688  
Fax +86 21 6113-3683