

THIS DRAWING IS UNPUBLISHED.

RELEASED FOR PUBLICATION

20

© COPYRIGHT 20 BY -

ALL RIGHTS RESERVED.

REVISIONS

P	LTR	DESCRIPTION	DATE	DWN	APVD
	A	INITIAL	11APR2017	BS	CW

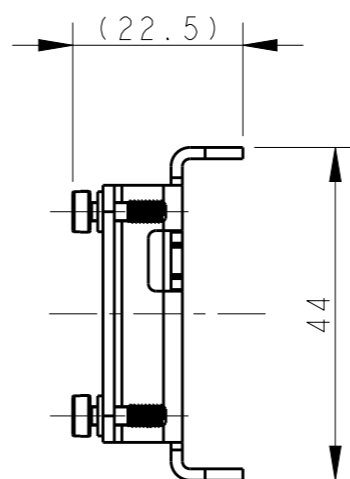
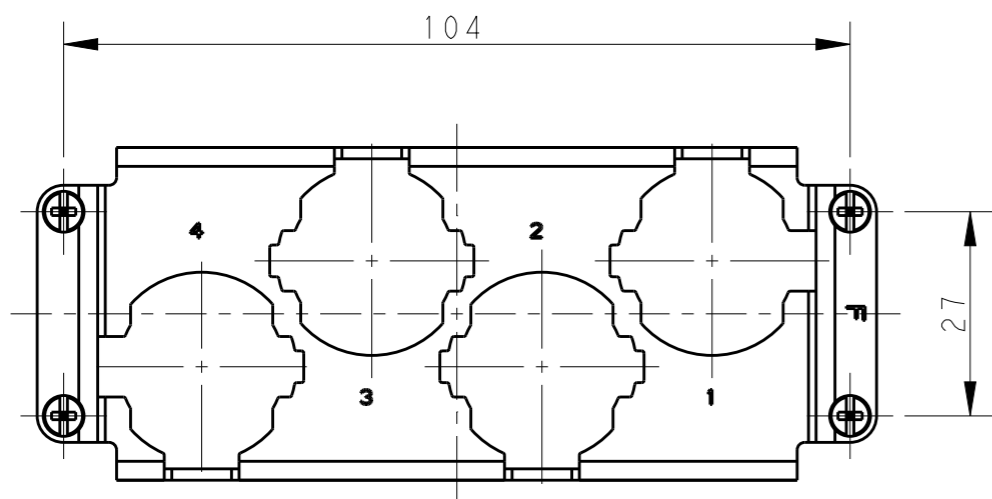

NOTES:

TECHNICAL CHARACTERISTICS:
 FRAME MATERIAL: STAINLESS STEEL
 NUMBER OF MODULES: 4

注释:

技术参数:
 框架材料: 不锈钢
 模块数量: 4

4X M3 SCREW
 RECOMMENDED TIGHTENING
 TORQUE 0.5Nm
 4X M3螺丝, 推荐扭力矩为0.5Nm

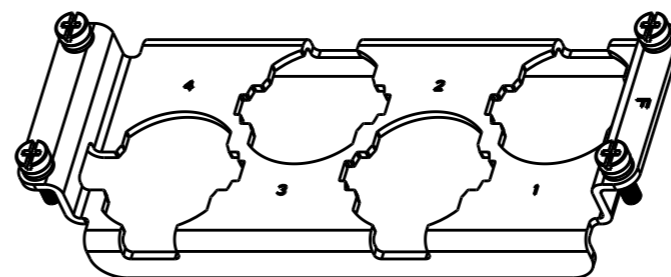
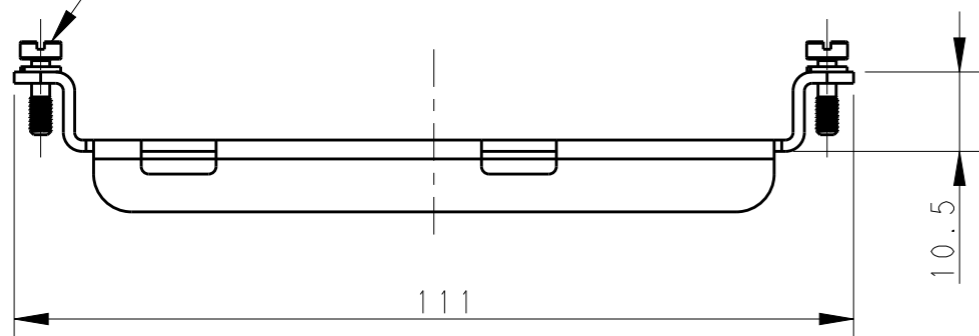

T0924049044-200

H24BPR-4P-250-F-FRAME

H24BPR-4P-250 FEMALE FRAME
 H24BPR-4P-250 母框架

PART NUMBER
 料号

PART DESCRIPTION
 描述

THIS DRAWING IS A CONTROLLED DOCUMENT.

DWN BELL SU 11APR2017
 CHK GINO YAO 11APR2017
 APVD CHRIS WANG 11APR2017

NAME H24BPR-4P-250-F-FRAME



DIMENSIONS: mm

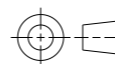

TOLERANCES UNLESS OTHERWISE SPECIFIED:
 0 PLC ±-
 1 PLC ±-
 2 PLC ±-
 3 PLC ±-
 4 PLC ±-
 ANGLES ±-

PRODUCT SPEC -
 APPLICATION SPEC -
 WEIGHT -

SIZE A3 CAGE CODE - DRAWING NO. T0924049044200 RESTRICTED TO -

MATERIAL -
 FINISH -

CUSTOMER DRAWING

SCALE 1:1 SHEET 1 OF 1 REV A