



# Revision History

Revision	Date	Description
1.0	November 2020	1 <sup>st</sup> Release

The information herein is for product information purposes. While the contents in this publication have been carefully checked; no responsibility, however, is assumed for inaccuracies. Silicon Craft Technology PLC. reserves the right to make changes to the products contained in this publication to improve design, performance, or reliability.



# Contents

<b>RA12 Development Kit Description</b> .....	<b>1</b>
<b>Revision History</b> .....	<b>2</b>
<b>Contents</b> .....	<b>3</b>
<b>List of Figures</b> .....	<b>5</b>
<b>List of Tables</b> .....	<b>6</b>
<b>1. Introduction</b> .....	<b>7</b>
<b>2. Getting Start</b> .....	<b>8</b>
2.1. System and Hardware requirements .....	8
2.2. Software setup .....	8
2.2.1. Serial Communication Configuration.....	8
2.2.2. Terminal Software (MobaXterm) .....	9
2.2.3. Download and Install MobaXterm.....	9
2.2.4. Connect PC.....	11
2.3. Hardware setup .....	14
<b>3. Command Line</b> .....	<b>15</b>
3.1. Basic Command .....	15
3.1.1. Help.....	15
3.1.2. Board Information .....	15
3.1.3. Read and Write Register .....	16
3.1.4. RF ON and OFF.....	17
3.1.5. Get Tag ID .....	17
3.2. Complex Command .....	18
3.2.1. ISO14443A Command .....	18
3.2.2. ISO14443B Command.....	18
3.2.3. ISO15693 Command .....	19
3.2.4. Card Detection.....	19
3.2.5. Mifare Command.....	21
3.2.6. Tag 2 Type Command.....	21
<b>4. Enter Mode Manually</b> .....	<b>22</b>
<b>5. Schematic</b> .....	<b>25</b>
5.1. RA12 Development Kit .....	25
5.2. MCU Part .....	26
5.3. RA12 Part .....	27
<b>6. Update Firmware</b> .....	<b>28</b>
6.1. Software.....	28
6.2. Instruction.....	28
<b>7. Test Mode</b> .....	<b>29</b>
<b>8. Product and Documentation Support</b> .....	<b>30</b>
8.1. Notation .....	30
8.2. Tools and Software .....	31



8.3. Documentation Support ..... 31

8.4. Contact Information ..... 31

**9. Legal Information..... 32**

9.1. Disclaimer ..... 32



# List of Figures

Figure 1-1 RA12 Development Kit.....	7
Figure 2-1 MobaXterm.....	9
Figure 2-2 MobaXterm Website.....	9
Figure 2-3 MobaXterm Download Page .....	10
Figure 2-4 MobaXterm Home Edition Download Page .....	10
Figure 2-5 MobaXterm Installation Window .....	11
Figure 2-6 MobaXterm Create new Session .....	12
Figure 2-7 Session Setting .....	12
Figure 2-8 Basic Serial setting.....	13
Figure 2-9 Successfully Created Serial Session.....	13
Figure 2-10 USB connection .....	14
Figure 3-1 Help Command .....	15
Figure 3-2 Hardware and firmware information .....	15
Figure 3-3 Example read register command .....	16
Figure 3-4 Example scan command .....	17
Figure 3-5 Example ISO14443A command .....	18
Figure 3-6 Example ISO15693 command.....	19
Figure 3-7 RA12 wake up behavior .....	20
Figure 3-8 Example card detection command .....	20
Figure 4-1 Step to enter card detection mode (1/2) .....	23
Figure 4-2 Step to enter card detection mode (2/2) .....	24
Figure 4-3 Step to confirm card detection mode entering and exit .....	24
Figure 6-1 STM32 ST-LINK Utility software.....	28
Figure 6-2 Window for update the firmware.....	28
Figure 7-1 RA12 Development Kit Information .....	29
Figure 8-1 Register Definition .....	30
Figure 8-2 RA12 Development Kit and reference design.....	31



# List of Tables

Table 3-1 List of read and write register .....	16
Table 3-2 List of RF command .....	17
Table 3-3 List of scan command .....	17
Table 3-4 List of ISO14443A command .....	18
Table 3-5 List of ISO14443B command.....	18
Table 3-6 List of ISO15693 command.....	19
Table 3-7 List of card detection command.....	20
Table 3-8 List of Mifare command.....	21
Table 3-9 List of Tag 2 Type command.....	21
Table 4-1 The RF threshold register setup.....	22
Table 4-2 Interrupt Enable register .....	22
Table 4-3 The Wake up time register setup .....	22
Table 4-4 CDControl register .....	22
Table 4-5 WkTimerControl register .....	23
Table 4-6 Control register .....	23
Table 8-1 Styles and Fonts for keywords.....	30



# 1. Introduction

RA12 is a single chip reader IC for 13.56MHz RFID contactless standard protocols including ISO14443A/B, ISO15693. The RA12 contains efficient power saving modes: hard power down, soft power down, standby and low-power card detection. The low-power card detection mode allows the chip to not operate at full power continuously. The chip periodically senses the external card and send interrupt signal MCU when external card is sensed.

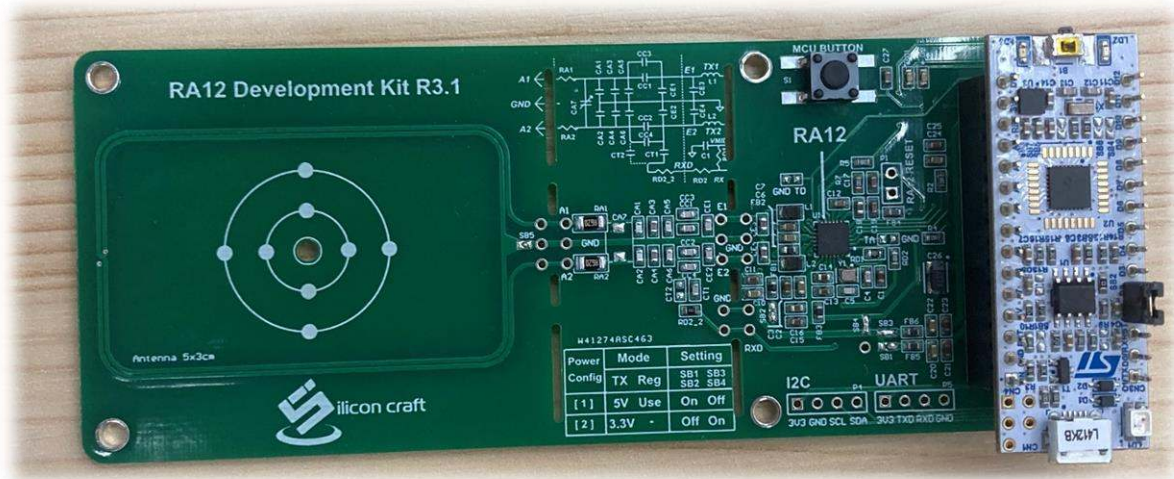

**Figure 1-1** RA12 Development Kit

Silicon Craft Technology had developed RA12 Development Kit for trial and evaluation. This development kit consists of RA12 board, standard antenna and MCU module.



## 2. Getting Start

To operate RA12 Development Kit, System environment and software installation are required per below:

### 2.1. System and Hardware requirements

- Computer : PC with USB Port
- Operating System : Window XP, Window 7, 8, 10
- Software Requirement : Hyper Terminal, Tera Term, Putty, MobaXterm, etc.
- Others : ISO14443A/B or ISO15693 Card or Tag.

### 2.2. Software setup

#### 2.2.1. Serial Communication Configuration

Serial communication configuration for RA12 Development Kit is required below:

- Serial Port : Select COM Port which match to USB to UART converter
- Baud Rate : 115200 bps
- Data : 8 bits
- Parity bit : None
- Stop bit : 1 bit





## Getting Start

### 2.2.2. Terminal Software (MobaXterm)

To interact with RA12 Development Kit, terminal is required for setup and controlling. MobaXterm is used as a terminal software to communicate with RA12 Development Kit.

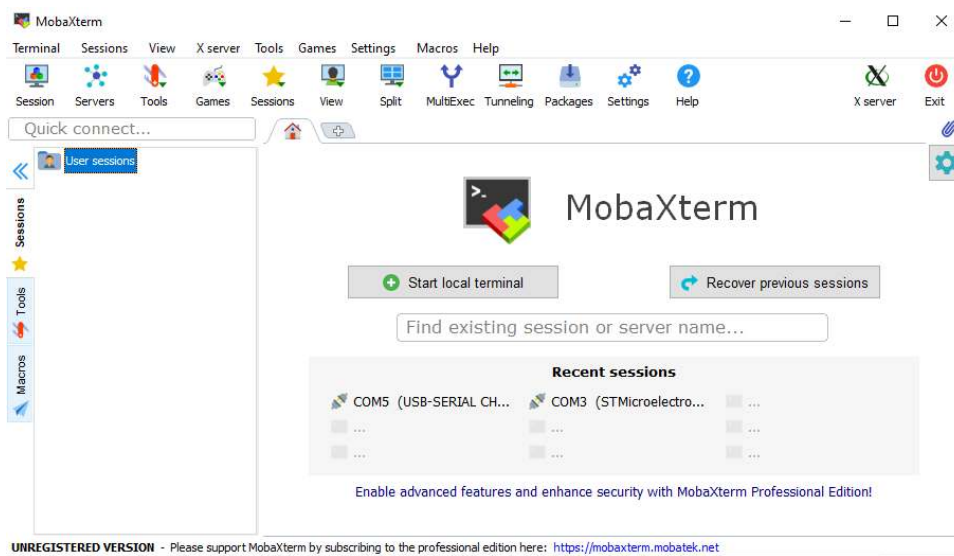

Figure 2-1 MobaXterm

### 2.2.3. Download and Install MobaXterm

1. Please download MobaXterm installation file via this link: <https://mobaxterm.mobatek.net/> then, click the tab "Download" as shown in Figure 2-2.

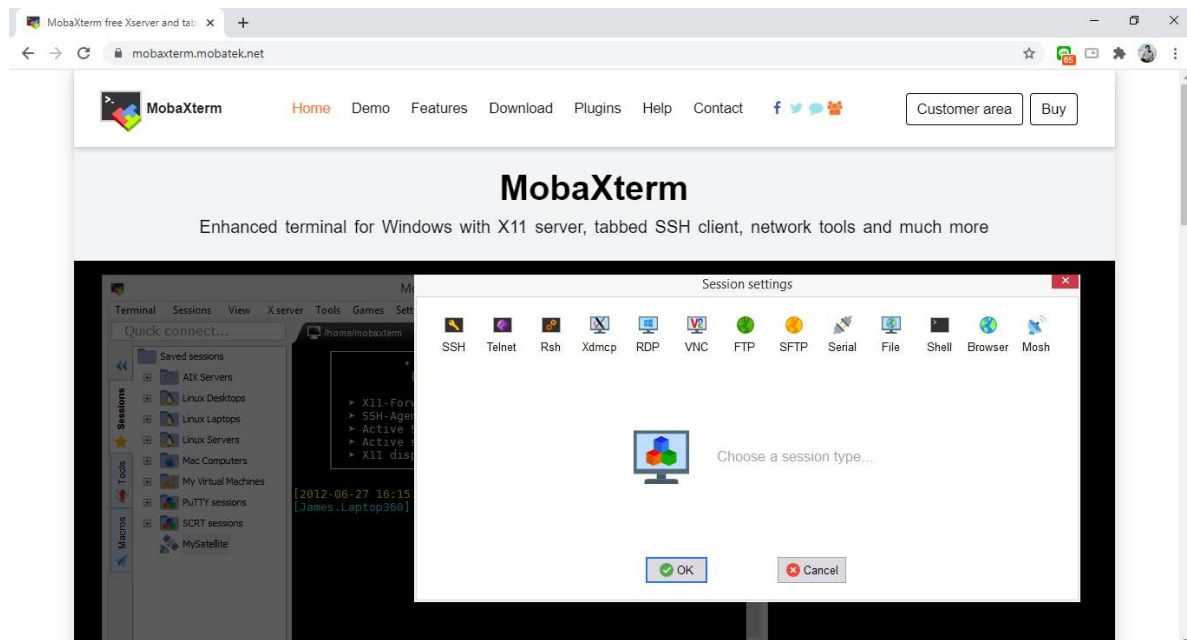
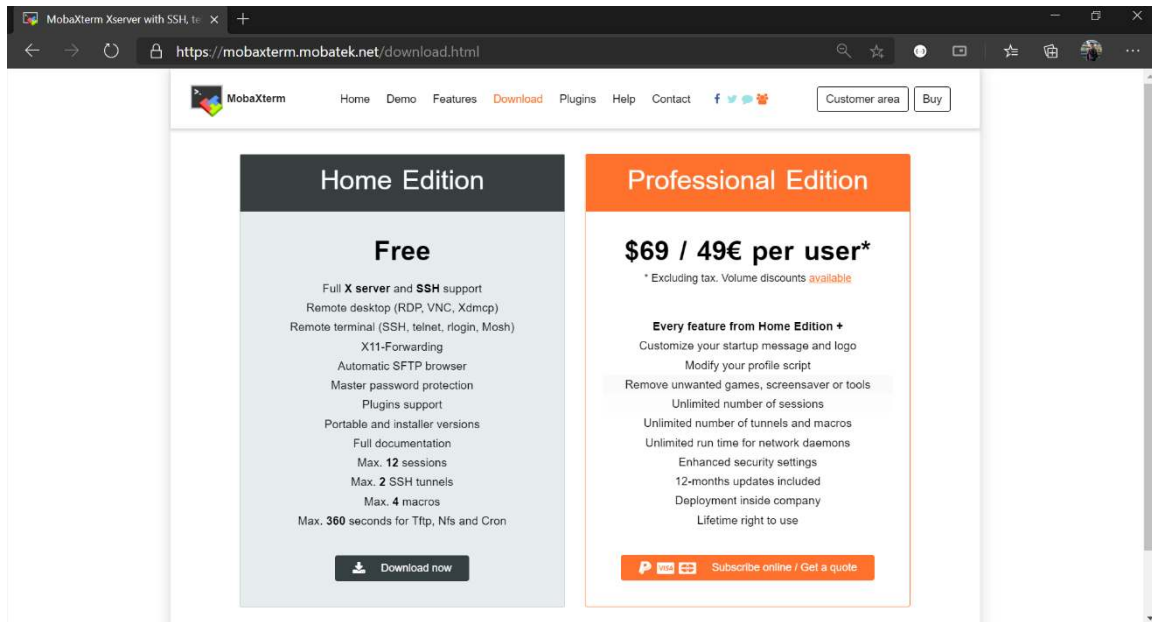

Figure 2-2 MobaXterm Website



Getting Start

- At download page, click at "Download now" to go to home edition download page as shown in **Figure 2-3**.



**Figure 2-3** MobaXterm Download Page

- At Home Edition download page, click at "MobaXterm Home Edition v20.2 (Installer Edition)" to download the installer as shown in **Figure 2-4**.

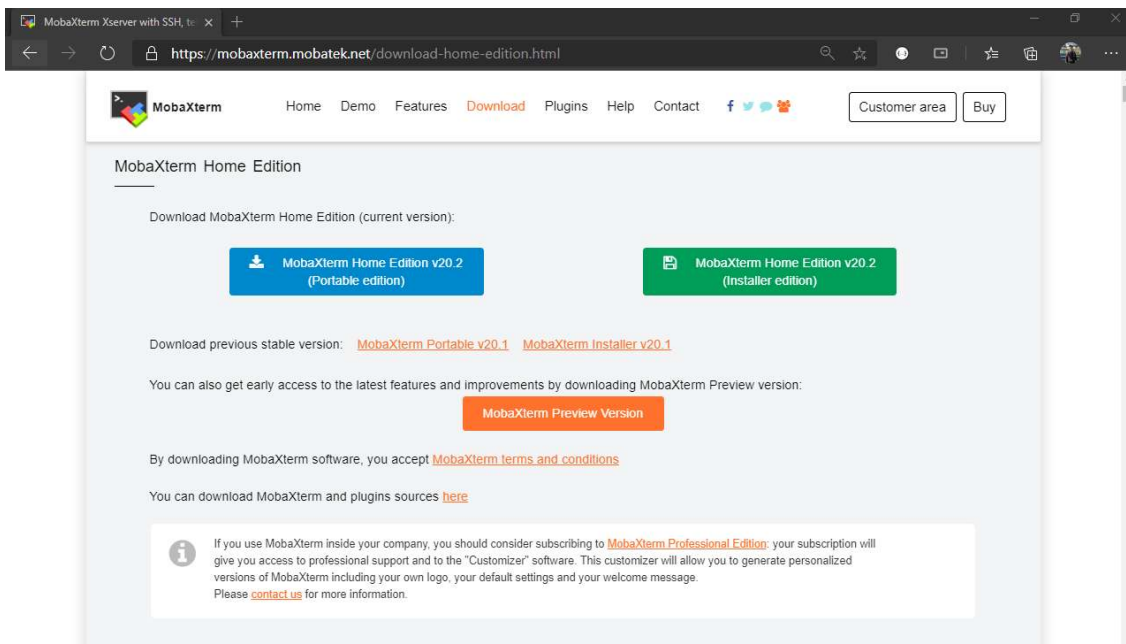

**Figure 2-4** MobaXterm Home Edition Download Page

- When the download is complete, extract the installer.
- Inside the extracted folder, double click at "MobaXterm\_installer\_20.2.msi" to begin installation.
- The installation window will pop up, click "Next" as shown in **Figure 2-5**.



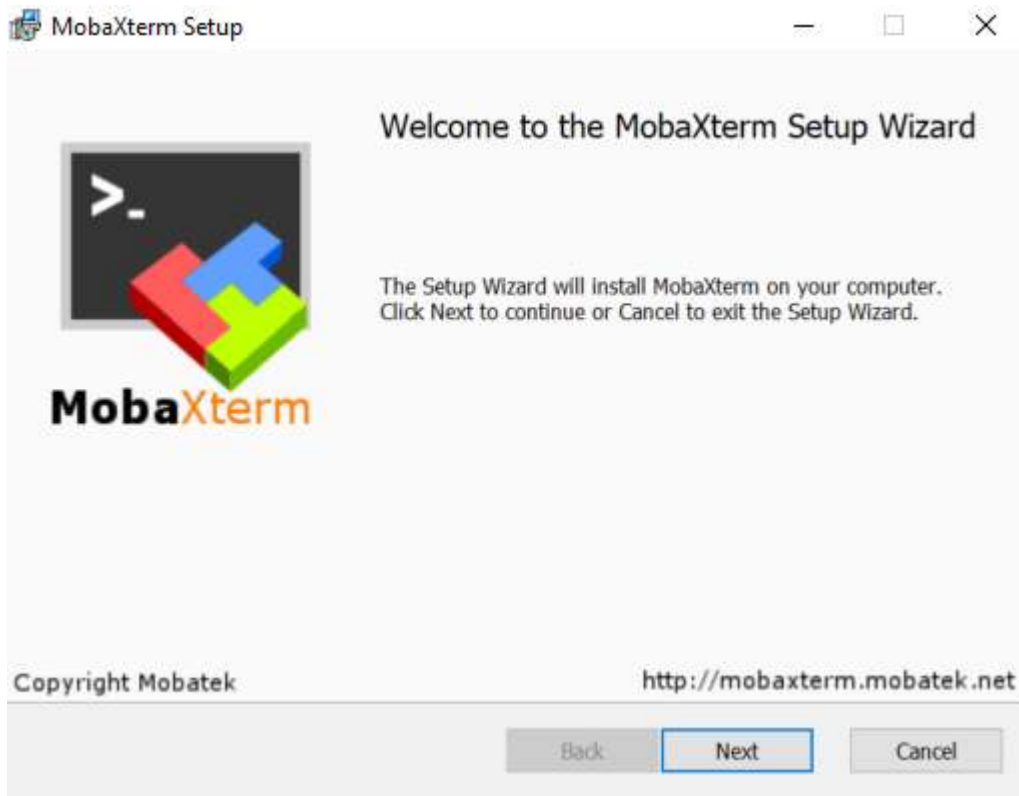

**Figure 2-5** MobaXterm Installation Window

7. At End-User License Agreement page, select the accept box and then click "Next".
8. The window will prompt for installation folder destination. Select the path to install the program then click "Next".
9. Click "Install" to begin installation.
10. Click "Finish" when the installation is completed.

#### 2.2.4. Connect PC

In order to communicate with the reader, a serial connection must be initialized. The steps below describe how to properly connect the reader with a PC.

1. Connect the reader to PC using a micro USB cable.
2. Open MobaXterm.
3. On the menu bar at the top left of the program, click at "Session" to create a new session.



## Getting Start

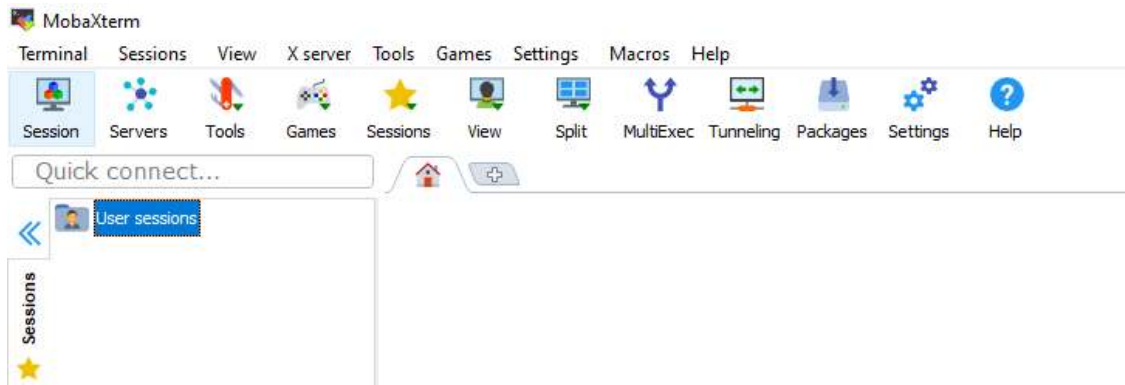

**Figure 2-6** MobaXterm Create new Session

4. The program will pop up a new window called "Session settings", click on "Serial" to set up a new serial monitor.

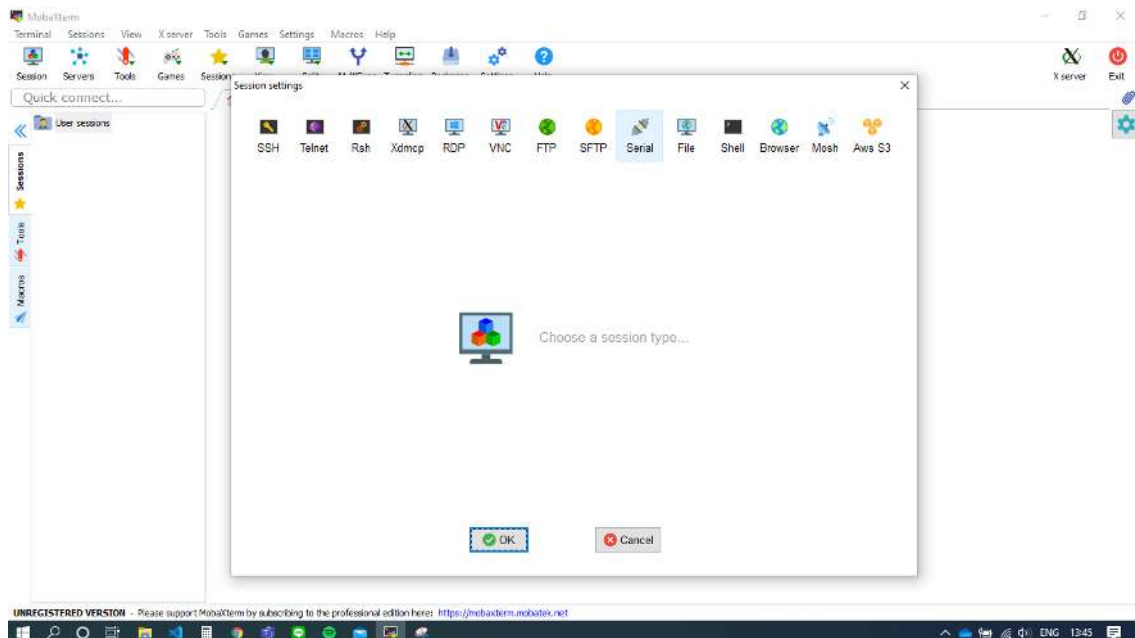

**Figure 2-7** Session Setting

5. **Figure 2-8**, under the tab "Basic Serial settings", click at the drop-down menu "Serial port" to select a port to connect. If the reader is already connected with the PC then the correspondent port number should be automatically shown up here. Otherwise, try restarting MobaXterm.
6. Click at the drop-down menu "Speed (bps)", select "115200" and then click OK to start session.



Getting Start

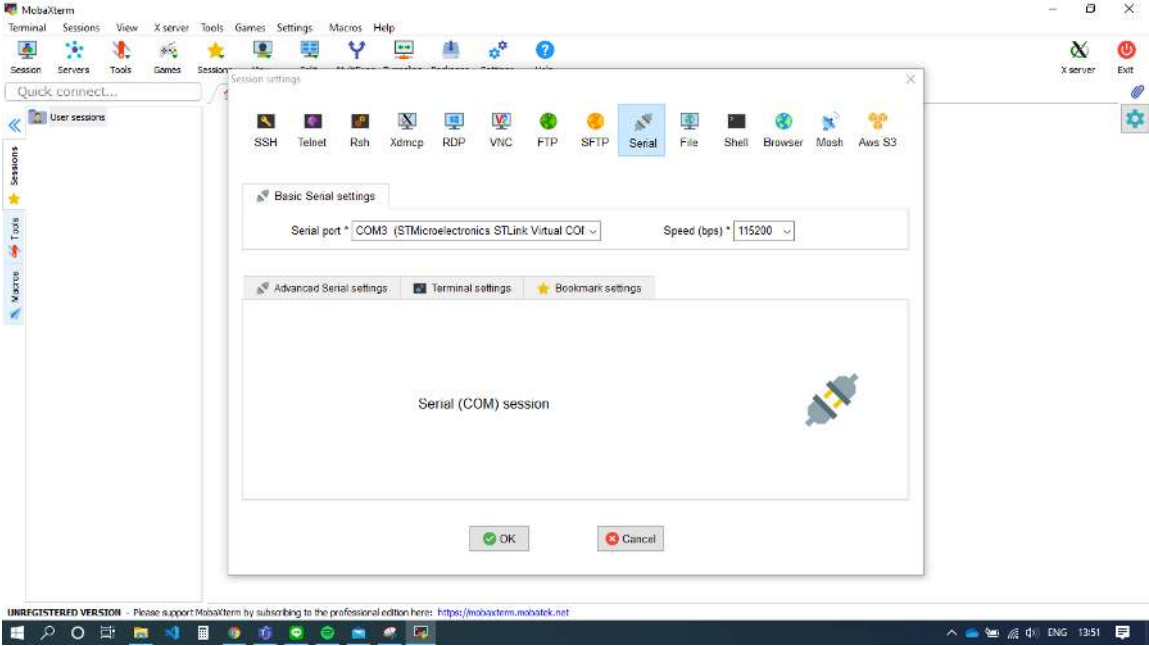

Figure 2-8 Basic Serial setting

7. Press enter to check SIC Command Line interface that start with "SIC CLI>".

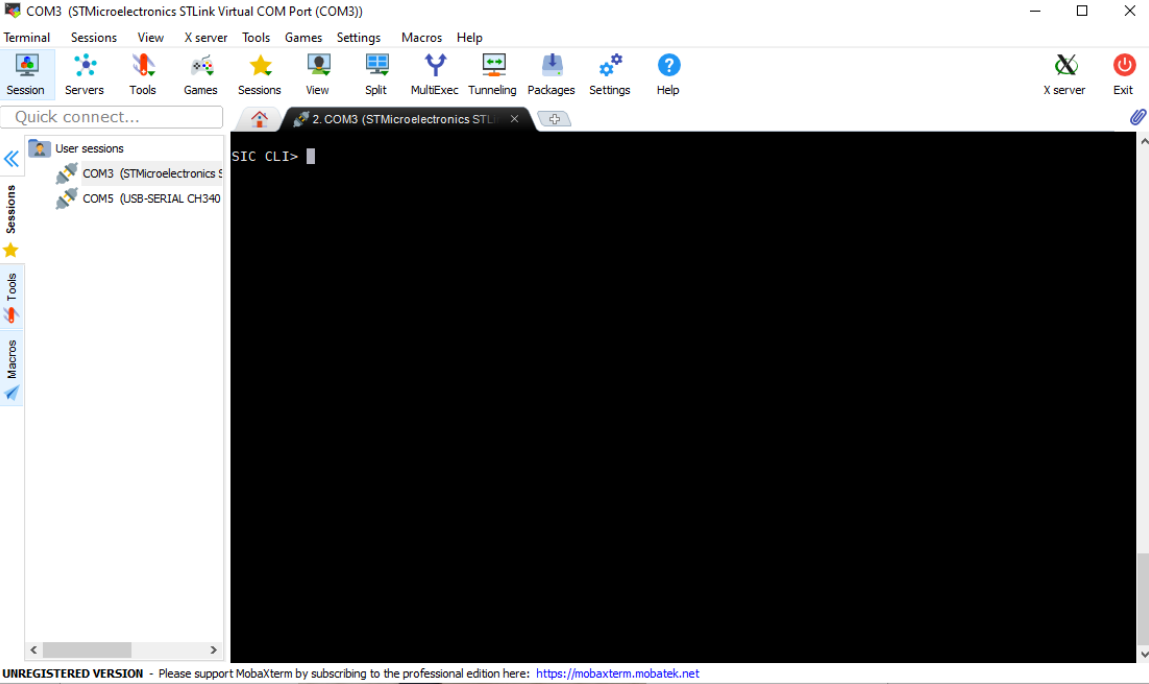

Figure 2-9 Successfully Created Serial Session



## 2.3. Hardware setup

Refer to **Figure 2-10**, please follow below steps:

1. Connect RA12 Development kit with mini USB cable to PC,
2. Open software and set up according to section [2.2](#).
3. Push RESET button on the left to initial hardware.

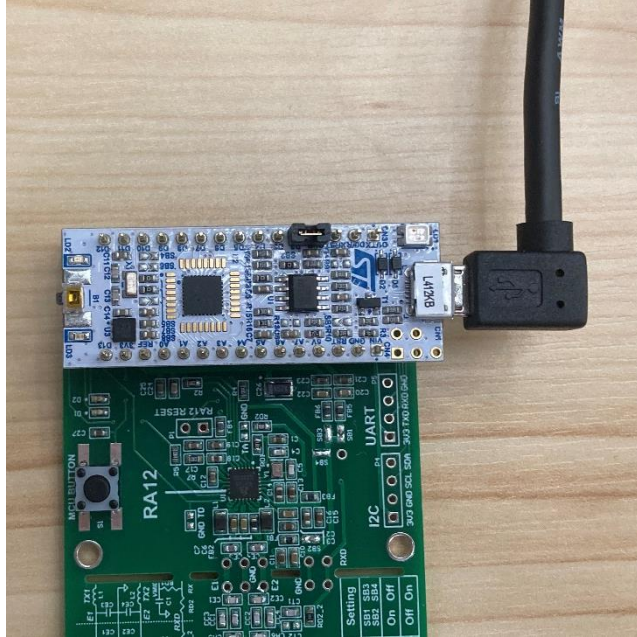

**Figure 2-10** USB connection



## 3. Command Line

RA12 Development Kit is controlled via command line through serial communication port in order to operate all functions of RA12 IC. There are 2 groups of command line as below.

1. Basic Command
2. Complex Command

### 3.1. Basic Command

Basic commands are the command for RA12 Development Kit setup reader and read UID of tag.

#### 3.1.1. Help

Help command to show all available commands for RA12 Development Kit.

```
SIC-CLI> help
CMD: help,   DESC: List available commands
CMD: info,   DESC: Print out device informations
CMD: reg,    DESC: Command for reading and writing register on RA12
CMD: rf,     DESC: Control RF field of reader
CMD: cd,     DESC: Command which relates with CD mode of RA12
CMD: a,     DESC: Use to send command for IS014443A tag type
CMD: b,     DESC: Use to send command for IS014443B tag type
CMD: v,     DESC: Use to send command for IS015693 tag type
CMD: scan,   DESC: Read Tag's UID (IS01443A, IS014443B, IS015693)
CMD: mifare,DESC: Combo command for reading/writing tag mifare type
CMD: t2t,   DESC: Combo command for reading/writing tag 2 type

Use <command> -h for showing the argument of each command
OK
```

Figure 3-1 Help Command

#### 3.1.2. Board Information

This command is for showing the information of RA12 Development Kit, MCU model and firmware version.

```
SIC-CLI> info
MCU: STM32L412KB
RA12 revision: 20 (RA12 RevB)
Purpose: This firmware is RA12 development kit version
Firmware version : 4.0.0 (Lightweight)
OK

SIC-CLI> █
```

Figure 3-2 Hardware and firmware information



### 3.1.3. Read and Write Register

This command is for reading and writing register from RA12 IC. All operation of read and write command are shown in **Table 3-1**. All inputs and display values are Hexadecimal format.

**Table 3-1** List of read and write register

Command	Input Data	Description
reg -h	-	Display all options of "reg" command.
reg -rd	<section number -s0 or -s1> <address (HEX)>	Read register value at specific section. RA12 register section address can be Section 0 (-s0) or Section 1 (-s1
	<address (HEX)>	Read register of section 0.
	-all	Read value from all registers in RA12 IC
reg -wr	<section number -s0 or -s1> <address (HEX)> <data (HEX)>	Write register value in defined address at specific section. RA12 register section address can be Section 0 (-s0) or Section 1 (-s1).
	<address (HEX)> <data (HEX)>	Write register value in defined address at section 0 only.
	-default	Reset all register value to be default.

Example of "reg" command to read specific register is shown as **Figure 3-3**.

```
SIC-CLI> reg -rd -s0 12
SEC[HEX]: 00
ADDR[HEX]: 12, VAL[HEX]:3F
OK

SIC-CLI> reg -rd 12
SEC[HEX]: 00
ADDR[HEX]: 12, VAL[HEX]:3F
OK
```

**Figure 3-3** Example read register command





### 3.1.4. RF ON and OFF

This command is to control carrier frequency from RA12 Development Kit to turn ON, turn OFF and reset RF field with fixed time (OFF RF for 6 ms and then turn ON RF).

**Table 3-2** List of RF command

Command	Input Data	Description
rf -h	-	
rf -on	-	Turn on carrier frequency of RA12 Development Kit
rf -off	-	Turn off carrier frequency of RA12 Development Kit
rf -reset	-	Turn off carrier frequency of RA12 Development Kit for 6 ms and then turn on.

### 3.1.5. Get Tag ID

This command is for scanning tag and getting tag UID of all card type: ISO14443A, ISO14443B and ISO15693. **Table 3-3** is shown operation of scan command.

**Table 3-3** List of scan command

Command	Input Data	Description
scan -h	-	Display all options of "scan" command.
scan -l	-	Use for scanning tag for ISO1443A/B or ISO15693. The scan loop will stop when the reader can read a tag.
scan -f	-	Use for scanning tag for ISO1443A/B or ISO15693 as loop scanning.

**Figure 3-4** is shown result of scan -l command when RA12 Development Kit detect a tag.

```
SIC-CLI> scan -l
Loop running start...
OK
Scanning a Tag ISO14443A
Scanning a Tag ISO14443B
Scanning a Tag ISO15693
Scanning a Tag ISO14443A
Scanning a Tag ISO14443B
Scanning a Tag ISO15693
Scanning a Tag ISO14443A
Scanning a Tag ISO14443B
Scanning a Tag ISO15693
Scanning a Tag ISO14443A
WUPA:4400
SLEEPA:
WUPA+AC+SEL:04EF0632584984
Stop loop running
OK
```

**Figure 3-4** Example scan command



## 3.2. Complex Command

### 3.2.1. ISO14443A Command

Set of command to communicate with ISO14443A tag as standard command and specific command in transparent mode which selectable with or without CRC.

**Table 3-4** List of ISO14443A command

Command	Input Data	Description
a -h	-	Display all options of ISO14443A command
a -setup	-	Set up RA12 register for ISO14443A standard
a -wf	<register> <value>	
a -wf -h		Display how to use a -wf command
a -wupa	-	ISO14443A wake up command
a -reqa	-	ISO14443A request command
a -hlta	-	ISO14443A halt command
a -anticoll	<level 1- 3>	ISO14443A Anti-collision command with cascade level 1 = 0x93, 2 = 0x95, 3 = 0x97
a -sel	<level 1- 3>	ISO14443A Select command with cascade level 1 = 0x93, 2 = 0x95, 3 = 0x97
a -getuid	-	Combo command to get tag UID
a -trans -crc	<data in HEX>	Transparent command with CRC
a -trans -nocrc	<data in HEX>	Transparent command without CRC

```
SIC-CLI> a -getuid
04EF0632584984
OK
```

**Figure 3-5** Example ISO14443A command

### 3.2.2. ISO14443B Command

Set of command to communicate with ISO14443B tag as standard command and specific command in transparent mode which selectable with or without CRC.

**Table 3-5** List of ISO14443B command

Command	Input Data	Description
b -h		Display all options of ISO14443B command
b -setup		Set up RA12 register for ISO14443B standard
b -wf	<register> <value>	
b -wf -h		Display how to use b -wf command
b -reqb		ISO14443B request command
b -wupb		ISO14443B wake up command
b -attrib	<PUP1 4 bytes>	ISO14443B ATTRIB command
b -halt	<PUP1 4 bytes>	ISO14443B halt command
b -trans -crc	<data in HEX>	Transparent command with CRC
b -trans -nocrc	<data in HEX>	Transparent command without CRC



### 3.2.3. ISO15693 Command

Set of command to communicate with ISO15693 tag as standard command and specific command in transparent mode which selectable with or without CRC.

**Table 3-6** List of ISO15693 command

Command	Input Data	Description
v -h		Display all options of ISO15693 command
v -setup		Set up RA12 register for ISO15693 standard
v -wf	<register> <value>	
v -wf -h		Display how to use v -wf command
v -inv1	<AFI, 00 for all families>	ISO15693 Inventory 1 slot command
v -inv16		ISO15693 Inventory 16 slot command
v -quiet	<PUP1 4 bytes>	ISO15693 quiet command
v -rd	<address in HEX> <UID>	Read ISO15693 tag memory
v -wr	<address in HEX> <data in HEX> <UID>	Write ISO15693 tag memory
v -trans -crc	<data in HEX>	Transparent command with CRC
v -trans -nocrc	<data in HEX>	Transparent command without CRC

```
SIC-CLI> v -setup
OK

SIC-CLI> v -inv1 00
E004025004C98132
OK
```

**Figure 3-6** Example ISO15693 command

### 3.2.4. Card Detection

RA12 includes card detection feature which periodically transmits short RF pulse to check the existing tag near antenna. In case the card has been detected by RA12, it will send interrupt signal to the MCU to proceed the following action. This operation scheme significantly reduces power consumption of the overall system.

RA12 Development Kit supports 2 wake up behaviors during low power card detection mode as shown in **Figure 3-7** including

- a) RA12 remains in sleeping after IRQ of card detection is set to high.
- b) RA12 wake up after IRQ of card detection is set to high.



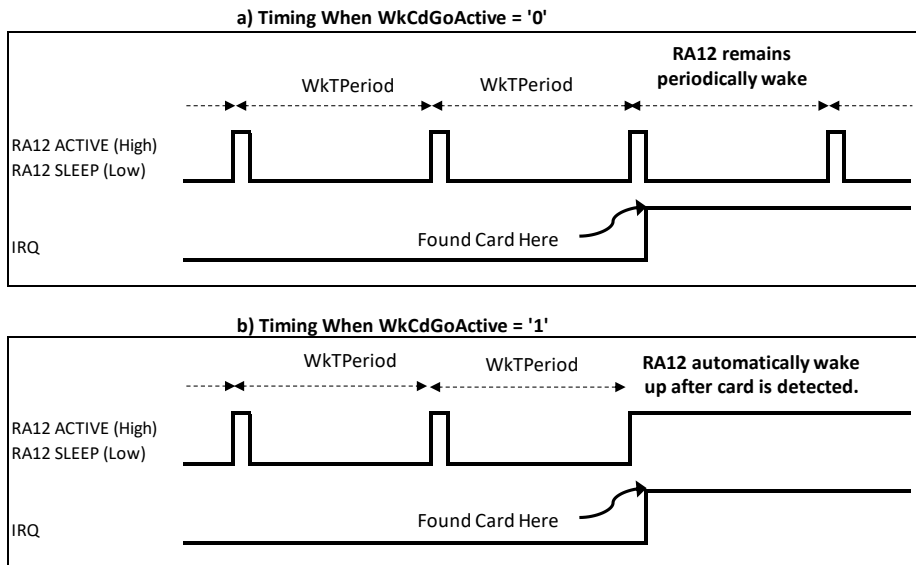

Figure 3-7 RA12 wake up behavior

Set of command to set up and evaluate card detection mode of RA12 Development Kit is shown in Table 3-7.

Table 3-7 List of card detection command

Command	Input Data	Description
cd -h	-	Display all options of cd command (card detection command).
cd -c	-	Enter RA12 Development Kit to cd mode with "WkCdGoActive = 1". RA12 wake up after the detection of RF field changes and MCU will try to get tag UID automatically after receive interrupt signal from RA12.
cd -w	-	Enter RA12 Development Kit to cd mode with "WkCdGoActive = 0". RA12 only send interrupt signal to MCU after found RF field change. MCU will wait for user key input to continue.
cd -cal	-	Calibrate threshold of card detection mode.
cd -th	<1-5>	Set threshold level from 1 to 5
cd -lpmcu	<-sleep, -stop, -idle>	Set up low power of MCU when RA12 enter to card detection mode
cd -wkuptime	<100, 200, 500, 1000>	Set up wake up timer period as ms

```
SIC-CLI> cd -cal
Please don't place any tag.
Calibrating...

ADC_I[HEX]: 26, VAL[HEX]:A5
ADC_Q[HEX]: 27, VAL[HEX]:B3
Tunning completed
OK
```

Figure 3-8 Example card detection command



### 3.2.5. Mifare Command

Specific command for Mifare card is available as **Table 3-8** both of read and write with encryption key.

**Table 3-8** List of Mifare command

Command	Input Data	Description
mifare -h	-	Display all options of mifare command
mifare -cread	<ka, kb> <KeyValue> <Block no. in DEC>	Mifare card read command with selectable key type. This command is require encryption key and destination block to read data.
mifare -cwrite	<ka, kb> <KeyValue> <Block no. in DEC> <DataValue in HEX>	Mifare card write command with selectable key type. This command is require encryption key and destination block to read data.

### 3.2.6 Tag 2 Type Command

**Table 3-9** is shown standard command for NFC Tag 2 Type as read 16 bytes data and write 4 bytes data per block.

**Table 3-9** List of Tag 2 Type command

Command	Input Data	Description
t2t -h	-	Display all options of t2t command (Tag 2 Type)
t2t -rd	<block address HEX>	Read block command, response data is 16 bytes
t2t -wr	<block address HEX> <data in HEX>	Write block command with data 4 bytes/block



## 4. Enter Mode Manually

Instead of entering RA12 card detection mode using Card detection Mode command explained in section 3.2.3., manual step to enter card detection mode is also available. The following section explain how to enter card detection mode manually which will lead to more understanding in RA12 card detection operation.

1. Calibrate threshold of card detection mode: There are 2 options to set up RF detection threshold.
  - a. Use "cd -cal" command to reading RF field during no card near antenna as explain in section 3.2.4.
  - b. Manually set threshold value into registers in the following table.

**Table 4-1** The RF threshold register setup

Register Name	Section	Address	Length	Definitions
CDThreshold_LL	0	0x34	8 bits	Low side threshold for I phase
CDThreshold_LH	0	0x35	8 bits	High side threshold for I phase
CDThreshold_QL	0	0x36	8 bits	Low side threshold for Q phase
CDThreshold_QH	0	0x37	8 bits	High side threshold for Q phase

2. Setup interrupt event when card is detected at register **Interrupt Enable** by set bit **SetIEN** and **CDIEN** to 1b.

**Table 4-2** Interrupt Enable register

Register Name	Bit 7	Bit 6	Bit 5	Bit 4	Bit 3	Bit 2	Bit 1	Bit 0
<b>Interrupt Enable (0x06)</b>	<b>SetIEN</b>	<b>CDIEN</b>						

3. Setup wake up period: In card detection mode, RA12 wakes up periodically base on 2 registers, **WkTPrescaler** and **WkTReloadValue**.

**Table 4-3** The Wake up time register setup

Register Name	Section	Address	Length	Definitions
<b>WkTPrescaler</b>	0	0x2D	4 bits (3:0)	Wake up prescaler register
<b>WkTReloadValue</b>	0	0x2E	8 bits	Wake up reload register

4. Setup RA12 to wake up even during Field Detection (i.e. other mobile phone or HF reader come close to antenna) by set **WkIgnoreFD** to 1b.

**Table 4-4** CDControl register

Register Name	Bit 7	Bit 6	Bit 5	Bit 4	Bit 3	Bit 2	Bit 1	Bit 0
<b>CDControl (0x31)</b>		<b>WkIgnoreFD</b>						



5. Prepare RA12 Wake Up timer counting operation at **WkTimerControl**
  - a. Start timer by set **WkTStartNow** to 1b.
  - b. Set wake up auto restart by set **WkAutoRestart** to 1b.

**Table 4-5** WkTimerControl register

Register Name	Bit 7	Bit 6	Bit 5	Bit 4	Bit 3	Bit 2	Bit 1	Bit 0
<b>WkTimerControl (0x2D)</b>	<b>WkTStartNow</b>			<b>WkAutoRestart</b>				

6. Setup RA12 to enter wake up card detection mode by set **WkUpCD** to 1b.

**Table 4-6** Control register

Register Name	Bit 7	Bit 6	Bit 5	Bit 4	Bit 3	Bit 2	Bit 1	Bit 0
<b>Control (0x09)</b>		<b>WkUpCD</b>						

Error! Reference source not found. and Error! Reference source not found. are shown step of input to enter card detection mode.

```

SIC CLI> write -p0 34 D0
PAGE[HEX]: 00
ADDR[HEX]: 34, WR[HEX]:D0
OK

SIC CLI> write -p0 35 FF
PAGE[HEX]: 00
ADDR[HEX]: 35, WR[HEX]:FF
OK

SIC CLI> write -p0 36 20
PAGE[HEX]: 00
ADDR[HEX]: 36, WR[HEX]:20
OK

SIC CLI> write -p0 37 40
PAGE[HEX]: 00
ADDR[HEX]: 37, WR[HEX]:40
OK

SIC CLI> write -p0 06 C0
PAGE[HEX]: 00
ADDR[HEX]: 06, WR[HEX]:C0
OK

SIC CLI> write -p0 2D 09
PAGE[HEX]: 00
ADDR[HEX]: 2D, WR[HEX]:09
OK

SIC CLI> write -p0 2E 20
PAGE[HEX]: 00
ADDR[HEX]: 2E, WR[HEX]:20
OK

SIC CLI> write -p0 31 40
PAGE[HEX]: 00
ADDR[HEX]: 31, WR[HEX]:40
OK

SIC CLI> write -p0 2D 98
PAGE[HEX]: 00
  
```

1) Calibrate threshold of card detection mode

2) Setup interrupt event

3) Setup wake up period

4) Set RA12 to wake up even during Field Detection

**Figure 4-1** Step to enter card detection mode (1/2)



Enter Mode Manually

```

SIC CLI> write -p0 31 40
PAGE[HEX]: 00
ADDR[HEX]: 31, WR[HEX]:40
OK

SIC CLI> write -p0 2D 98
PAGE[HEX]: 00
ADDR[HEX]: 2D, WR[HEX]:98
OK

SIC CLI> read -p0 2D
PAGE[HEX]: 00
ADDR[HEX]: 2D, VAL[HEX]:38
OK

SIC CLI> read -p0 09
PAGE[HEX]: 00
ADDR[HEX]: 09, VAL[HEX]:00
OK

SIC CLI> write -p0 09 40
PAGE[HEX]: 00
ADDR[HEX]: 09, WR[HEX]:40
OK

SIC CLI> read -p0 09
PAGE[HEX]: 00
ADDR[HEX]: 09, VAL[HEX]:50
OK
    
```

5) Prepare RA12 Wake Up timer counting operation

6) Set RA12 to enter wake up card detection mode

Figure 4-2 Step to enter card detection mode (2/2)

Error! Reference source not found. is shown step of input to check card detection entering and exit

```

SIC CLI> read -p0 09
PAGE[HEX]: 00
ADDR[HEX]: 09, VAL[HEX]:50
OK

SIC CLI> read -p0 26
PAGE[HEX]: 00
ADDR[HEX]: 26, VAL[HEX]:F3
OK

SIC CLI> read -p0 09
PAGE[HEX]: 00
ADDR[HEX]: 09, VAL[HEX]:50
OK

SIC CLI> read -p0 26
PAGE[HEX]: 00
ADDR[HEX]: 26, VAL[HEX]:F1
OK

SIC CLI> read -p0 09
PAGE[HEX]: 00
ADDR[HEX]: 09, VAL[HEX]:50
OK

SIC CLI> read -p0 26
PAGE[HEX]: 00
ADDR[HEX]: 26, VAL[HEX]:4C
OK

SIC CLI> read -p0 09
PAGE[HEX]: 00
ADDR[HEX]: 09, VAL[HEX]:00
OK
    
```

Remain in Power Down Mode (0x50)

Remain in Power Down Mode (0x50)

Remain in Power Down Mode (0x50)

Insert card to RA12 Development Kit here

Card detected / Exit in Power Down Mode (0x00)

Figure 4-3 Step to confirm card detection mode entering and exit





# 5. Schematic

## 5.1. RA12 Development Kit

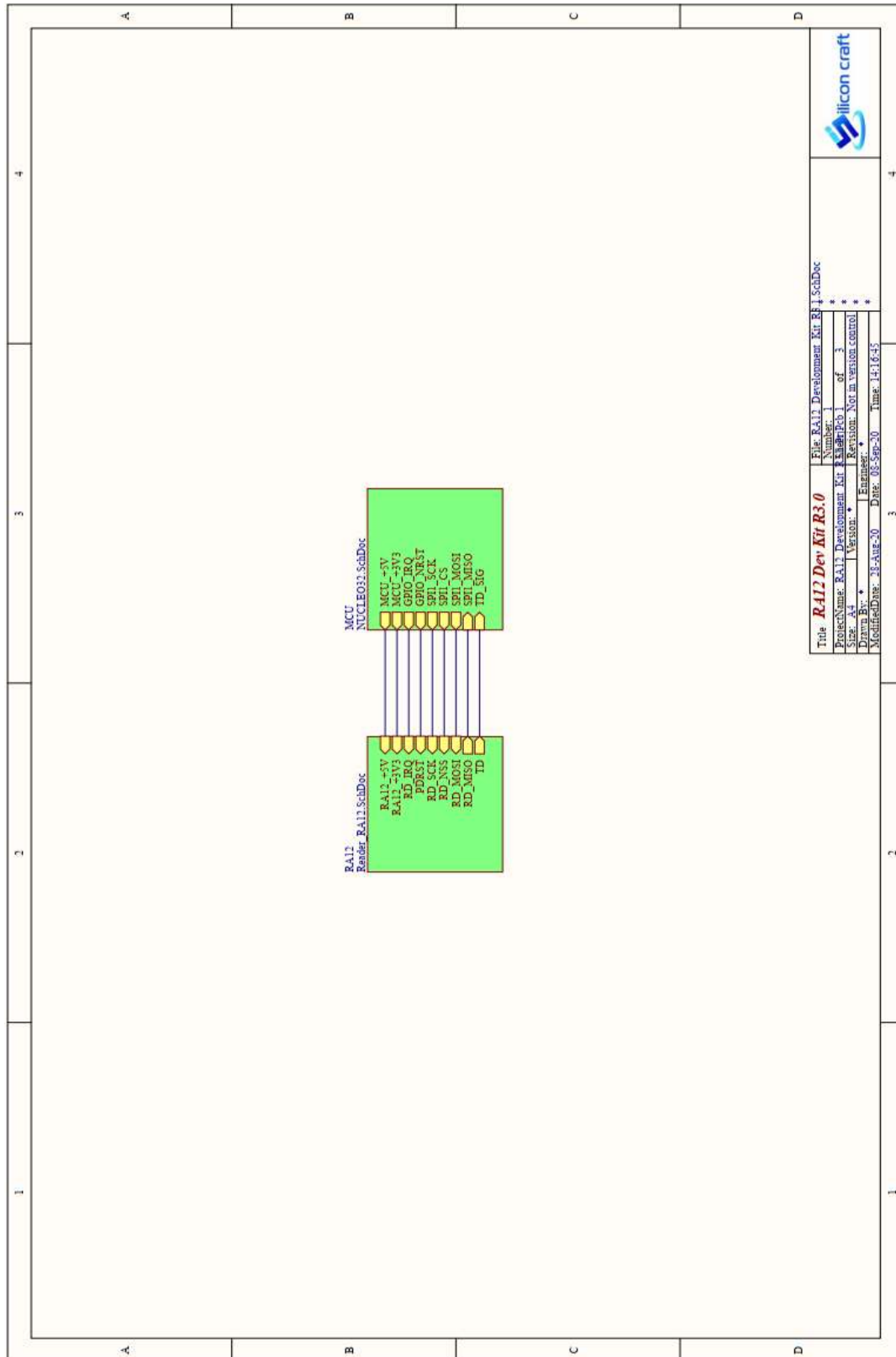

### 5.2. MCU Part

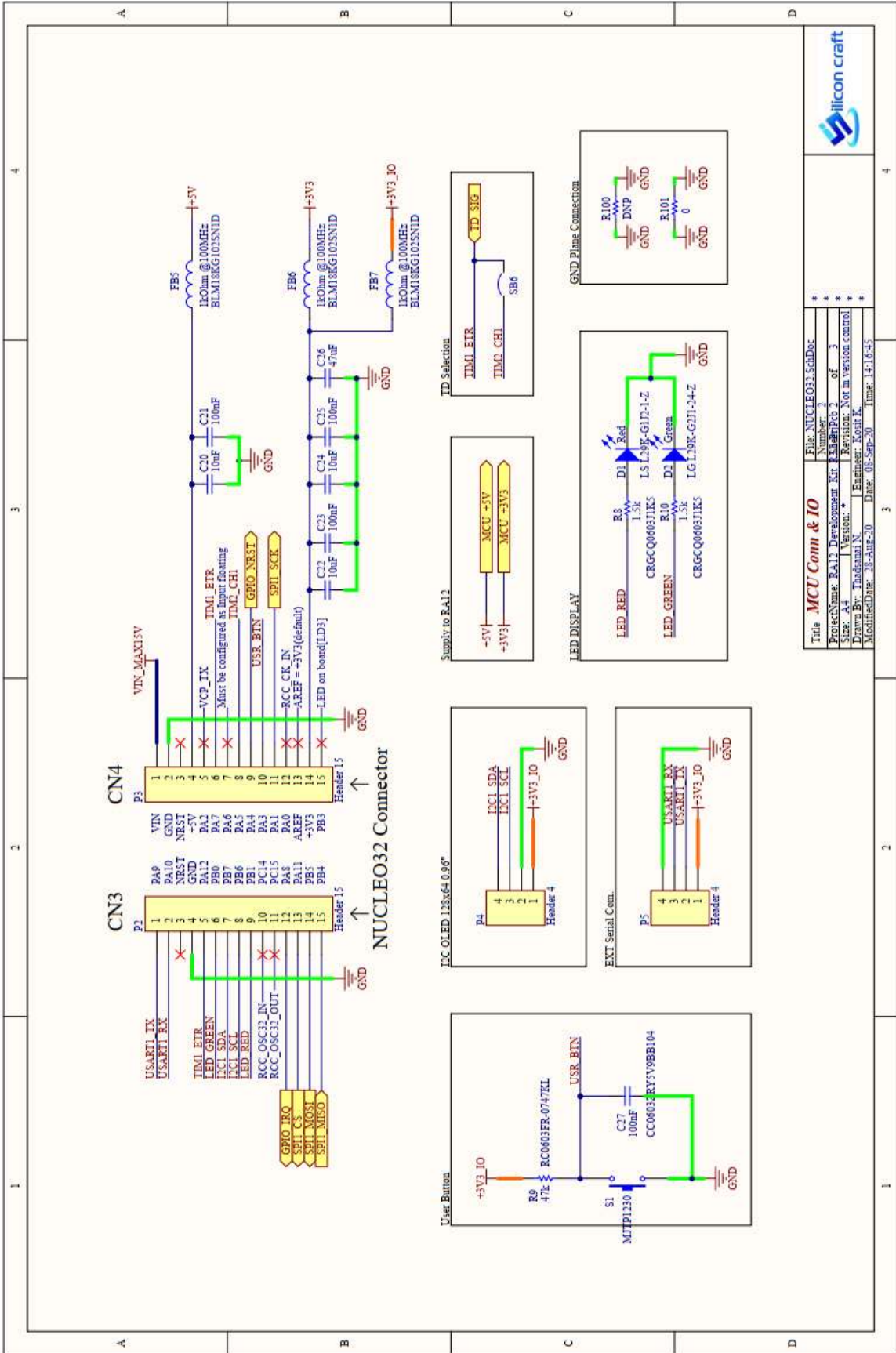

Title		File: NUCLEO32_SchDoc	
ProjectName:	RA12 Development Kit	Number:	3
Size:	A4	Revision:	Not in version control.
Drawn By:	Thaddeus N. Engineer: Kshit K.	Modified Date:	31-Aug-20 Date: 05-Sep-20 Time: 14:16:45



### 5.3. RA12 Part

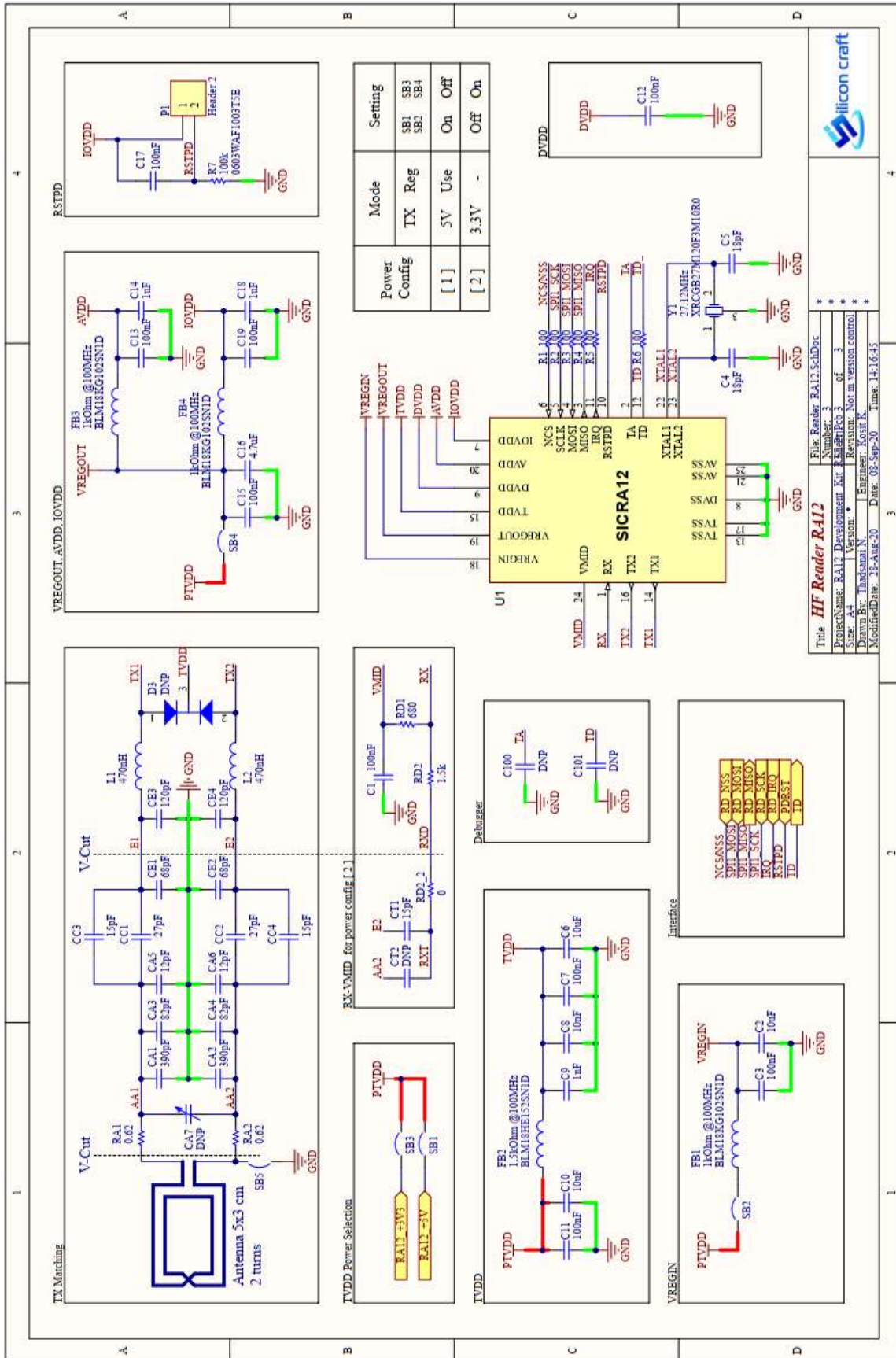

## 6. Update Firmware

### 6.1. Software

To update new firmware of RA12 Development Kit, STM32 ST-LINK Utility is required. Software installer can download via this link: <https://www.st.com/en/development-tools/stsw-link004.html>

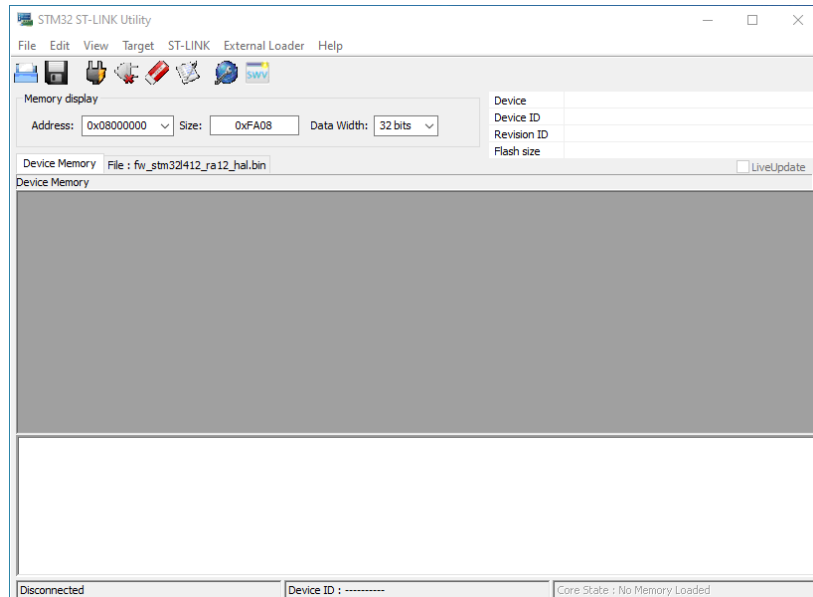

Figure 6-1 STM32 ST-LINK Utility software

### 6.2. Instruction

1. Open STM32 ST-LINK Utility software
2. Connect RA12 Development kit to PC
3. Click "Target" and then select "Connect"
4. Click "Target" and then select "Program and Verify"
5. Select target file (.bin, .hex, s19)
6. Click "Start" to update the new firmware to target MCU.

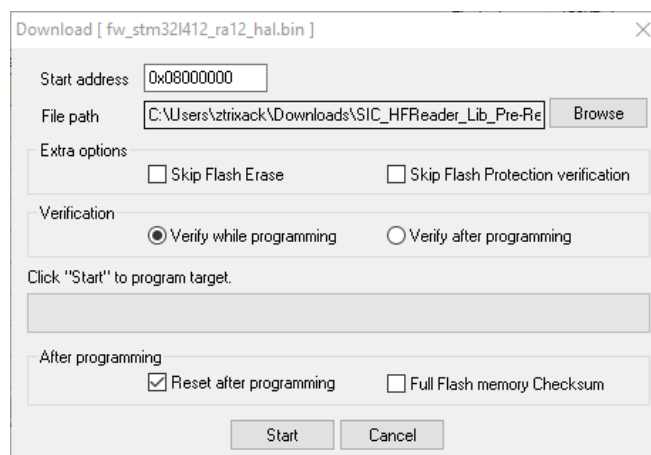
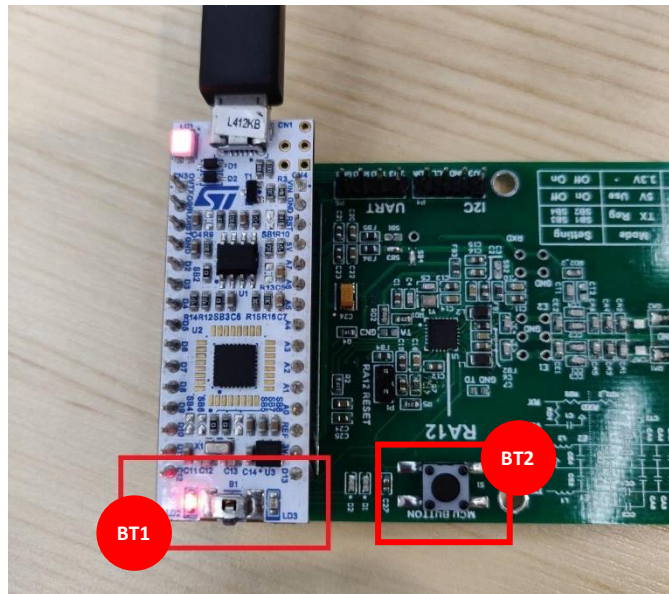

Figure 6-2 Window for update the firmware



## 7. Test Mode

To enter test mode, user must activate user button (BT2) while RA12 Development Kit is in initial process or after push reset button (BT1) within 5 seconds.



There are 3 steps to check RA12 Development functional per below:

1. Board Information:

RA12 Development Kit Information will be shown after user button is pushed and successful entering to test mode refer to **Figure 7-1**.

```

STM32L412KB with RA12 CLI Start
*** ----- RA12 Test Mode ----- ***

* please record the product serial number.(HEX) *
MASKSET: A8
PRODUCTION PARAMETER: 00
REVISION: 20
SERIAL NUMBER: 0032002D 384D5007 20373543
    
```

**Figure 7-1** RA12 Development Kit Information

2. Card Detection:

RA12 Development Kit will automatically run card detection calibration. Reading card is required to exit card detection mode test.

3. Reading Standard Tag:

All standard tag should be placed and read UID out with this sequence: ISO14443A, ISO14443B and ISO15693.



## 8. Product and Documentation Support

For more information of the SIC products, tools, and support that are available to help your development, please visit [www.sic.co.th](http://www.sic.co.th)

### 8.1. Notation

The register definition is shown in the **Figure 8-1**.

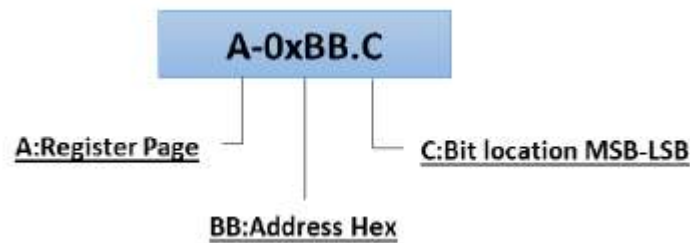

**Figure 8-1** Register Definition

#### Styles and Fonts for key words

This part defines styles and fonts used for the key words throughout this document. The key words are names of signal, register and pin. The styles, fonts and their indications are shown in **Table 8-1**.

**Table 8-1** Styles and Fonts for keywords

Symbol	Indication
<i>Signal</i>	Signal name
<b>Register</b>	Register name or Bit name
pin <b>RX</b>	Pin name
<i>"State of Operation"</i>	State of operation
<b>Command</b>	Command name in register 0x01 sector 0

To refer to a register address, a hexadecimal number proceeding with "0x" is used, for example 0x05 refer to a register address 0x05.

To refer to a bit located in a register address, a symbol "." following by a number reflecting the bit location starting from 0 to 7 is used. For example, 0x05.2 refers to bit 2, MSB, in the register address 0x05.

To refer to a set of consecutive bits located in a register address, a format ".[MSB:LSB]" is used after a register address. For example, a value of 0x05.[3:0] refers to bit 3, 2, 1 and 0 in the register 0x05.

To refer to a binary value in some registers, the letter "b" is placed at the end of binary number. For an example "0101b".

To refer to logic level, the number in single quote '1' and '0' are used to refer to binary logic level.



## 8.2. Tools and Software

- Development Kit and Reference Design

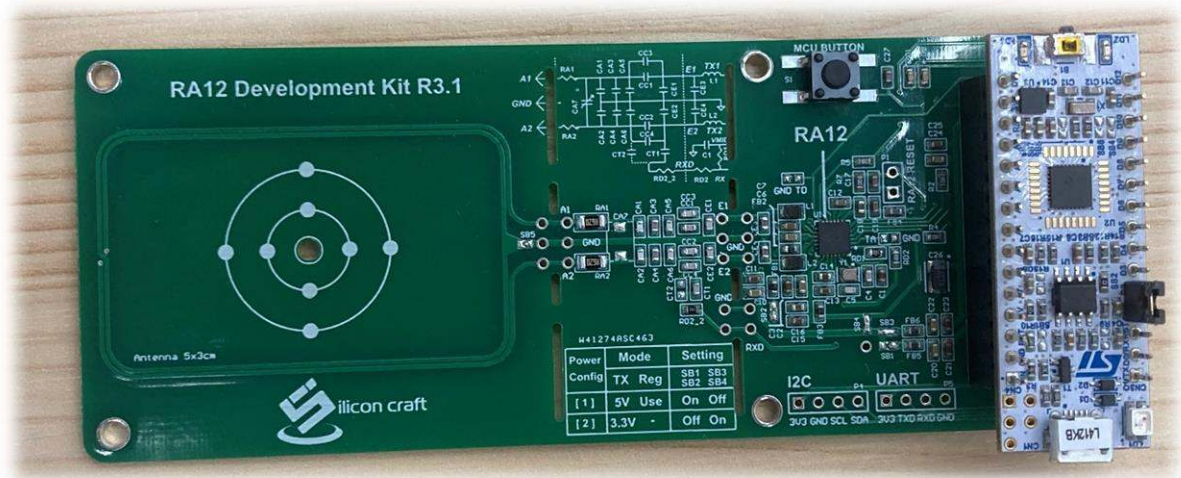

Figure 8-2 RA12 Development Kit and reference design

## 8.3. Documentation Support

Datasheet and Factsheet

- [RA12 Data Sheet](#)

- [RA12 Fact Sheet](#)

Application Note

- [RA12 Card Detection mode operation](#)

## 8.4. Contact Information

Tel: +66 2 589 9991

Fax: +66 2 589 8881

Email: [info@sic.co.th](mailto:info@sic.co.th)



## 9. Legal Information

### 9.1. Disclaimer

- The information described herein is subject to change without notice.
- Although the IC contains a static electricity protection circuit, static electricity or voltage that exceeds the limit of the protection circuit should not be applied.
- SIC assumes no responsibility for how this IC is used in products created using this IC or for the specifications of that product, nor does SIC. Assume any responsibility for any infringement of patents or copyrights by-products that include this IC either in Thailand or in other countries.
- SIC is not responsible for any problems caused by circuits or diagrams described herein whose related industrial properties, patents, or other rights belong to third parties. The application circuit examples explain typical applications of the products and do not guarantee the success of any specific mass-production design.
- The use of the information described herein for other purposes and/or reproduction or copying without the express permission of SIC is strictly prohibited.
- The products described herein cannot be used as part of any device or equipment affecting the human body, such as exercise equipment, medical equipment, security systems, gas equipment, or any apparatus installed in airplanes and other vehicles, without prior written permission of SIC.
- Although SIC exerts the greatest possible effort to ensure high quality and reliability, the failure or malfunction of semiconductor products may occur. The user of these products should, therefore, give thorough consideration to safety design, including redundancy, fire-prevention measures, and malfunction prevention, to prevent any accidents, fires, or community damage that may ensue.

