



# STEVAL-TLL006V2

New high-power LED driver demo board for single flash with I<sup>2</sup>C interface based on STCF06 (with motherboard based on  $\mu$ PSD)

Data brief

## Features

- Buck-boost DC-DC converter
- Drives one power LED up to:
  - 1.5 A between 3.5 V to 5.5 V
  - 1.3 A between 3.0 V to 5.5 V
  - 1 A between 2.7 V to 5.5 V
- Efficiency up to 85%
- LED current control
- 1.8 MHz fixed frequency PWM
- Full I<sup>2</sup>C control
- Motherboard based on  $\mu$ PSD used as USB bridge
- RoHS compliant

## Description

The STEVAL-TLL006V2 demonstration board implements a flash LED driver using the STCF06 device, which is a buck-boost current mode converter with an I<sup>2</sup>C interface.

As technology for external components has greatly improved, in this new version “V2” it was possible to shrink the original application and maintain the same level of performance or similar.

The flash LED driver STCF06 has a high operational frequency (1.8 MHz) which allows the use of small external components.

The STEVAL-TLL006V2 is designed for driving a single LED with a forward voltage range from 2.7 to 5 V.

For easy connection to the PC, a motherboard is supplied based on  $\mu$ PSD which is used as a bridge.

The STCF06 motherboard uses a USB human interface device class to communicate with the PC. It is not necessary to install any driver, if the operating system is able to enumerate USB human interface devices.



Connect the motherboard to the PC through the USB cable (AB type). Wait until the computer enumerates the control board and displays the message that new hardware has been found and is ready to use. It is then possible to run the data packet creator application by pressing the “Connect board” button.

# 1 Schematic

Figure 1. Circuit schematic

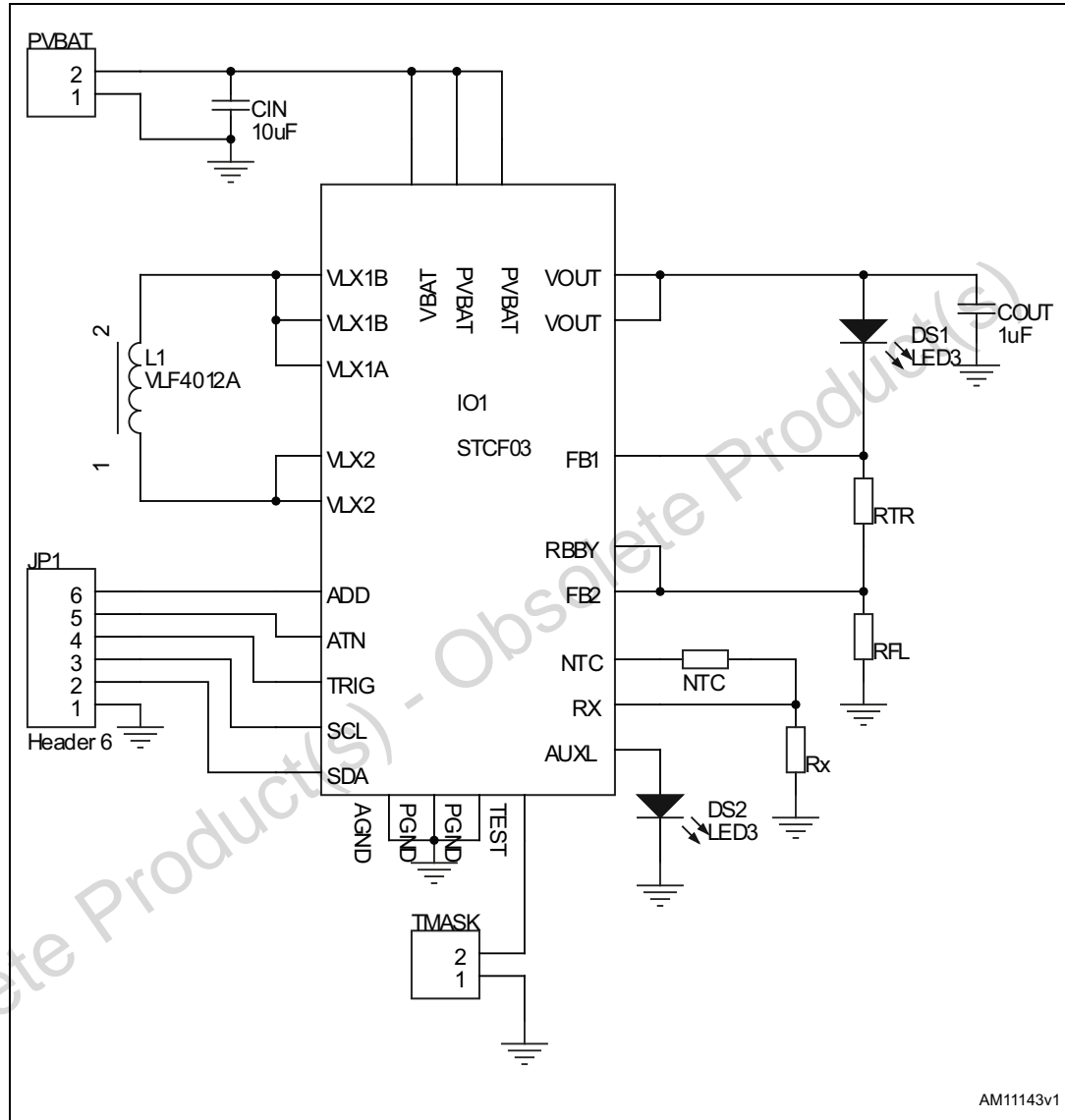

AM11143v1

## 2 Revision history

Table 1. Document revision history

Date	Revision	Changes
28-Mar-2012	1	Initial release.

Obsolete Product(s) - Obsolete Product(s)

**Please Read Carefully:**

Information in this document is provided solely in connection with ST products. STMicroelectronics NV and its subsidiaries ("ST") reserve the right to make changes, corrections, modifications or improvements, to this document, and the products and services described herein at any time, without notice.

All ST products are sold pursuant to ST's terms and conditions of sale.

Purchasers are solely responsible for the choice, selection and use of the ST products and services described herein, and ST assumes no liability whatsoever relating to the choice, selection or use of the ST products and services described herein.

No license, express or implied, by estoppel or otherwise, to any intellectual property rights is granted under this document. If any part of this document refers to any third party products or services it shall not be deemed a license grant by ST for the use of such third party products or services, or any intellectual property contained therein or considered as a warranty covering the use in any manner whatsoever of such third party products or services or any intellectual property contained therein.

**UNLESS OTHERWISE SET FORTH IN ST'S TERMS AND CONDITIONS OF SALE ST DISCLAIMS ANY EXPRESS OR IMPLIED WARRANTY WITH RESPECT TO THE USE AND/OR SALE OF ST PRODUCTS INCLUDING WITHOUT LIMITATION IMPLIED WARRANTIES OF MERCHANTABILITY, FITNESS FOR A PARTICULAR PURPOSE (AND THEIR EQUIVALENTS UNDER THE LAWS OF ANY JURISDICTION), OR INFRINGEMENT OF ANY PATENT, COPYRIGHT OR OTHER INTELLECTUAL PROPERTY RIGHT.**

**UNLESS EXPRESSLY APPROVED IN WRITING BY TWO AUTHORIZED ST REPRESENTATIVES, ST PRODUCTS ARE NOT RECOMMENDED, AUTHORIZED OR WARRANTED FOR USE IN MILITARY, AIR CRAFT, SPACE, LIFE SAVING, OR LIFE SUSTAINING APPLICATIONS, NOR IN PRODUCTS OR SYSTEMS WHERE FAILURE OR MALFUNCTION MAY RESULT IN PERSONAL INJURY, DEATH, OR SEVERE PROPERTY OR ENVIRONMENTAL DAMAGE. ST PRODUCTS WHICH ARE NOT SPECIFIED AS "AUTOMOTIVE GRADE" MAY ONLY BE USED IN AUTOMOTIVE APPLICATIONS AT USER'S OWN RISK.**

Resale of ST products with provisions different from the statements and/or technical features set forth in this document shall immediately void any warranty granted by ST for the ST product or service described herein and shall not create or extend in any manner whatsoever, any liability of ST.

ST and the ST logo are trademarks or registered trademarks of ST in various countries.

Information in this document supersedes and replaces all information previously supplied.

The ST logo is a registered trademark of STMicroelectronics. All other names are the property of their respective owners.

© 2012 STMicroelectronics - All rights reserved

STMicroelectronics group of companies

Australia - Belgium - Brazil - Canada - China - Czech Republic - Finland - France - Germany - Hong Kong - India - Israel - Italy - Japan - Malaysia - Malta - Morocco - Philippines - Singapore - Spain - Sweden - Switzerland - United Kingdom - United States of America

[www.st.com](http://www.st.com)