

NCX2202

Low voltage comparator; open-drain output

Rev. 5.1 — 21 November 2019

Product data sheet

1. General description

The NCX2202 is a single low voltage, low power, comparator with open-drain output.

The NCX2202 has a very low supply current of 6 μA and is guaranteed to operate at a low voltage of 1.3 V and is fully operational up to 5.5 V. These characteristics make the device convenient for use in both 3.0 V and 5.0 V systems.

2. Features and benefits

- Wide supply voltage range from 1.3 V to 5.5 V (functional operating range)
- Rail-to-rail input/output performance
- Very low supply current of 6 μA (typical)
- Very low-power consumption
- No phase inversion with overdriven input signals
- Internal hysteresis
- Propagation delay of 0.8 μs (typical)
- ESD protection:
 - ◆ HBM JESD22-A114F Class 1C exceeds 1500 V
 - ◆ CDM JESD22-C101E exceeds 1000 V
- Multiple package options
- Specified from $-40\text{ }^{\circ}\text{C}$ to $+85\text{ }^{\circ}\text{C}$

3. Applications

- Cellular telephones
- Alarm and security systems
- Personal Digital assistants



4. Ordering information

Table 1. Ordering information

Type number	Topside marking ^[1]	Package		
		Name	Description	Version
NCX2202GW	qa	TSSOP5	plastic thin shrink small outline package; 5 leads; body width 1.25 mm	SOT353-1
NCX2202GM	qa	XSON6	plastic extremely thin small outline package; no leads; 6 terminals; body 1 × 1.45 × 0.5 mm	SOT886
NCX2202GM	X2	XSON6	plastic extremely thin small outline package; no leads; 6 terminals; body 1 × 1.45 × 0.5 mm; requires SSB	SOT886

[1] The pin 1 indicator is located on the lower left corner of the device, below the marking code.

4.1 Ordering options

Table 2. Ordering options

Type number	Orderable part number	Package	Packing method	Minimum order quantity	Temperature
NCX2202GW	NCX2202GW,125	TSSOP5	REEL 7" Q3/T4 NDP	3000	T _{amb} = -40 °C to +85 °C
NCX2202GM	NCX2202GM,115 ^[1]	XSON6	REEL 7" Q1/T1 NDP	5000	T _{amb} = -40 °C to +85 °C
NCX2202GM	NCX2202GMZ	XSON6	REEL 7" Q1/T1 NDP SSB ^[2]	5000	T _{amb} = -40 °C to +85 °C

[1] Will go EOL - migrate to new leadframe orderable part number NCX2202GMZ.

[2] This packing method uses a Static Shielding Bag (SSB) solution. Material is to be kept in the sealed bag between uses.

5. Functional diagram

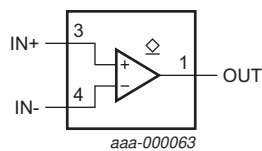

Fig 1. Logic symbol

6. Pinning information

6.1 Pinning

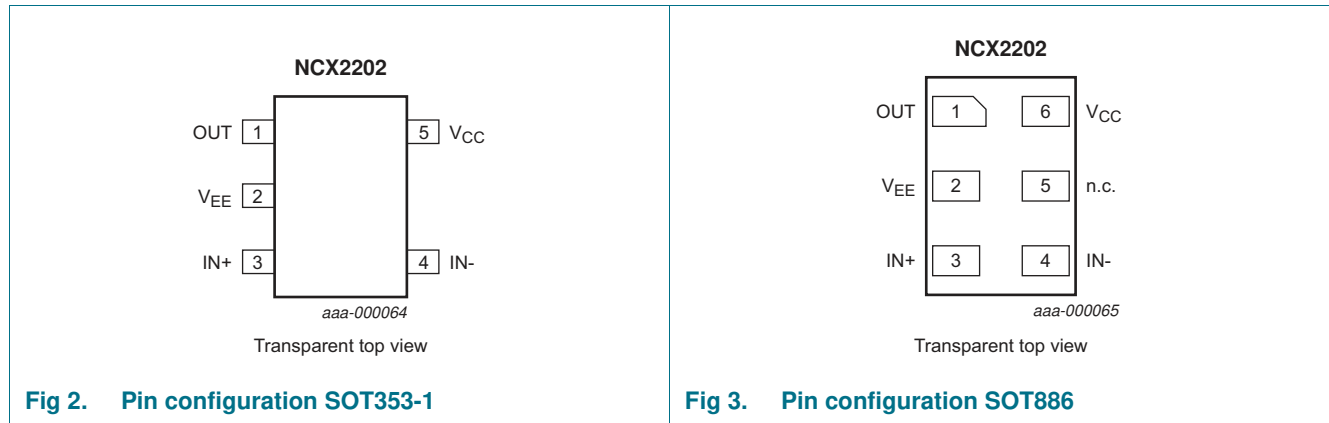

Fig 2. Pin configuration SOT353-1

Fig 3. Pin configuration SOT886

6.2 Pin description

Table 3. Pin description

Symbol	Pin		Description
	SOT353-1	SOT886	
OUT	1	1	comparator output (open-drain)
V _{EE}	2	2	supply voltage
IN+	3	3	comparator input (positive)
IN-	4	4	comparator input (negative)
n.c.	-	5	not connected
V _{CC}	5	6	supply voltage

7. Limiting values

Table 4. Limiting values

In accordance with the Absolute Maximum Rating System (IEC 60134). Voltages are referenced to V_{EE}.

Symbol	Parameter	Conditions	Min	Max	Unit
V _{CC}	supply voltage		-	7.0	V
V _I	input voltage	IN-, IN+ inputs	-0.5	V _{CC} + 0.5	V
V _O	output voltage		V _{EE} - 0.5	7.0	V
t _{sc(o)}	output short-circuit time		[1]	indefinite	s
T _{j(max)}	maximum junction temperature		-	+150	°C
T _{stg}	storage temperature		-65	+150	°C
P _{tot}	total power dissipation	T _{amb} = -40 °C to +85 °C	-	250	mW

[1] The maximum total power dissipation must not be exceeded.

8. Recommended operating conditions

Table 5. Recommended operating conditions

Symbol	Parameter	Conditions	Min	Typ	Max	Unit
V_{CC}	supply voltage	V_{CC} to V_{EE}				
		full spec operating range	1.6	-	5.5	V
		functional operating range	1.3	-	5.5	V
V_I	input voltage		V_{EE}	-	V_{CC}	V
V_O	output voltage		V_{EE}	-	5.5	V
T_{amb}	ambient temperature		-40	-	+85	°C

9. Static characteristics

Table 6. Static characteristics

At recommended operating conditions. $V_{CC} = 1.6\text{ V to }5.5\text{ V}$, $V_{EE} = 0\text{ V}$; $V_{CM} = 0.5V_{CC}$ unless otherwise specified.

Symbol	Parameter	Conditions	25 °C			-40 °C to +85 °C		Unit
			Min	Typ	Max	Min	Max	
V_H	hysteresis voltage		6	9	13	-	-	mV
		$V_{CC} = 1.3\text{ V}$	-	20	-	-	-	mV
$V_{I(\text{offset})}$	offset input voltage	[1] $V_{CC} = 1.3\text{ V}$	-30	0.5	+30	-30	+30	mV
		[1] $V_{CC} = 1.3\text{ V}$	-	3	-	-	-	mV
V_{OL}	LOW-level output voltage	$I_O = 0.5\text{ mA}$; $V_{CC} = 1.3\text{ V}$	-	0.05	-	-	-	V
		$I_O = 0.5\text{ mA}$; $V_{CC} = 1.6\text{ V}$	-	0.04	-	-	0.25	V
		$I_O = 3\text{ mA}$; $V_{CC} = 3.0\text{ V}$	-	0.14	-	-	0.3	V
		$I_O = 5\text{ mA}$; $V_{CC} = 5.5\text{ V}$	-	0.20	-	-	0.3	V
I_{OZ}	OFF-state output current	$I_{N-} = V_{EE}$; $I_{N+} = V_{CC}$; $V_O = 5.5\text{ V}$	-	3	-	-	-	nA
V_{CM}	common-mode voltage	$V_{CC} = 1.3\text{ V to }5.5\text{ V}$	-	V_{EE} to V_{CC}	-	-	-	V
I_{OS}	output short-circuit current	$V_{CC} = 5.5\text{ V}$; $V_O = V_{CC}$	-	68	-	-	-	mA
CMRR	common-mode rejection ratio	$\Delta V_{CM} = V_{CC}$	-	70	-	-	-	dB
PSRR	power supply rejection ratio	$\Delta V_{CC} = 1.95\text{ V}$	45	80	-	-	-	dB
I_{IB}	input bias current		-	1.0	-	-	-	pA
I_{CC}	supply current		-	6.0	-	-	9.0	μA

[1] Differential input switching level is guaranteed at the minimum or maximum offset voltage, minus or plus half the maximum hysteresis voltage.

10. Dynamic characteristics

Table 7. Dynamic characteristics

Voltages are referenced to V_{EE} ($V_{EE} = 0\text{ V}$); $V_{CC} = 1.6\text{ V to }5.5\text{ V}$; $V_{CM} = 0.5V_{CC}$ unless otherwise specified.

Symbol	Parameter	Conditions	25 °C			Unit	
			Min	Typ	Max		
t_{pd}	propagation delay	20 mV overdrive; $C_L = 15\text{ pF}$	[1]	-	0.8	-	μs
t_t	transition time	HIGH to LOW; $V_{CC} = 5.5\text{ V}$; $C_L = 50\text{ pF}$	[2]	-	10	-	ns

[1] t_{pd} is the same as t_{PLZ} and t_{PZL} ; t_{PLZ} is the time that the output is disabled.

[2] Input signal: 1 kHz, square wave signal with 10 ns edge rate.

11. Graphs

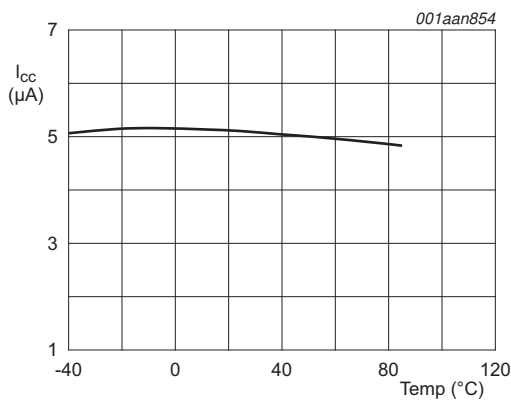

$V_{CC} = 5.0\text{ V}$.

Fig 4. Supply current versus temperature

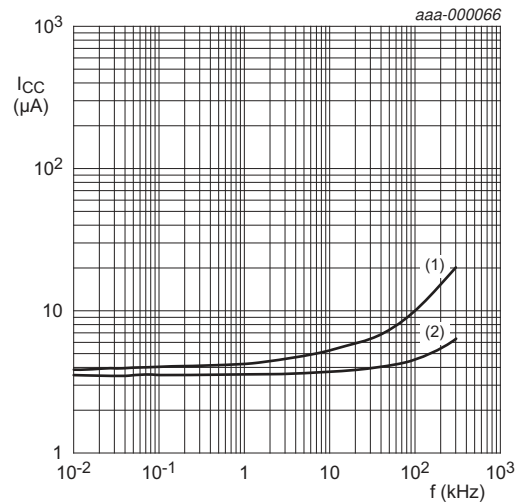

$T_{amb} = 25\text{ °C}$; $C_L = 15\text{ pF}$.

(1) $V_{CC} = 5.0\text{ V}$.

(2) $V_{CC} = 2.7\text{ V}$.

Fig 5. Supply current versus output transition frequency

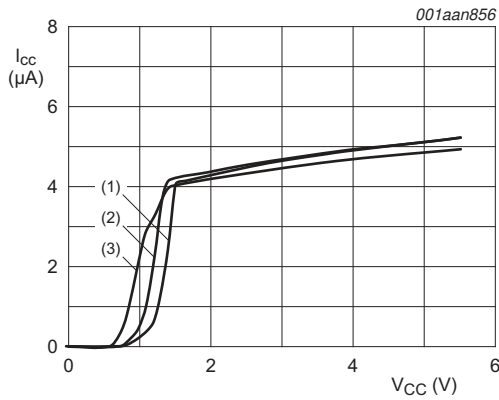

- (1) $T_{amb} = -40\text{ }^{\circ}\text{C}$.
- (2) $T_{amb} = 25\text{ }^{\circ}\text{C}$.
- (3) $T_{amb} = 85\text{ }^{\circ}\text{C}$.

Fig 6. Supply current versus supply voltage

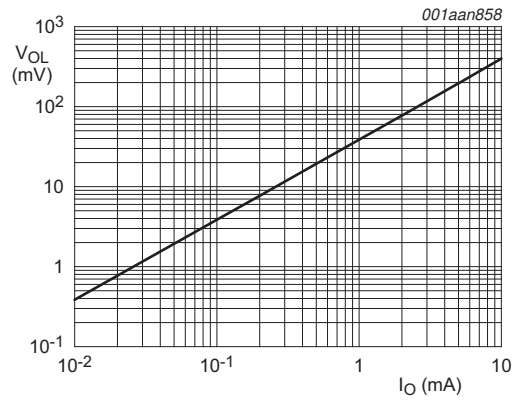

$T_{amb} = 25\text{ }^{\circ}\text{C}$.
 $V_{CC} = 5.0\text{ V}$.

Fig 7. LOW-level output voltage versus output current

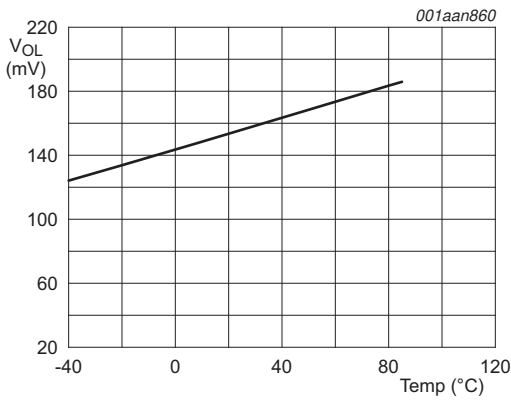

$I_O = 4.0\text{ mA}$.
 $V_{CC} = 5.0\text{ V}$.

Fig 8. LOW-level output voltage versus temperature

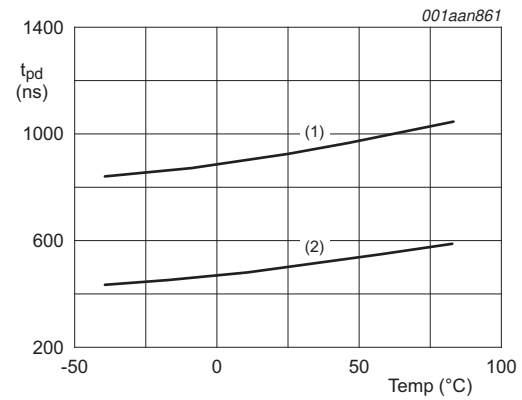

$V_{CC} = 5.0\text{ V}$; input overdrive = 50 mV.
 (1) t_{PLZ} .
 (2) t_{PZL} .

Fig 9. Propagation delay versus temperature

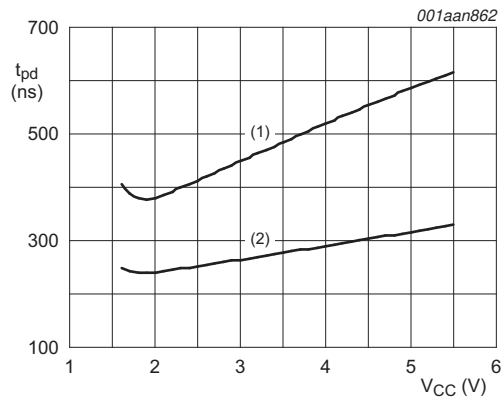

T_{amb} = 25 °C; input overdrive = 100 mV.

(1) t_{PLZ}.

(2) t_{PZL}.

Fig 10. Propagation delay versus supply voltage.

12. Application information

12.1 Operating description

The NCX2202 is a single low voltage, low power, comparator with open-drain output. This device is designed for use with a pull-up resistor to define the output switching levels. This device consumes only 6 μA of supply current while achieving a typical propagation delay of 0.8 μs at a 20 mV input overdrive. [Figure 9](#) and [Figure 10](#) show propagation delay with various input overdrives. This comparator is guaranteed to operate at a low voltage of 1.3 V up to 5.5 V. The common-mode input voltage range extends 0.1 V beyond the upper and lower rail without phase inversion or other adverse effects. This device has a typical internal hysteresis of 9.0 mV. This allows for greater noise immunity and clean output switching.

12.2 Output stage

The NCX2202 has an N-channel output stage that has capability of sinking the output to V_{EE} with a load ranging up to 5.0 mA. See [Figure 11](#)

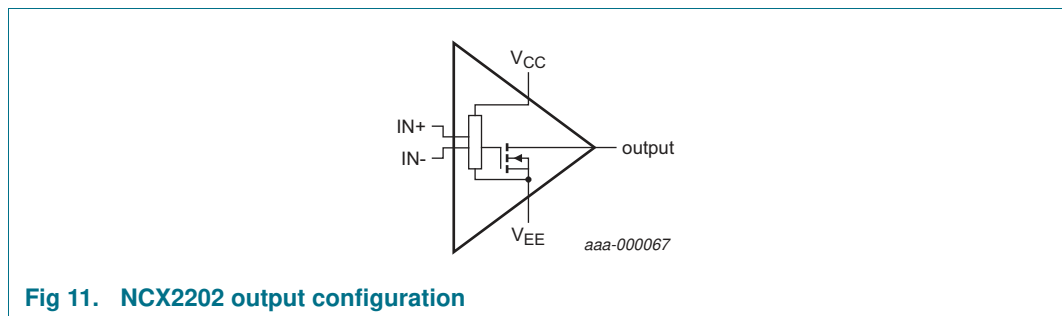

Fig 11. NCX2202 output configuration

12.3 Zero-crossing detector

[Figure 12](#) shows the NCX2202 configured as a zero-crossing detector.

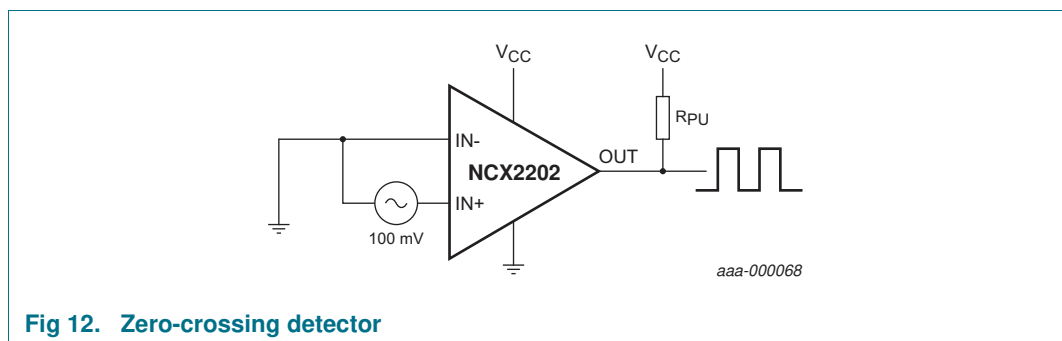
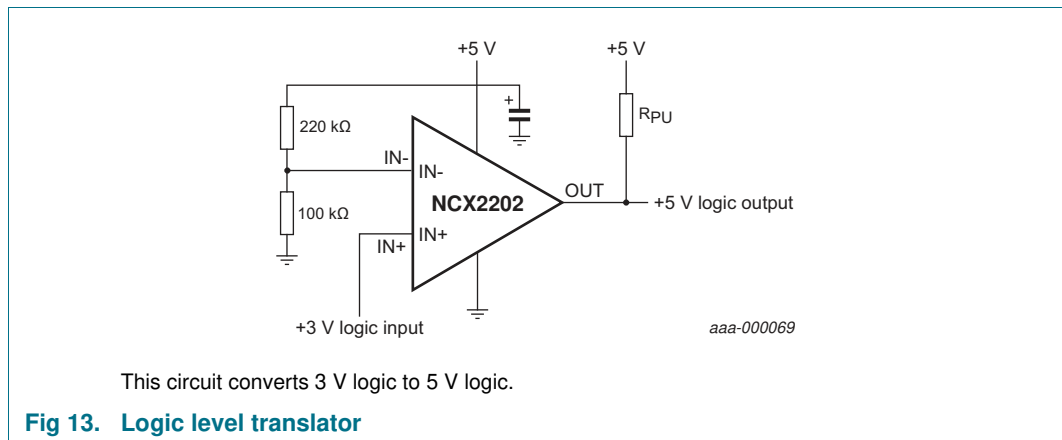

Fig 12. Zero-crossing detector

12.4 Logic level translator

[Figure 13](#) shows the NCX2202 configured as a logic level translator.



13. Package outline

TSSOP5: plastic thin shrink small outline package; 5 leads; body width 1.25 mm

SOT353-1

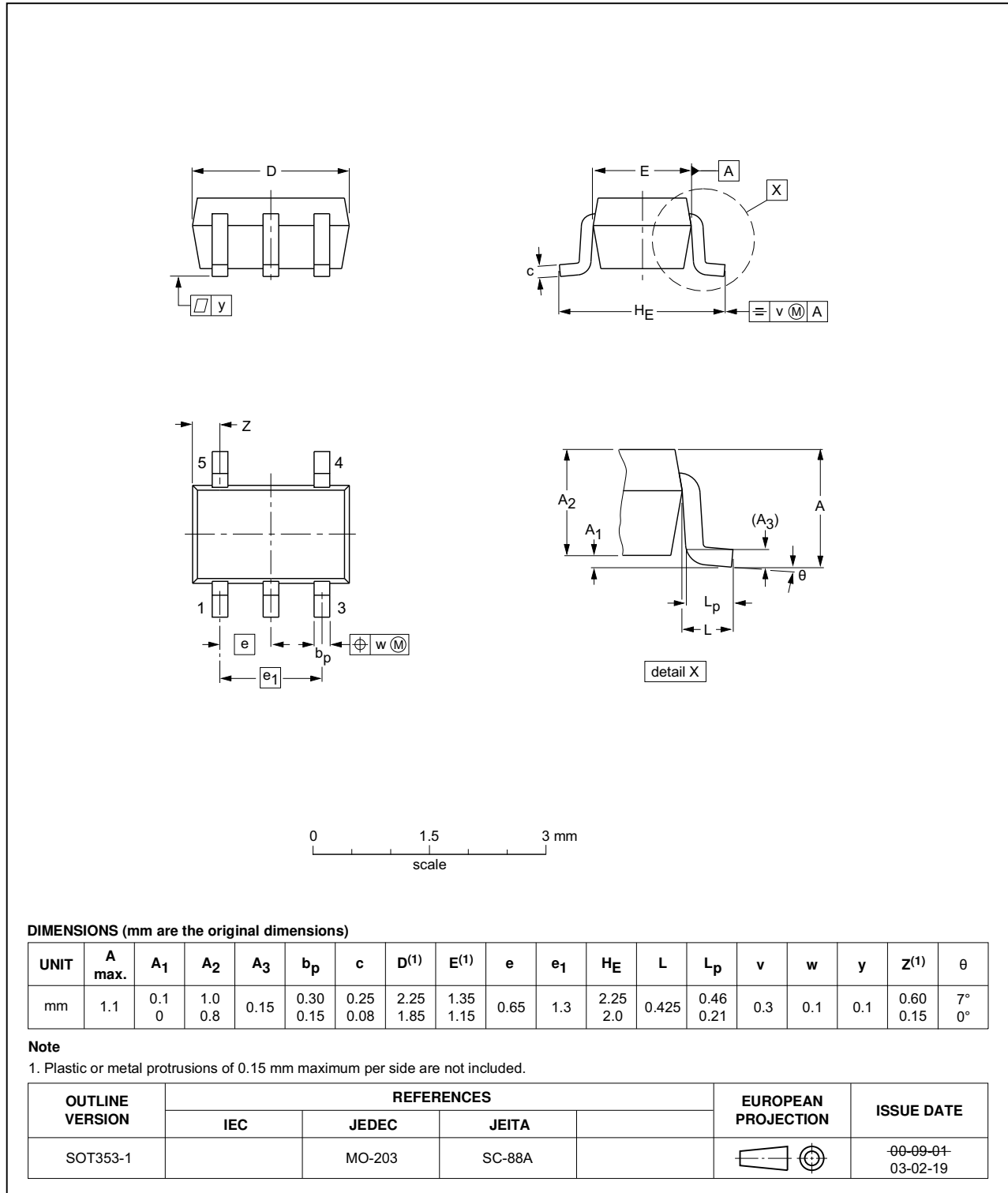

Fig 14. Package outline SOT353-1 (TSSOP5)

XSON6: plastic extremely thin small outline package; no leads; 6 terminals; body 1 x 1.45 x 0.5 mm

SOT886

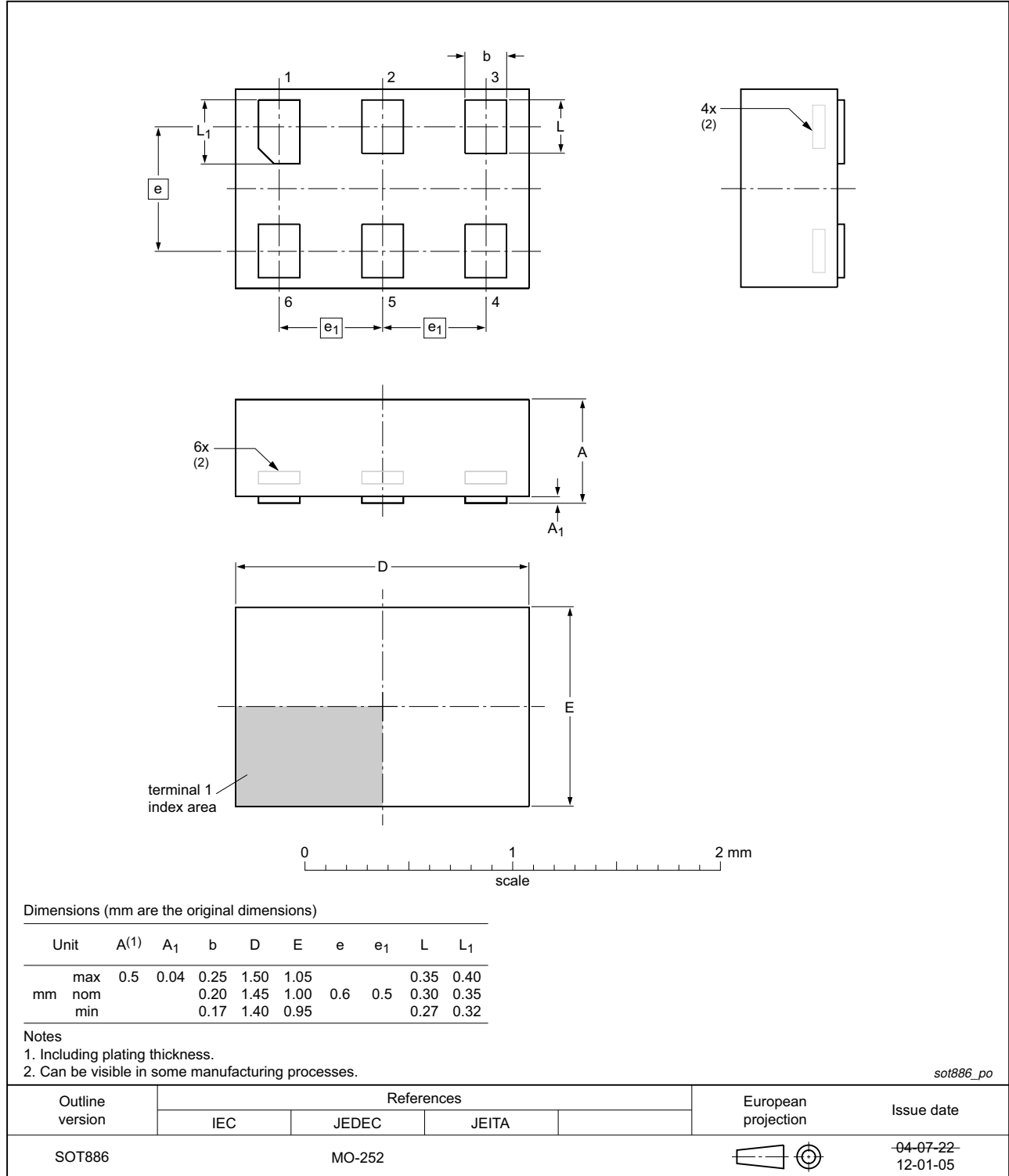

Fig 15. Package outline SOT886 (XSON6)

14. Abbreviations

Table 8. Abbreviations

Acronym	Description
CDM	Charged Device Model
ESD	ElectroStatic Discharge
HBM	Human Body Model

15. Revision history

Table 9. Revision history

Document ID	Release date	Data sheet status	Change notice	Supersedes
NCX2202 v.5.1	20191121	Product data sheet	201909001A	NCX2202 v.5.1
Modifications:	<ul style="list-style-type: none"> Package SOT886 requiring SSB added. Refer to PCN number 201909001A XSON6 (SOT886) Assembly/Test Transfer from ATGD and ATSN to ATBK. 			
NCX2202 v.5	20121030	Product data sheet	-	NCX2202 v.4
Modifications:	<ul style="list-style-type: none"> Class 3A changed into Class 1C (errata) in Section 2. 			
NCX2202 v.4	20120806	Product data sheet	-	NCX2202 v.3
Modifications:	<ul style="list-style-type: none"> Package outline drawing of SOT886 (Figure 15) modified. 			
NCX2202 v.3	20111110	Product data sheet	-	NCX2202 v.2
Modifications:	<ul style="list-style-type: none"> Legal pages updated. 			
NCX2202 v.2	20111020	Product data sheet	-	NCX2202 v.1
NCX2202 v.1	20110720	Product data sheet	-	-

16. Legal information

16.1 Data sheet status

Document status ^{[1][2]}	Product status ^[3]	Definition
Objective [short] data sheet	Development	This document contains data from the objective specification for product development.
Preliminary [short] data sheet	Qualification	This document contains data from the preliminary specification.
Product [short] data sheet	Production	This document contains the product specification.

[1] Please consult the most recently issued document before initiating or completing a design.

[2] The term 'short data sheet' is explained in section "Definitions".

[3] The product status of device(s) described in this document may have changed since this document was published and may differ in case of multiple devices. The latest product status information is available on the Internet at URL <http://www.nxp.com>.

16.2 Definitions

Draft — The document is a draft version only. The content is still under internal review and subject to formal approval, which may result in modifications or additions. NXP Semiconductors does not give any representations or warranties as to the accuracy or completeness of information included herein and shall have no liability for the consequences of use of such information.

Short data sheet — A short data sheet is an extract from a full data sheet with the same product type number(s) and title. A short data sheet is intended for quick reference only and should not be relied upon to contain detailed and full information. For detailed and full information see the relevant full data sheet, which is available on request via the local NXP Semiconductors sales office. In case of any inconsistency or conflict with the short data sheet, the full data sheet shall prevail.

Product specification — The information and data provided in a Product data sheet shall define the specification of the product as agreed between NXP Semiconductors and its customer, unless NXP Semiconductors and customer have explicitly agreed otherwise in writing. In no event however, shall an agreement be valid in which the NXP Semiconductors product is deemed to offer functions and qualities beyond those described in the Product data sheet.

16.3 Disclaimers

Limited warranty and liability — Information in this document is believed to be accurate and reliable. However, NXP Semiconductors does not give any representations or warranties, expressed or implied, as to the accuracy or completeness of such information and shall have no liability for the consequences of use of such information. NXP Semiconductors takes no responsibility for the content in this document if provided by an information source outside of NXP Semiconductors.

In no event shall NXP Semiconductors be liable for any indirect, incidental, punitive, special or consequential damages (including - without limitation - lost profits, lost savings, business interruption, costs related to the removal or replacement of any products or rework charges) whether or not such damages are based on tort (including negligence), warranty, breach of contract or any other legal theory.

Notwithstanding any damages that customer might incur for any reason whatsoever, NXP Semiconductors' aggregate and cumulative liability towards customer for the products described herein shall be limited in accordance with the *Terms and conditions of commercial sale* of NXP Semiconductors.

Right to make changes — NXP Semiconductors reserves the right to make changes to information published in this document, including without limitation specifications and product descriptions, at any time and without notice. This document supersedes and replaces all information supplied prior to the publication hereof.

Suitability for use — NXP Semiconductors products are not designed, authorized or warranted to be suitable for use in life support, life-critical or safety-critical systems or equipment, nor in applications where failure or malfunction of an NXP Semiconductors product can reasonably be expected to result in personal injury, death or severe property or environmental damage. NXP Semiconductors and its suppliers accept no liability for inclusion and/or use of NXP Semiconductors products in such equipment or applications and therefore such inclusion and/or use is at the customer's own risk.

Applications — Applications that are described herein for any of these products are for illustrative purposes only. NXP Semiconductors makes no representation or warranty that such applications will be suitable for the specified use without further testing or modification.

Customers are responsible for the design and operation of their applications and products using NXP Semiconductors products, and NXP Semiconductors accepts no liability for any assistance with applications or customer product design. It is customer's sole responsibility to determine whether the NXP Semiconductors product is suitable and fit for the customer's applications and products planned, as well as for the planned application and use of customer's third party customer(s). Customers should provide appropriate design and operating safeguards to minimize the risks associated with their applications and products.

NXP Semiconductors does not accept any liability related to any default, damage, costs or problem which is based on any weakness or default in the customer's applications or products, or the application or use by customer's third party customer(s). Customer is responsible for doing all necessary testing for the customer's applications and products using NXP Semiconductors products in order to avoid a default of the applications and the products or of the application or use by customer's third party customer(s). NXP does not accept any liability in this respect.

Limiting values — Stress above one or more limiting values (as defined in the Absolute Maximum Ratings System of IEC 60134) will cause permanent damage to the device. Limiting values are stress ratings only and (proper) operation of the device at these or any other conditions above those given in the Recommended operating conditions section (if present) or the Characteristics sections of this document is not warranted. Constant or repeated exposure to limiting values will permanently and irreversibly affect the quality and reliability of the device.

Terms and conditions of commercial sale — NXP Semiconductors products are sold subject to the general terms and conditions of commercial sale, as published at <http://www.nxp.com/profile/terms>, unless otherwise agreed in a valid written individual agreement. In case an individual agreement is concluded only the terms and conditions of the respective agreement shall apply. NXP Semiconductors hereby expressly objects to applying the customer's general terms and conditions with regard to the purchase of NXP Semiconductors products by customer.

No offer to sell or license — Nothing in this document may be interpreted or construed as an offer to sell products that is open for acceptance or the grant, conveyance or implication of any license under any copyrights, patents or other industrial or intellectual property rights.

Export control — This document as well as the item(s) described herein may be subject to export control regulations. Export might require a prior authorization from competent authorities.

Non-automotive qualified products — Unless this data sheet expressly states that this specific NXP Semiconductors product is automotive qualified, the product is not suitable for automotive use. It is neither qualified nor tested in accordance with automotive testing or application requirements. NXP Semiconductors accepts no liability for inclusion and/or use of non-automotive qualified products in automotive equipment or applications.

In the event that customer uses the product for design-in and use in automotive applications to automotive specifications and standards, customer (a) shall use the product without NXP Semiconductors' warranty of the product for such automotive applications, use and specifications, and (b) whenever customer uses the product for automotive applications beyond

NXP Semiconductors' specifications such use shall be solely at customer's own risk, and (c) customer fully indemnifies NXP Semiconductors for any liability, damages or failed product claims resulting from customer design and use of the product for automotive applications beyond NXP Semiconductors' standard warranty and NXP Semiconductors' product specifications.

Translations — A non-English (translated) version of a document is for reference only. The English version shall prevail in case of any discrepancy between the translated and English versions.

16.4 Trademarks

Notice: All referenced brands, product names, service names and trademarks are the property of their respective owners.

17. Contact information

For more information, please visit: <http://www.nxp.com>

For sales office addresses, please send an email to: salesaddresses@nxp.com

18. Contents

1	General description	1
2	Features and benefits	1
3	Applications	1
4	Ordering information	1
4.1	Ordering options	2
5	Functional diagram	2
6	Pinning information	2
6.1	Pinning	2
6.2	Pin description	2
7	Limiting values	3
8	Recommended operating conditions	3
9	Static characteristics	3
10	Dynamic characteristics	5
11	Graphs	5
12	Application information	8
12.1	Operating description	8
12.2	Output stage	8
12.3	Zero-crossing detector	8
12.4	Logic level translator	8
13	Package outline	10
14	Abbreviations	12
15	Revision history	12
16	Legal information	13
16.1	Data sheet status	13
16.2	Definitions	13
16.3	Disclaimers	13
16.4	Trademarks	14
17	Contact information	14
18	Contents	15

Please be aware that important notices concerning this document and the product(s) described herein, have been included in section 'Legal information'.

© NXP B.V. 2019.

All rights reserved.

For more information, please visit: <http://www.nxp.com>

For sales office addresses, please send an email to: salesaddresses@nxp.com

Date of release: 21 November 2019

Document identifier: NCX2202