

P	LTR	DESCRIPTION	DATE	DWN	APVD
	B5	REVISE PER ECO-20-012556	08SEP2020	TL	HL

NOTE:

- MATERIAL:
HOUSING: LCP WITH 30% GF, UL 94V-0, COLOR:WHITE OR BLACK (SEE PAGE 2).
CONTACTS: PHOSPHOR BRONZE.
- FINISH:
CONTACTS: GOLD PLATED (SEE TABLE) ON CONTACT AREA
2.54μm [100μ"] MIN. MATTE-TIN PLATING ON SOLDER AREA
1.27μm [50μ"] MIN. NICKEL UNDERPLATED OVERALL.
- WAVE SOLDER CAPABLE TO 265°C PER TEST SPEC 109-202, CONDITION B.
- REFLOW SOLDER CAPABLE TO 260°C PER TE SPEC. TEC-109-201, CONDITION B.

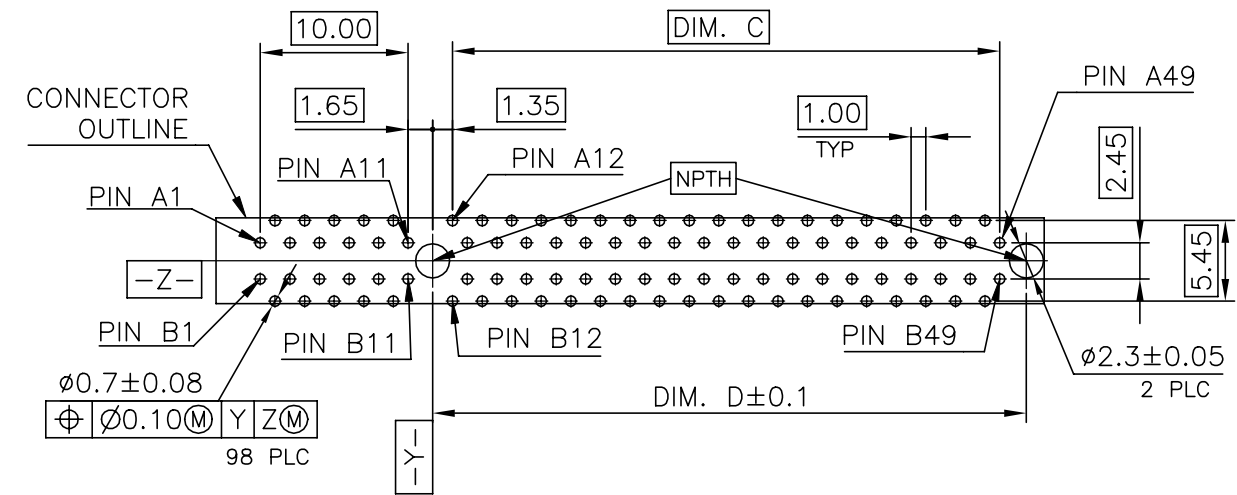
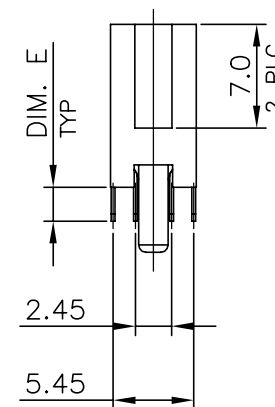
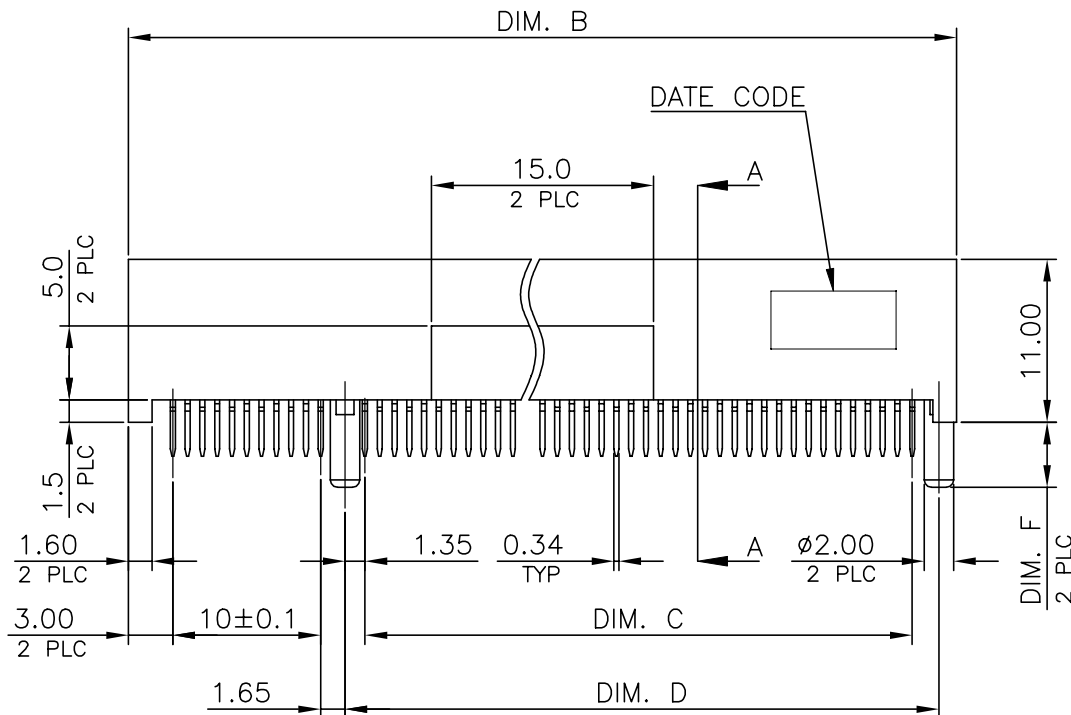
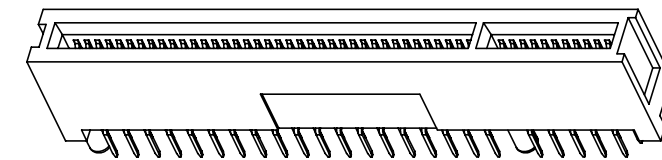
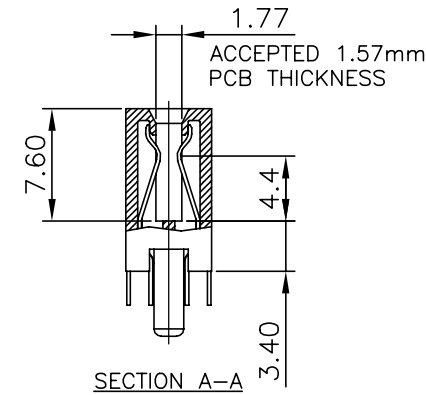
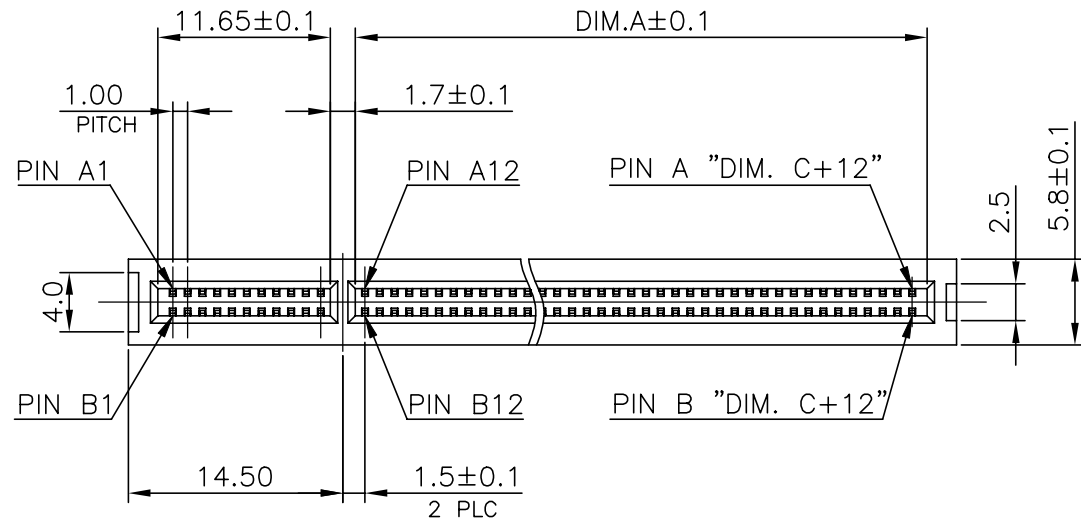

TOLERANCE: ±0.05
RECOMMENDED PCB LAYOUT

THIS DRAWING IS A CONTROLLED DOCUMENT.		DWN	E. LIU	11NOV2009	TE Connectivity Ltd.	
		CHK	W. KODAMA	11NOV2009		
		APVD	S. CHIEN	11NOV2009		
		PRODUCT SPEC	108-57787			
DIMENSIONS:		TOLERANCES UNLESS OTHERWISE SPECIFIED:			NAME	
mm		0 PLC ± - 1 PLC ± 0.3 2 PLC ± 0.2 3 PLC ± 0.15 4 PLC ± - ANGLES ± 3			PCI EXPRESS CARD EDGE CONNECTOR VERTICAL ,SLIM, DIP TYPE	
MATERIAL		FINISH			SIZE	RESTRICTED TO
-		-			A3	-
		WEIGHT			CAGE CODE	DRAWING NO
		SEE TABLE			00779	C=2041612
		CUSTOMER DRAWING			SCALE	SHEET
					1:1	1 of 5
					REV	B5

REVISIONS

P	LTR	DESCRIPTION	DATE	DWN	APVD
-	-	SEE SHEET 1	-	-	-

NOTE(CONTINUED):

- ⚠ SPECIAL PACKAGE PER CUSTOMER REQUEST(SEE PAGE 5).
- ⚠ STANDARD PACKAGE PER CUSTOMER REQUEST(SEE PAGE 4).

PACKAGE	WEIGHT (GRAMS)	DIM F	DIM E	DIM D	DIM C	DIM B	DIM A	POS	MIN. GOLD THICKNESS	PART NUMBER
⚠	6.8	4.40	2.3	73.15	70.00	89.00	71.65	164	0.381μm [15μ"]	1-2041612-5
⚠	6.8	2.00	1.5	73.15	70.00	89.00	71.65	164	0.762μm [30μ"]	2041612-9
									GOLD FLASH	2041612-8
									0.381μm [15μ"]	2041612-7
⚠	6.8	4.40	2.3	73.15	70.00	89.00	71.65	164	0.762μm [30μ"]	2041612-6
									0.381μm [15μ"]	2041612-5
									GOLD FLASH	2041612-4
⚠	4.2	4.40	2.3	40.15	37.00	56.00	38.65	98	0.762μm [30μ"]	2041612-3
									0.381μm [15μ"]	2041612-2
									GOLD FLASH	2041612-1

HOUSING COLOR : WHITE

PACKAGE	WEIGHT (GRAMS)	DIM F	DIM E	DIM D	DIM C	DIM B	DIM A	POS	MIN. GOLD THICKNESS	PART NUMBER
⚠	4.2	4.40	1.8	40.15	37.00	56.00	38.65	98	0.762μm [30μ"]	6-2041612-3
⚠	6.8	4.40	2.3	73.15	70.00	89.00	71.65	164	0.381μm [15μ"]	4-2041612-5
⚠	6.8	2.00	1.5	73.15	70.00	89.00	71.65	164	0.762μm [30μ"]	3-2041612-9
									GOLD FLASH	3-2041612-8
									0.381μm [15μ"]	3-2041612-7
⚠	6.8	4.40	2.3	73.15	70.00	89.00	71.65	164	0.762μm [30μ"]	3-2041612-6
									0.381μm [15μ"]	3-2041612-5
									GOLD FLASH	3-2041612-4
⚠	4.2	4.40	2.3	40.15	37.00	56.00	38.65	98	0.762μm [30μ"]	3-2041612-3
									0.381μm [15μ"]	3-2041612-2
									GOLD FLASH	3-2041612-1

HOUSING COLOR : BLACK

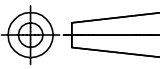
THIS DRAWING IS A CONTROLLED DOCUMENT.		DWN E. LIU 11NOV2009	 TE Connectivity Ltd.			
DIMENSIONS: mm		CHK W. KODAMA 11NOV2009				
		APVD S. CHIEN 11NOV2009				
TOLERANCES UNLESS OTHERWISE SPECIFIED:		NAME PCI EXPRESS CARD EDGE CONNECTOR VERTICAL ,SLIM, DIP TYPE				
MATERIAL		PRODUCT SPEC 108-57787	SIZE	CAGE CODE	DRAWING NO	RESTRICTED TO
FINISH		APPLICATION SPEC	A3	00779	C=2041612	-
-		WEIGHT SEE TABLE	SCALE 1:1		SHEET 2 of 5	REV B5
-		CUSTOMER DRAWING				

P	LTR	DESCRIPTION	DATE	DWN	APVD
-	-	SEE SHEET 1	-	-	-

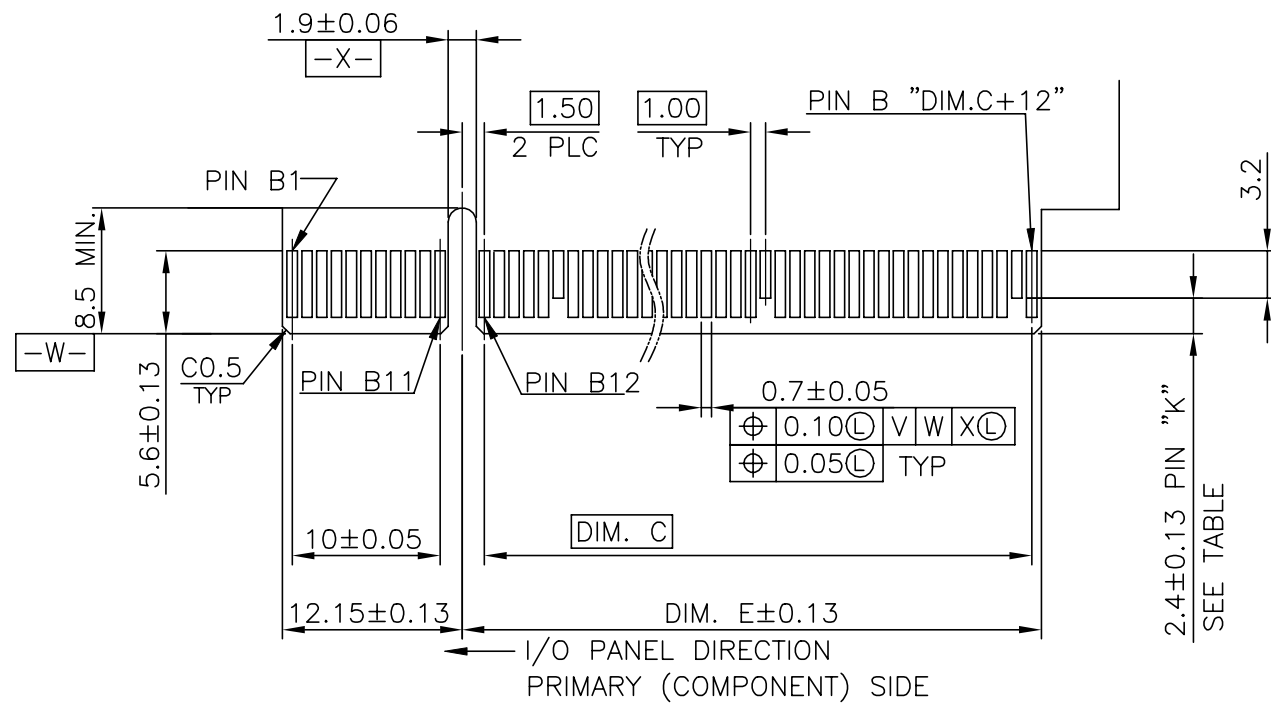

ADD-IN CARD EDGE-FINGER DIMENSIONS

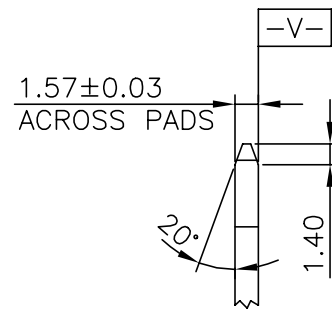
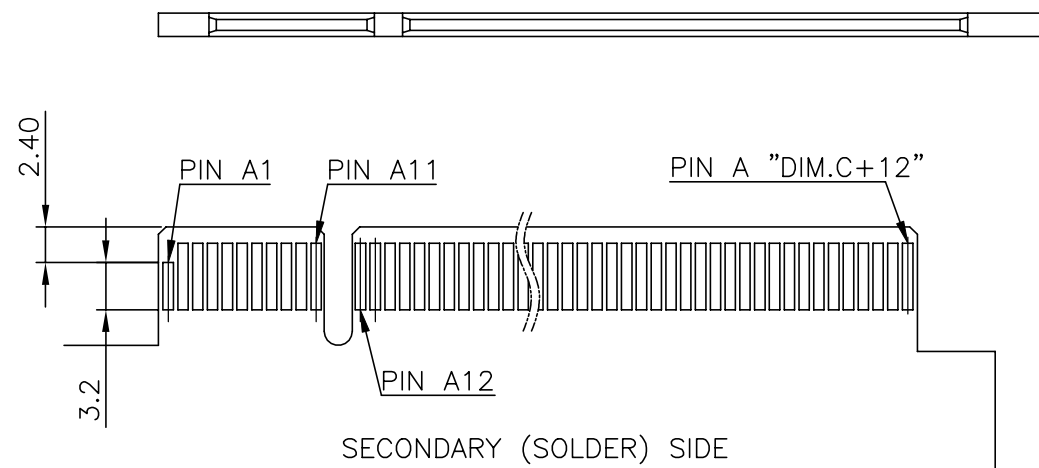

164	70.0	72.15	B17,B31,B48,B81
98	37.0	39.15	B17,B31,B48
POS.	DIM. C	DIM. E	"K"

THIS DRAWING IS A CONTROLLED DOCUMENT.		DWN E. LIU 11NOV2009	 TE Connectivity Ltd.	
DIMENSIONS: mm		CHK W. KODAMA 11NOV2009		
TOLERANCES UNLESS OTHERWISE SPECIFIED:		APVD S. CHIEN 11NOV2009	NAME PCI EXPRESS CARD EDGE CONNECTOR VERTICAL ,SLIM, DIP TYPE	
0 PLC ± - 1 PLC ± 0.3 2 PLC ± 0.2 3 PLC ± 0.15 4 PLC ± - ANGLES ± 3		PRODUCT SPEC 108-57787	RESTRICTED TO	
MATERIAL		APPLICATION SPEC	SIZE A3	CAGE CODE 00779
FINISH		WEIGHT SEE TABLE	DRAWING NO C=2041612	REV B5
CUSTOMER DRAWING			SCALE 1:1	SHEET 3 of 5

REVISIONS

P	LTR	DESCRIPTION	DATE	DWN	APVD
-	-	SEE SHEET 1	-	-	-

NOTES:

1. MATERIAL
 - 1.1 TRAY: PVC
 - 1.2 CONVER TRAY: PVC
 - 1.3 SHIPPING BOX: CORRUGATED FIBER
2. DIMENSION
 - 2.1 TRAY: 320mm(L) X 295mm(W) X 21mm(H)
 - 2.2 BOX: 326mm(L) X 300mm(W) X 305mm(H)
3. QUANTITY: SEE TABLE.
4. WEIGHT: SEE TABLE.

164	60	14	840	5.7	9.4
98	100	14	1400	5.9	9.6
POS NO.	PIECES PER TRAY	TRAYS PER BOX	PIECES PER BOX	NET WEIGHT (Kg)	GROSS WEIGHT (Kg)

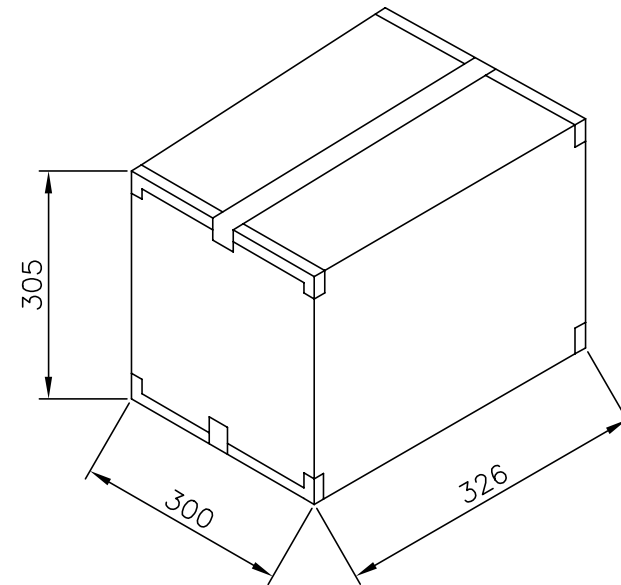
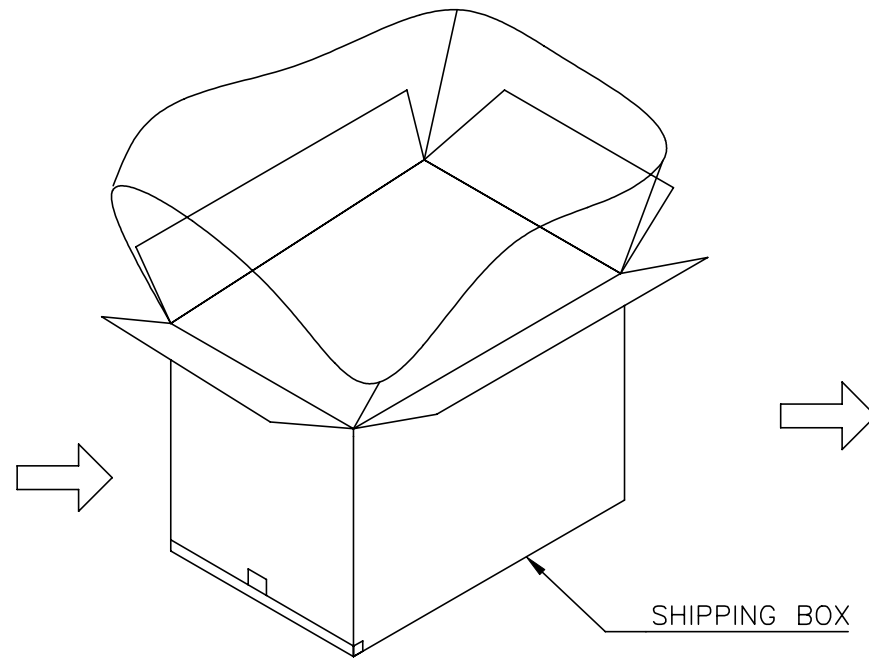
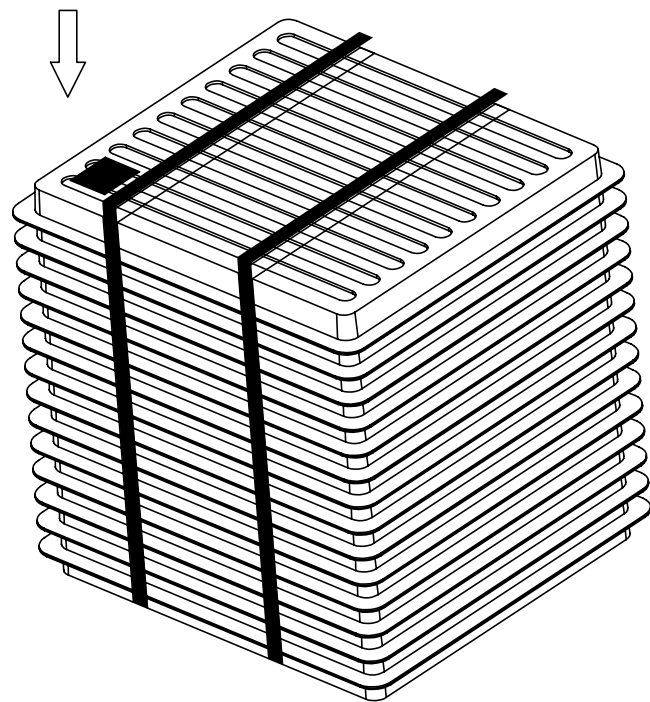
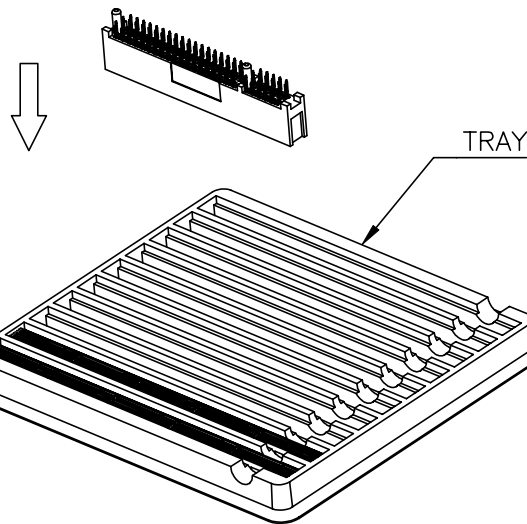
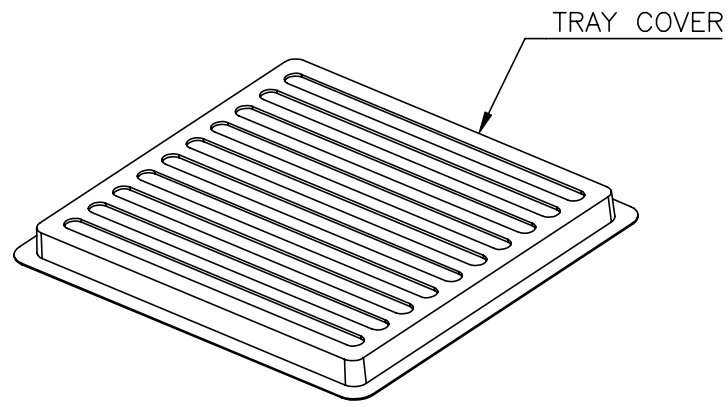

THIS DRAWING IS A CONTROLLED DOCUMENT.		DWN E. LIU 11NOV2009	TE Connectivity Ltd.		
		CHK W. KODAMA 11NOV2009			
DIMENSIONS: mm		APVD S. CHIEN 11NOV2009	NAME PCI EXPRESS CARD EDGE CONNECTOR VERTICAL ,SLIM, DIP TYPE		
		PRODUCT SPEC 108-57787	RESTRICTED TO		
TOLERANCES UNLESS OTHERWISE SPECIFIED:		APPLICATION SPEC	SIZE A3	CAGE CODE 00779	DRAWING NO C=2041612
0 PLC ± - 1 PLC ± - 2 PLC ± - 3 PLC ± - 4 PLC ± - ANGLES ± -		WEIGHT SEE TABLE	REV B5		
MATERIAL -		FINISH -	SCALE 1:1 SHEET 4 of 5		
CUSTOMER DRAWING					

REVISIONS

P	LTR	DESCRIPTION	DATE	DWN	APVD
-	-	SEE SHEET 1	-	-	-

NOTES:

- MATERIAL
 - TRAY; ABS, COLOR: BLACK.
 - CARTON: CORRUGATED FIBER.
 - TRANSPARENT BAG: PE, SIZE: 500mm*380mm*0.06mm.
- EACH BAG SHALL BE INCLUDED:: * DESICCANT
- DIMENSION
 - TRAY: 330mm(L) X 276mm(W) X 21mm(H)
 - BOX: 345mm(L) X 295mm(W) X 335mm(H)
- QUANTITY: SEE TABLE.
- WEIGHT: SEE TABLE.

POS NO.	PIECES PER TRAY	TRAYS PER BOX	PIECES PER BOX	NET WEIGHT (Kg)	GROSS WEIGHT (Kg)
164	66	14	924	5.7	11

D

C

B

A

D

C

B

A

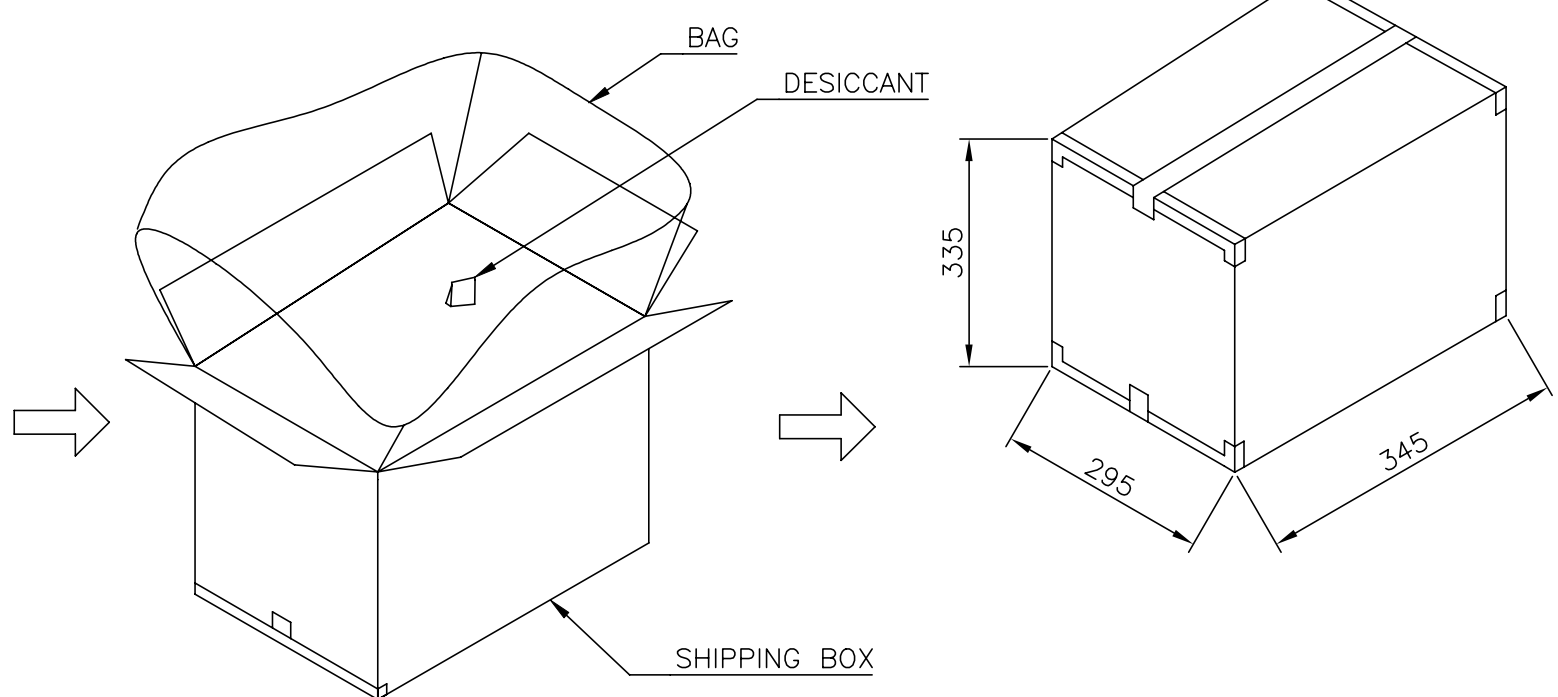
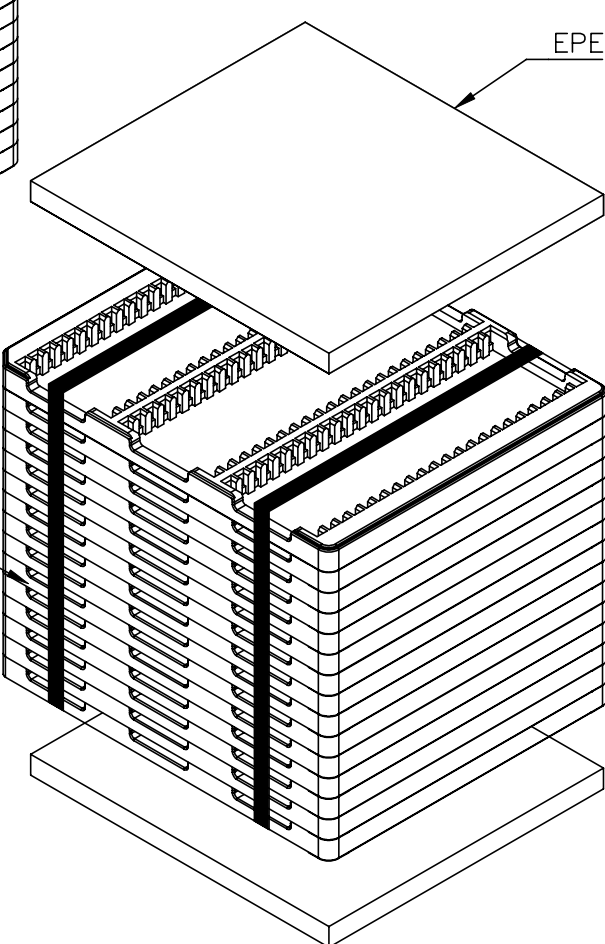
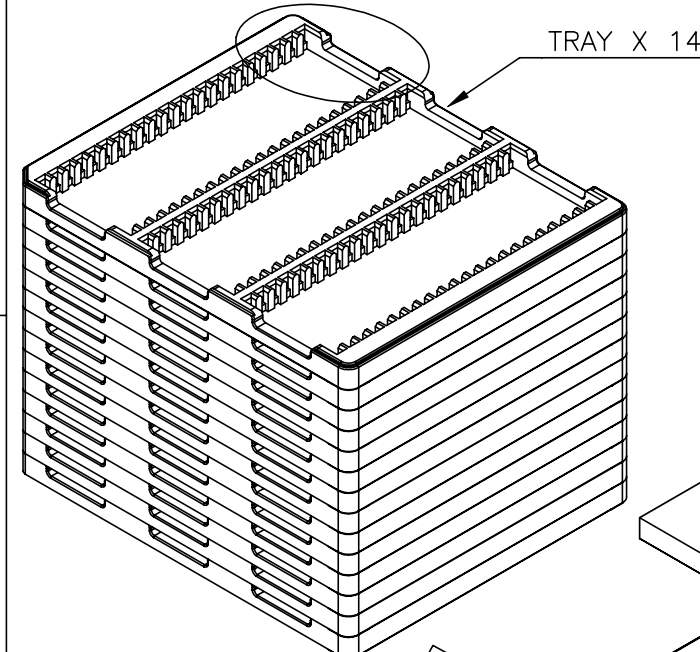
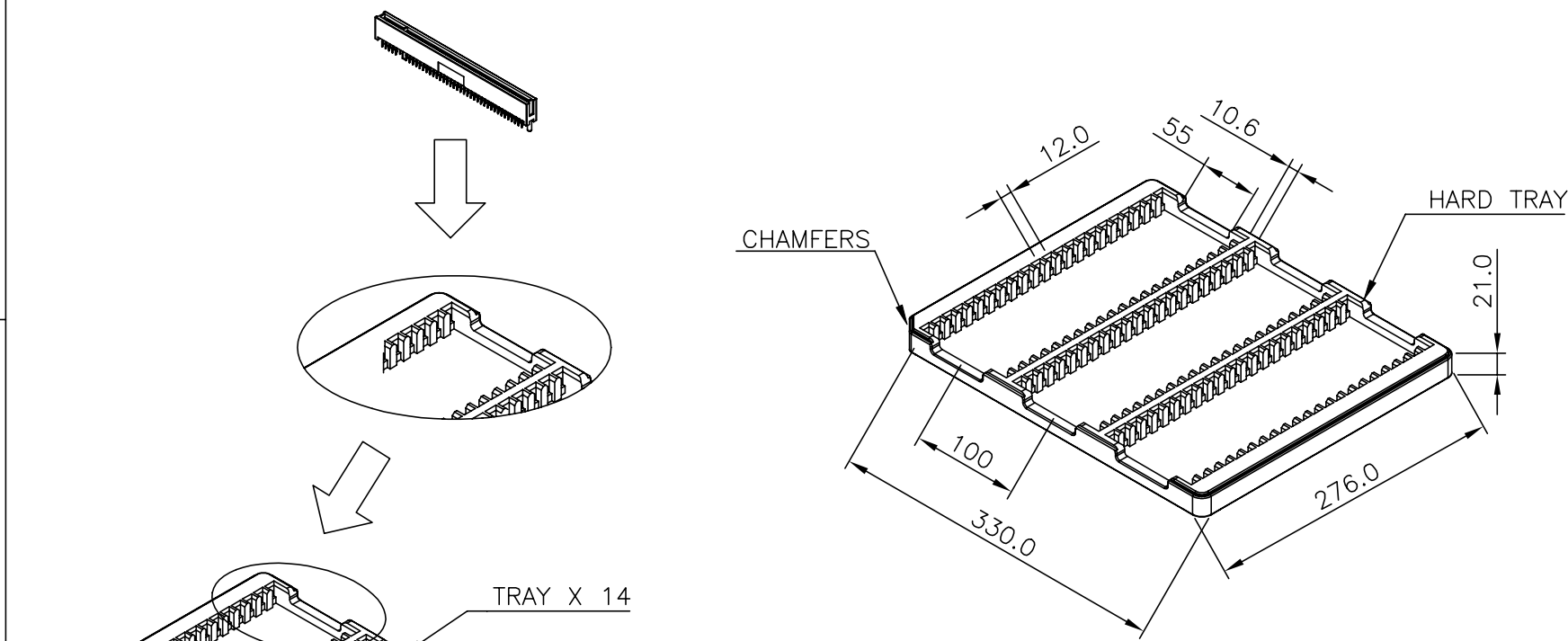

THIS DRAWING IS A CONTROLLED DOCUMENT.

DIMENSIONS: mm	TOLERANCES UNLESS OTHERWISE SPECIFIED: 0 PLC ± - 1 PLC ± - 2 PLC ± - 3 PLC ± - 4 PLC ± - ANGLES ± -	DWN E. LIU 11NOV2009	TE Connectivity Ltd. PCI EXPRESS CARD EDGE CONNECTOR VERTICAL ,SLIM, DIP TYPE
	MATERIAL	CHK W. KODAMA 11NOV2009	
	FINISH	APVD S. CHIEN 11NOV2009	
		PRODUCT SPEC 108-57787	
		APPLICATION SPEC	NAME
		WEIGHT SEE TABLE	SIZE A3
		CUSTOMER DRAWING	CAGE CODE 00779
			DRAWING NO C=2041612
			RESTRICTED TO
			SCALE 1:1
			SHEET 5 of 5
			REV B5