

| REVISION RECORD | | | | |
|-----------------|-----|-------------|-------------------|------|
| REV | ECO | DESCRIPTION | DRFT | CHKD |
| △ | | ADD TYPE | PETERS 1/15/05 | |

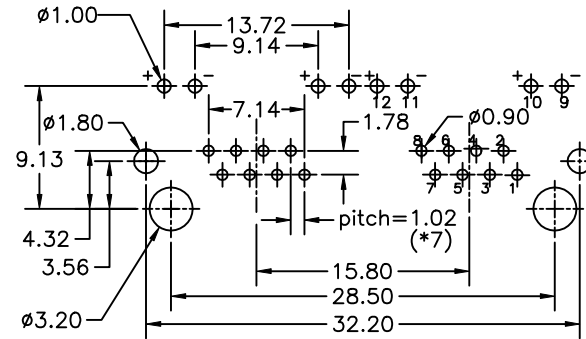
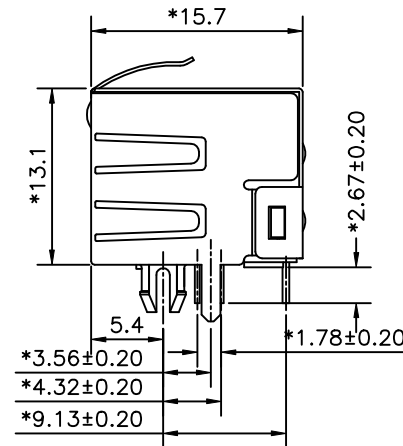
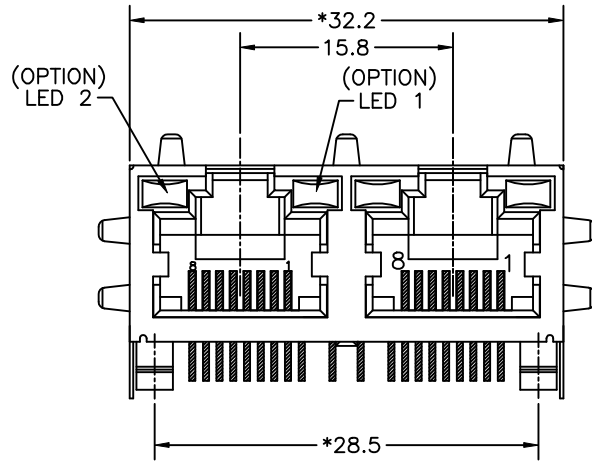

PC Board Layout(t=1.60)
Component Side Shown

NOTES:

ELECTRICAL:

- VOLTAGE RATING : 125 VAC RMS.
- CURRENT RATING : 1.5 AMP.
- CONTACT RESISTANCE : 30 MILLIOHMS MAX.
- INSULATION RESISTANCE: 1000 MEGOHMS MIN @ 500 VDC.
- DIELECTRIC STRENGTH : 1000 VAC RMS 60Hz, 1MIN.
- LED RATINGS: FORWARD VOLTAGE: 2.2 VOLTS TYPICAL.
REVERSE VOLTAGE: 5 VOLTS MAXIMUM.
- OPERATING: 750 CYCLES MIN.

MECHANICAL:

- HOUSING MATERIAL : FR52. UL94V-0. COLOR-BLACK.
- INSERT MATERIAL : FR52. UL94V-0. COLOR-BLACK.
- BACK PLATE MATERIAL : FR52. COLOR-BLACK.
- LED SIZE : 3.2*2.0*7.0*P=2.54mm.
- SHIELD MATERIAL : COPPER ALLOY 0.25mm THICKNESS PLATING NI.
- CONTACT MATERIAL : PHOSPHOR BRONZE 0.35mm THICKNESS OR Ø0.46.
- PLATING : GOLD PLATING OVER NICKEL.
- PCB RETENTION PRE-SOLDER : 1 LB MIN.
- PCB RETENTION POST-SOLDER: 10 LBS MIN.

ENVIRONMENTAL:

- STORAGE : -40°C TO +85°C.
 - OPERATION: 0°C TO 70°C.
- MATES WITH MODULAR PLUG CONFORMING TO
FCC PART 68, SUBPART F.
CUL FILE No:E163191

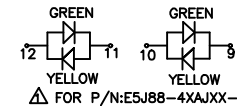

PART NUMBER: E 5J 8 8 - X X A J X X-L

- 1-LED1:GREEN ,LED2:YELLOW .
- 2-LED1:GREEN ,LED2:GREEN .
- 3-LED1:YELLOW ,LED2:GREEN .
- △4-LED1:G+Y ,LED2:G+Y .
- 5-LED1:RED ,LED2:GREEN .
- 7-LED1:YELLOW ,LED2:YELLOW .

- 1-NO TAB
- 2-TOP TABS.
- 3-SIDE TABS.
- 4-TOP TABS & SIDE TABS.

PLATING: 1-3u" 2-6u"
3-15u" 4-30u" 5-50u"

- 1-plate Tin shield stamp pin,No3 era led
- 2-plate Ni shield stamp pin,No3 era led
- 3-plate Tin shield round pin,No3 era led
- 4-plate Ni shield round pin,No3 era led

J-W/O LOGO FR52.

| | | | | | |
|----------------------------|--|----------------------|----------------|--|--|
| MM (INCH) | | DFTO Jake | DATE 05/05/04 | FULL RISE ELECTRONIC CO., LTD | |
| TOLERANCES EXCEPT AS NOTED | | CHKD JAKE | DATE 2005/1/15 | | |
| | | MFO | DATE | TITLE RJ45 SIDE ENTRY LED GANG JACK | |
| | | APPV LUSHENG | DATE 2005/1/15 | | |
| DETAILED LISTS | | MATERIAL : | | DRAWING NO. GE5J3135 | |
| ANGLES ± | | QT'Y : | | /PART NO. SEE NOTE | |
| THIRD ANGLE PROJECTION | | FINISH : | | SIZE A3 | |
| | | SCALE : 50:19 | | REV 1 | |
| | | DO NOT SCALE DRAWING | | 01/15/05 | |
| | | SHEET X | | OF Y | |