

REVISIONS					
P	LTR	DESCRIPTION	DATE	DWN	APVD
D		REVISED PER ECO-16-018632	06APR2017	SK	PO

SPECIFICATIONS:

MATERIAL:

HOUSING, THERMOPLASTIC, UL94-V0, BLACK
 ACTUATOR, THERMOPLASTIC, UL94-V0, COLOR SEE TABLE
 TERMINAL, COPPER ALLOY, PLATE- SILVER OVER NICKEL
 COVER, STAINLESS STEEL
 CONTACT, STAINLESS STEEL, SILVER PLATE

ELECTRICAL:

MAX CONTACT RATING: 50MILLIAMPS@24V DC
 MIN CONTACT RATING: 10MICROAMPS@1V DC
 INITIAL CONTACT RESISTANCE, 100 MILLIOHMS MAX, PER EIA-364-23B, EACH POSITION
 INSULATION RESISTANCE, 100 MEGOHM MIN. PER EIA-364-21C EACH POSITION
 DIELECTRIC STRENGTH, 500 V AC FOR 1 MINUTE, PER EIA-364-20B, CONDITION 1, EACH POSITION.
 CONTACT BOUNCE, 10 MILLISECOND MAX, PER EIA 448-1B, METHOD 15

MECHANICAL:

ACTUATION FORCE, SEE TABLE
 ACTUATION TRAVEL, .2 +/- .1 mm
 LIFE EXPECTANCY, SEE TABLE, VALUES GIVEN ARE MINIMUM, (2 CYCLES PER SECOND AND 150% ACTUATION FORCE), PER EIA-448 METHODS 8 & 9
 VIBRATION, PER EIA 364-28D, CONDITION VII, LEVEL E, DURATION 1.5 HOURS
 MECHANICAL SHOCK, PER EIA-364-27C, CONDITION A

ENVIRONMENTAL

OPERATING TEMPERATURE, -35 TO +85 DEGREES C
 STORAGE TEMPERATURE, -35 TO +85 DEGREES C
 HUMIDITY AND TEMPERATURE CYCLING PER EIA-364-31B, METHOD III
 THERMAL SHOCK, PER EIA-364-32C, -35 TO +85 DEGREES C
 SOLDERABILITY, PER EIA-364-52, CLASS 2, CATEGORY 1, TEMP, 245 DEGREES C MAX, TIME, 2.5 SECONDS MAX, 95% MINIMUM COVERAGE
 RESISTANCE TO SOLDER HEAT, PER 109-201 COND B
 TAPE AND REEL PACKAGING PER EIA 481, TAPE WIDTH 12mm, PITCH 8.0mm, 3000 PER REEL

1. ALL MATERIALS AND FINISHES SHALL COMPLY WITH EU DIRECTIVE 2002/95/EC OF 27JAN2003 (ROHS)

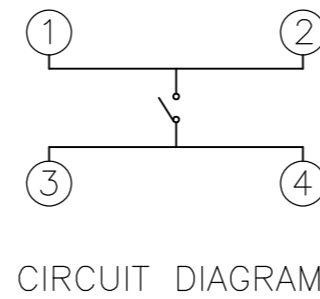
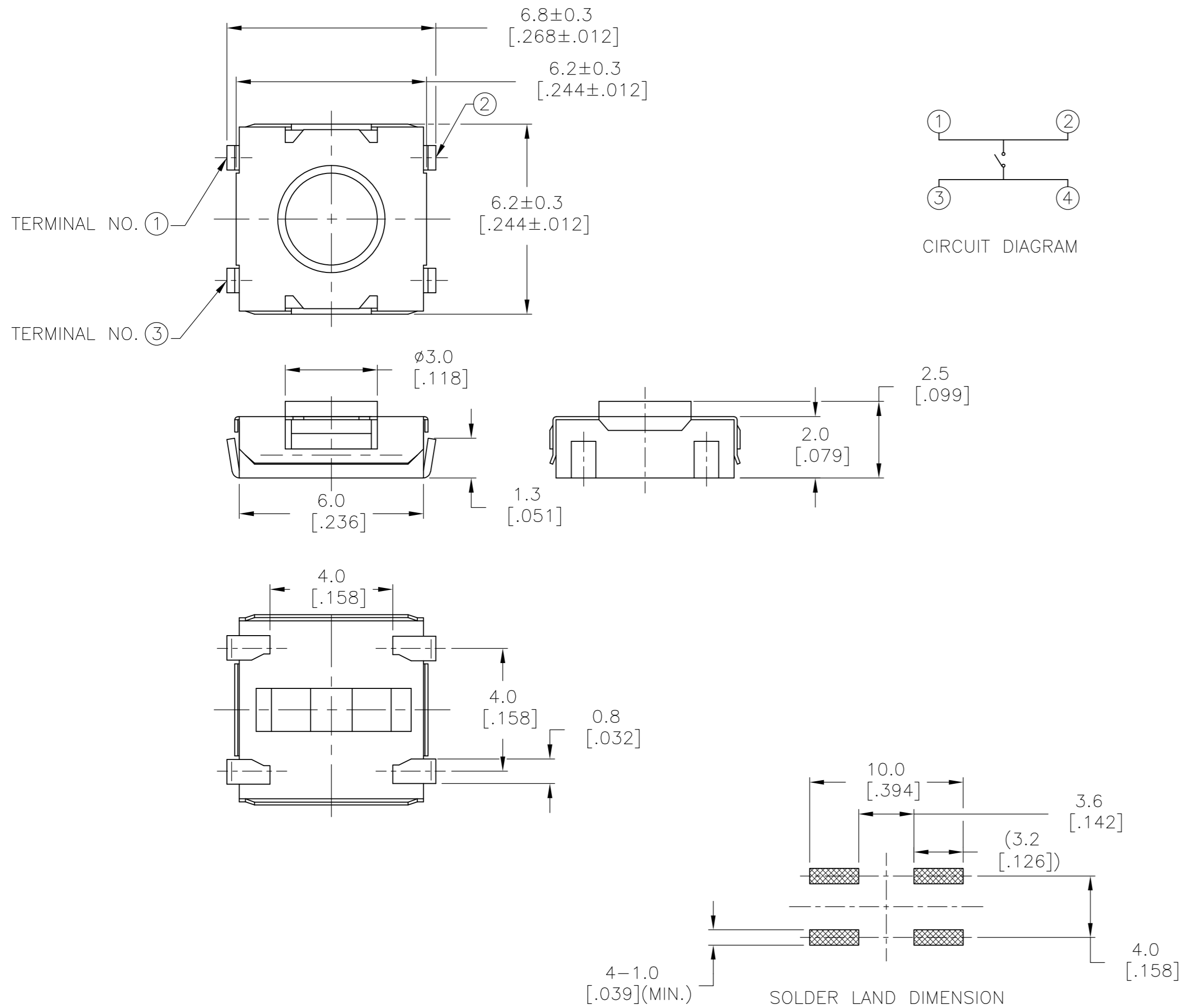

PACKAGING	CYCLE LIFE	ACT. COLOR	FORCE	DIM L	PART NO.
T&R	1,00,000	VIOLET	260±50gf	2.5mm	1571625-8
BULK	1,00,000	VIOLET	260±50gf	2.5mm	1571625-7
T&R	1,000,000	RED	160±50gf	2.5mm	1571625-6
BULK	1,000,000	RED	160±50gf	2.5mm	1571625-5
T&R	1,000,000	GREEN	100±50gf	2.5mm	1571625-4
BULK	1,000,000	GREEN	100±50gf	2.5mm	1571625-3
T&R	2,000,000	IVORY	50±30gf	2.5mm	1571625-2
BULK	2,000,000	IVORY	50±30gf	2.5mm	1571625-1

THIS DRAWING IS A CONTROLLED DOCUMENT.		DWN	M.BINNER	22SEP03	
DIMENSIONS: mm [INCHES]		CHK	M.SARVER	22SEP03	
TOLERANCES UNLESS OTHERWISE SPECIFIED:		APVD	M.SARVER	22SEP03	
0 PLC ± - 1 PLC ± 0.2 2 PLC ± - 3 PLC ± - 4 PLC ± - ANGLES ± -		PRODUCT SPEC	NAME		
MATERIAL SEE NOTES		FINISH	-		NAME
		WEIGHT	0	PUSHBUTTON SWITCH, 6X6 mm, SMT, J-LEAD	
		CUSTOMER DRAWING	A2		RESTRICTED TO
		SCALE	8:1	SHEET	1 OF 1
		DRAWING NO	C=1571625		REV
		REV	D		