

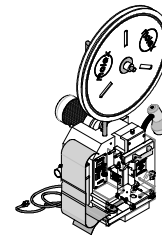

**TM-3000 / TM4000
Safety Guard
Upgrade Kit**

Application Tooling Specification Sheet



Order No. 64016-2595

FEATURES

- Required to operate the 64016-2000 Taped Terminal Crimp Module in TM-3000 presses.
- Includes Standard "Point of Operation" safety guard insert for use with Mini-Mac, Fine Adjust, Rear Feed, and Tape applicators.
- Adapts to a variety of optional, easy to install "point of operation" guards.
- "Point of Operation" Guard adjusts with 4 screws for optimum wire to terminal alignment.
- Increased visibility to crimp area.
-

SCOPE

Applicable presses: Molex 63801-7200, 63801-7300, 63801-7600.

New Guard

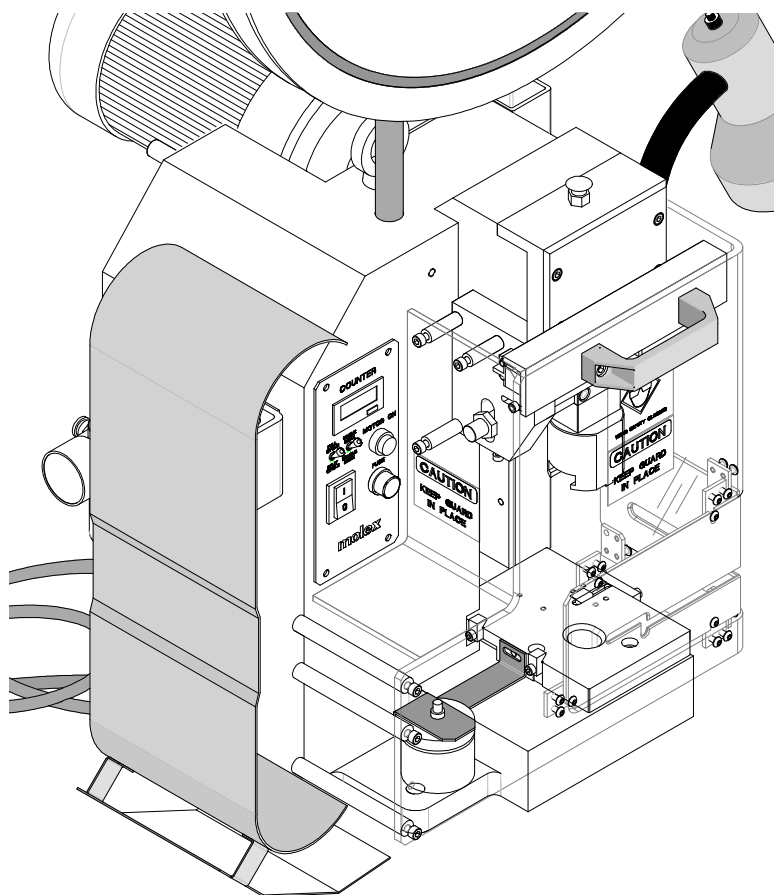

Old Styles of the TM3000 Guards

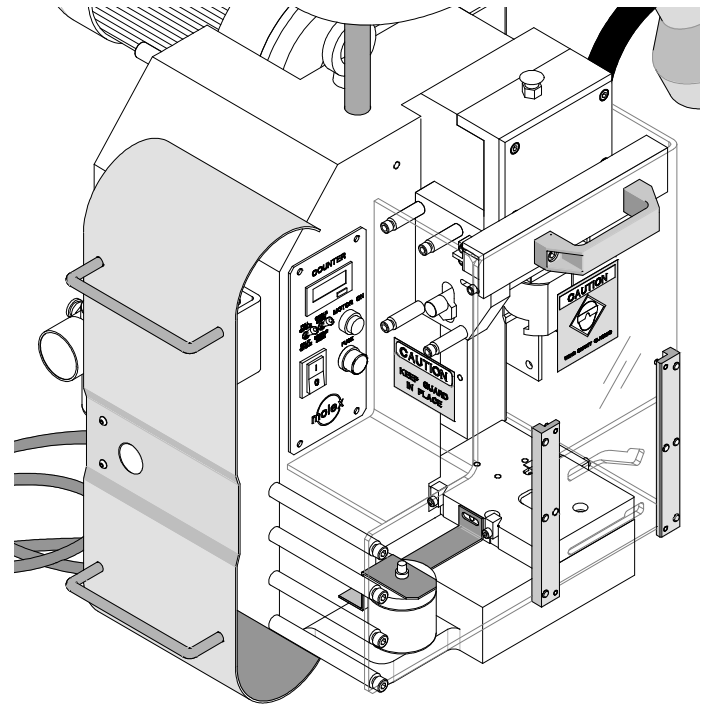
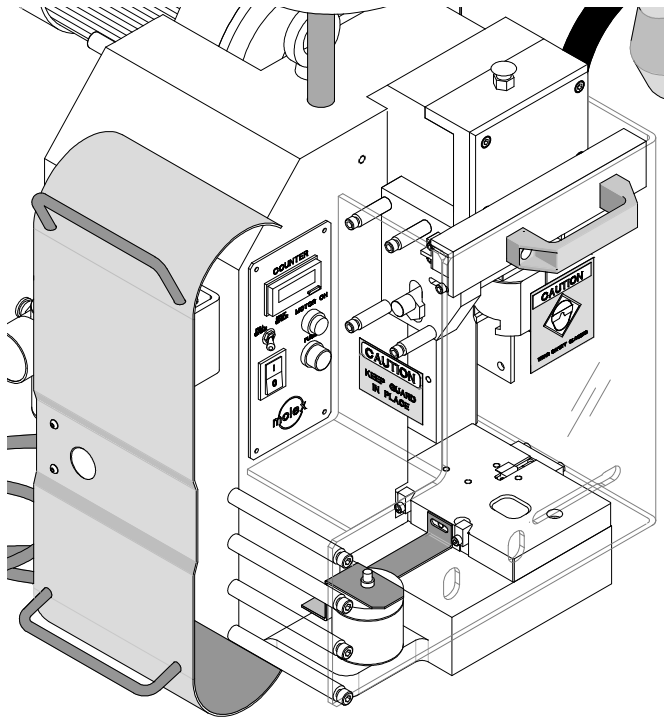

Starting in 2012 all new presses will have the 64016-2595 factory installed.
For existing presses, the 64016-2595 safety guard upgrade kit can be purchased separately.

This document shows the step by step procedure, for installing the upgrade kit.

Installation:

Removing the existing guard.



Always turn off and disconnect the power supply to the press.

Before installing the guards the TM3000 Press will need to be turned off. Use "POWER" switch located on the control panel to turn it off. Refer to the press operation manual TM-638017299.

Tools

To install the 64016-2595 Safety Guard Kit the following tools will be needed.

#3 Phillips Screw Driver

10mm Box Open End Wrench

3mm Allen Wrench

4mm Allen Wrench



1. Before installing the kit become familiar with the upgraded components. See Figure 1.

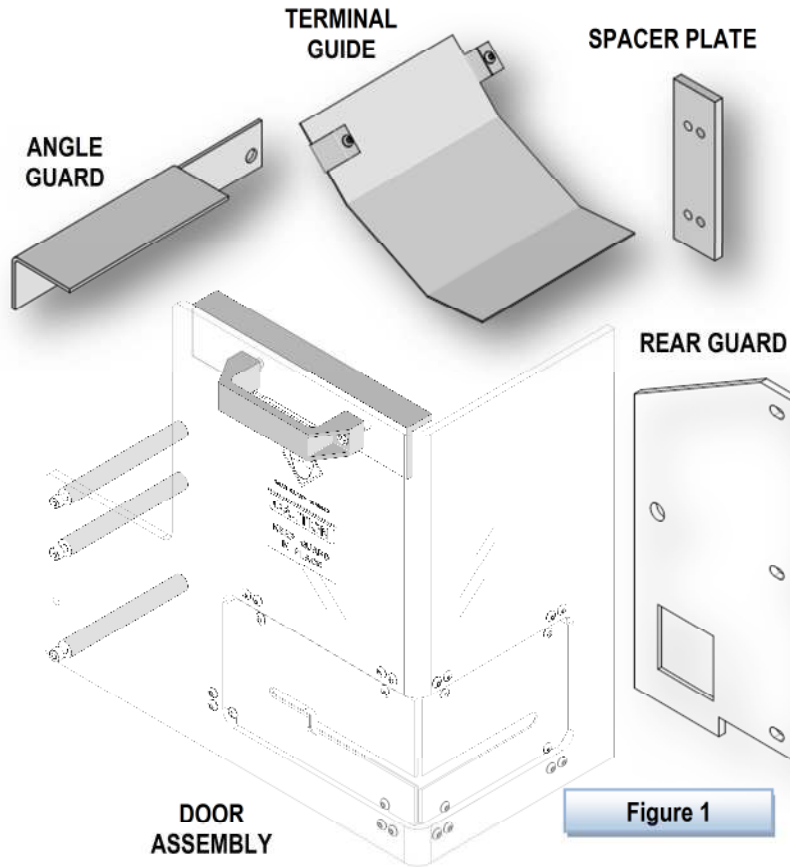

2. Remove the existing door assembly. See Figure 2.

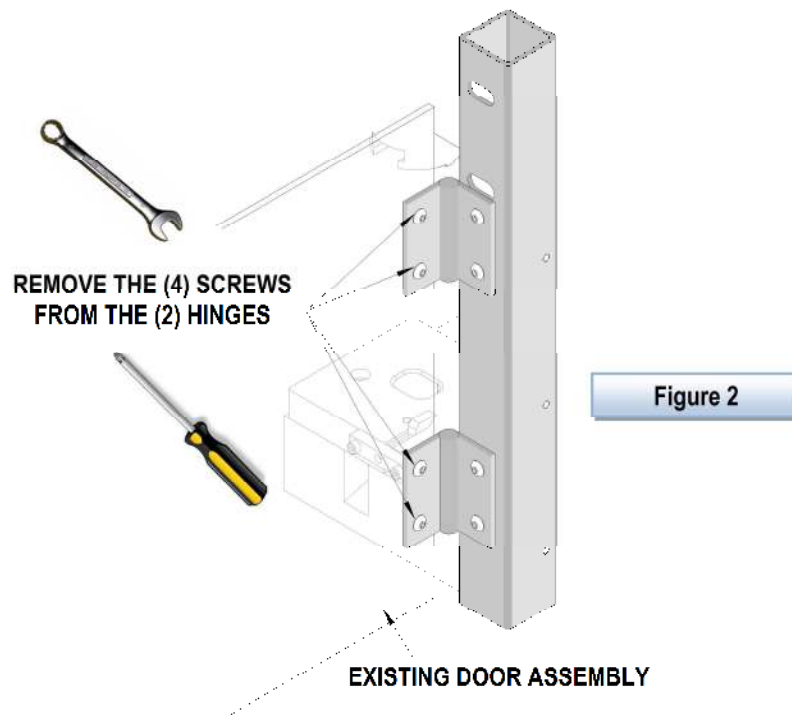

3. Remove the guard mounting frame. See figure 3.

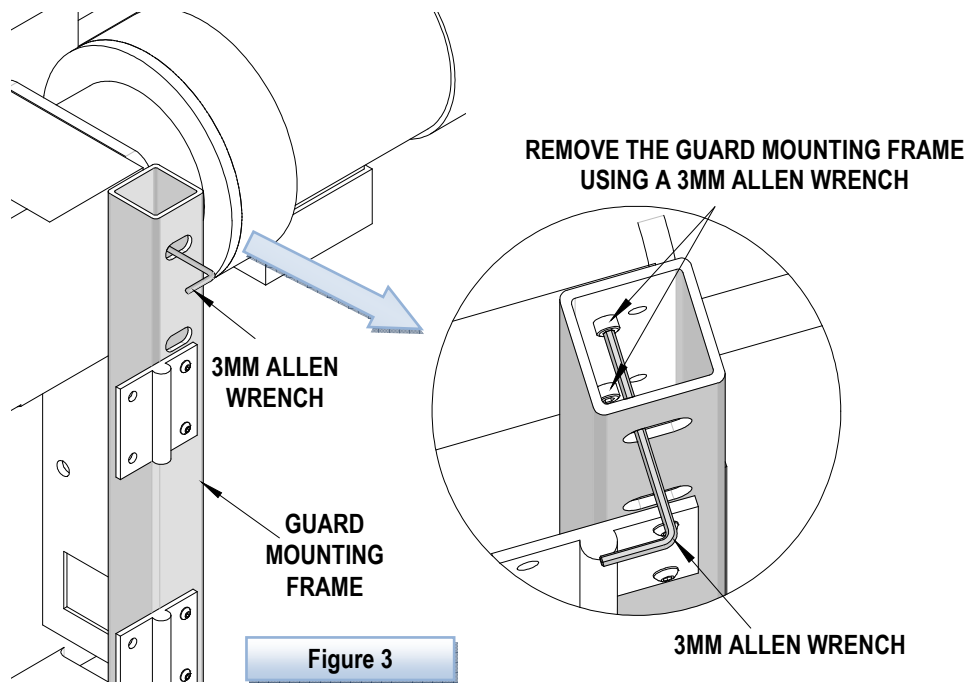

4. Discard the existing shim and existing guard. See figure 4.

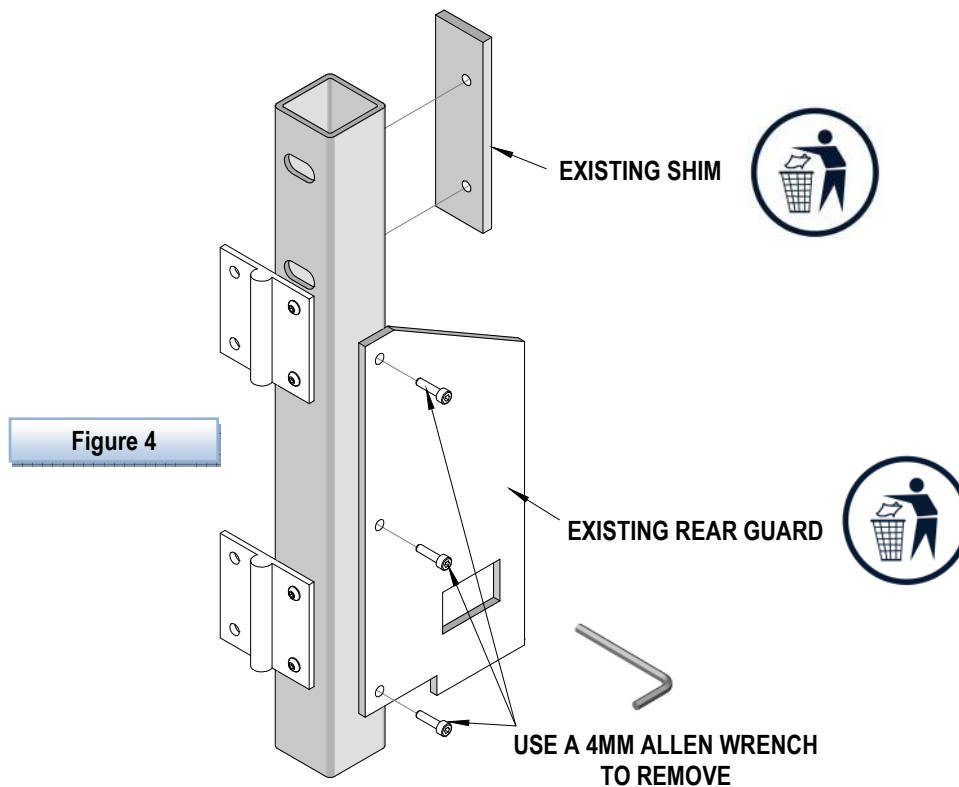

5. Install the new angle guard behind the existing lamp bracket as shown in figure 5.

NOTE: The new angle guard (64016-2581) must be installed to ensure operator safety.

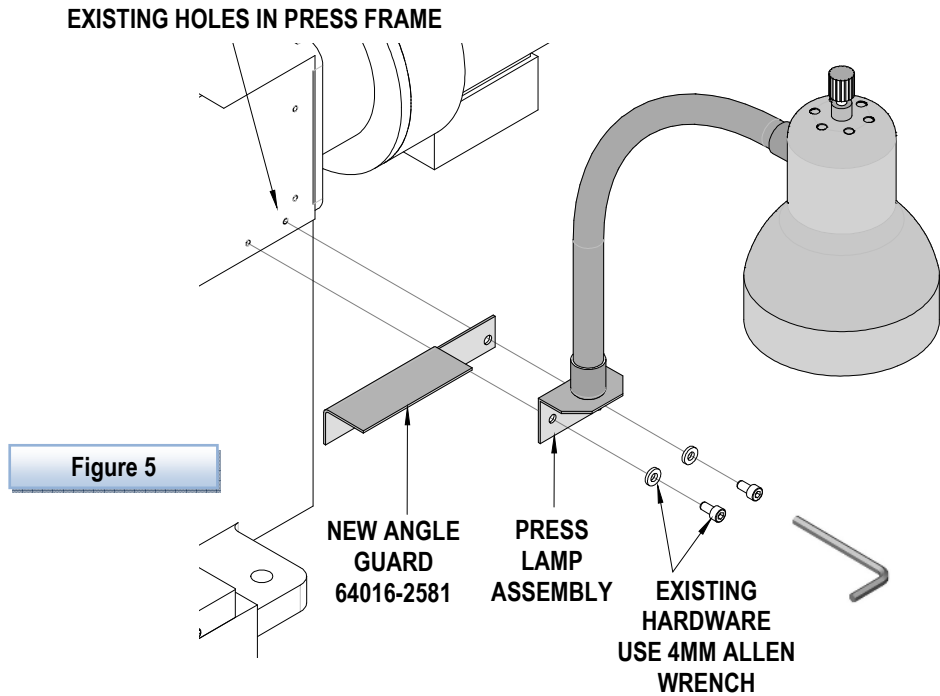

6. Re-attach the guard mounting frame. See Figure 6. Use the left (Front) mounting holes that the guard mounting frame originally used.

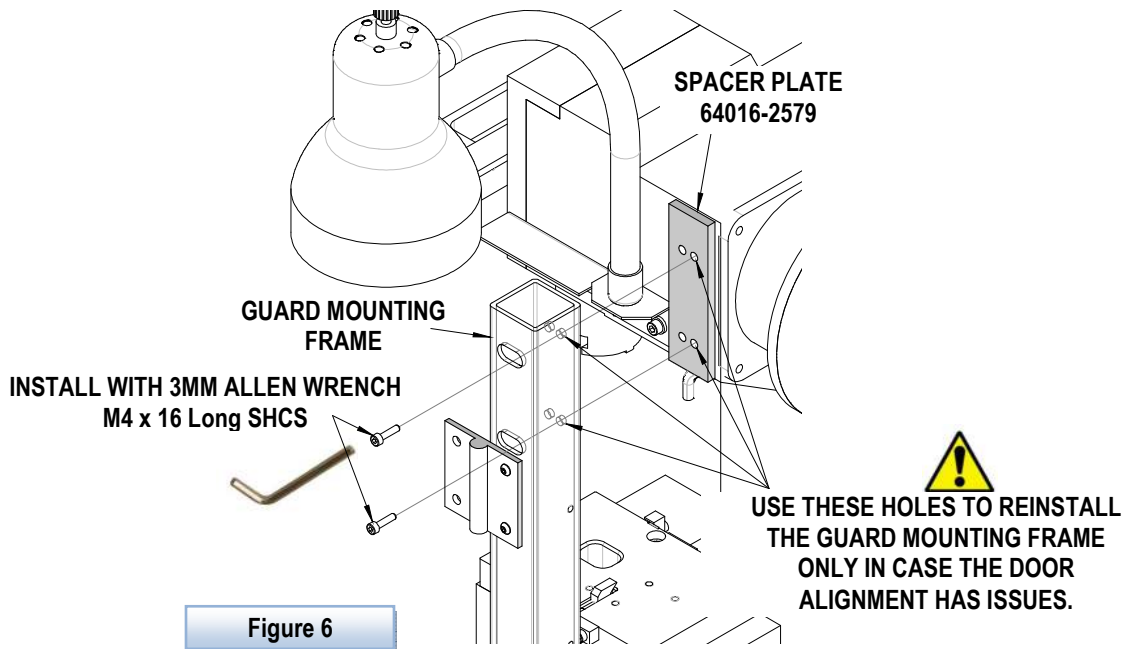

7. Important Locate the new spacer plate (64016-2579) BETWEEN the guard mounting frame and the press.



Note: Make sure to use the RIGHT SIDE set of mounting holes. See Figure 6.

8. Install the new rear guard and the new front door assembly to the hinges. See Figure 7.

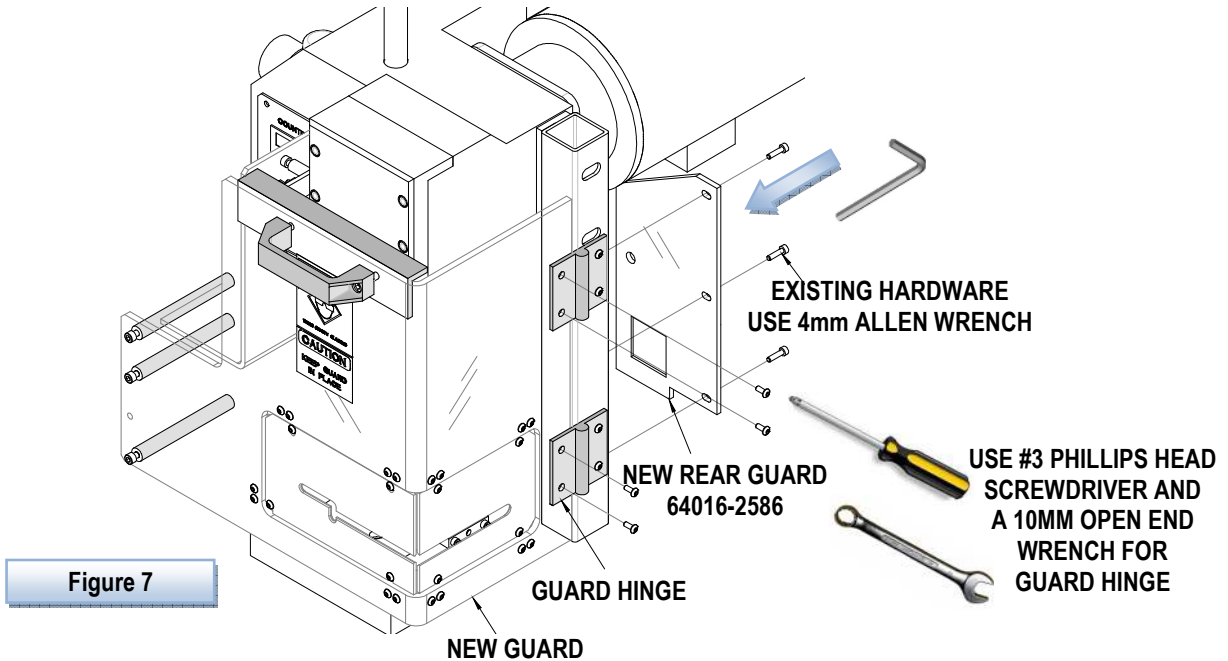

9. Install the lower terminal guide (64016-2522) to the terminal guide (63801-7234) with (2) M4 x 8mm BHCS. See Figure 8.

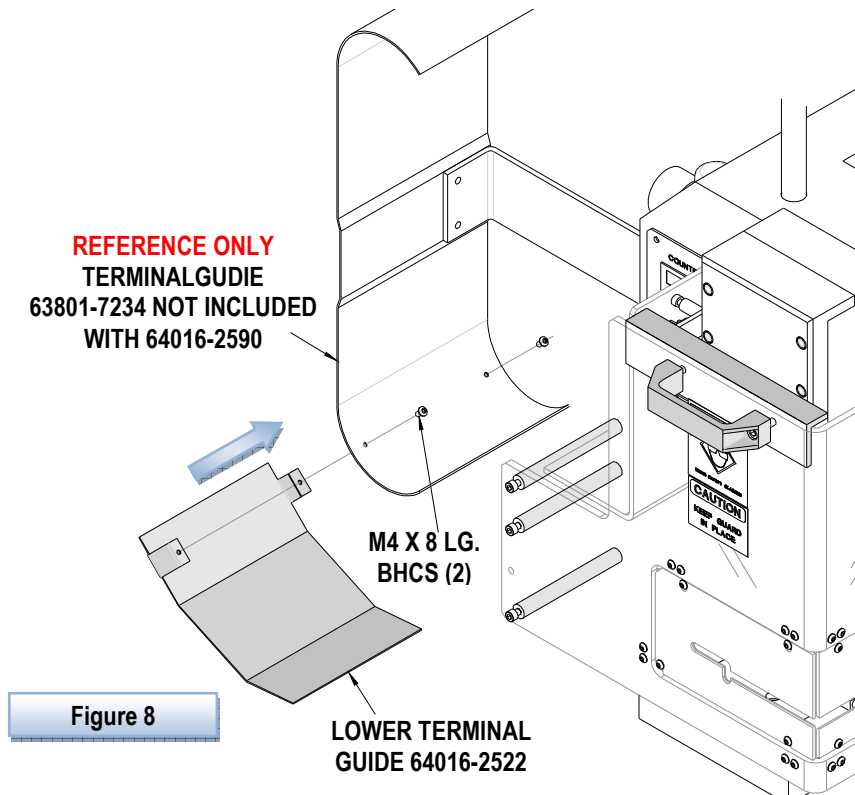

NOTE: Clearance holes may need to be drilled into the existing terminal guide on some older TM3000 presses.

Parts List

Safety Guard Upgrade Kit 64016-2595				
Item No.	Order No.	Engineering No.	Description	Quantity
1	63700-2342	63700-2342	Label-Caution(Eye Glasses)	1
2	63700-2344	63700-2344	Label-Caution(Guard In Place)	1
3	63801-7212	63801-7212	Handle, Guard	1
4	63801-7287	63801-7287	Bracket Guard	1
5	64016-2521	64016-2521	Guard, Front	1
6	64016-2522	64016-2522	Terminal Guide, Lower	1
7	64016-2523	64016-2523	Mounting Bracket	8
8	64016-2537	64016-2537	Guard, Point Of Operation	1
9	64016-2541	64016-2541	Guard, Right	1
10	64016-2579	64016-2579	Spacer Plate	1
11	64016-2581	64016-2581	Guard	1
12	64016-2586	64016-2586	Guard Rear	1
Hardware				
13	N/A	N/A	M4 X 8 Long BHCS	10**
14	N/A	N/A	M4 X 10 Long BHCS	16**
15	N/A	N/A	M6 X 16 Long SHCS	2**
** Available from an industrial supply company such as MSC (1-800-645-7270).				

Assembly

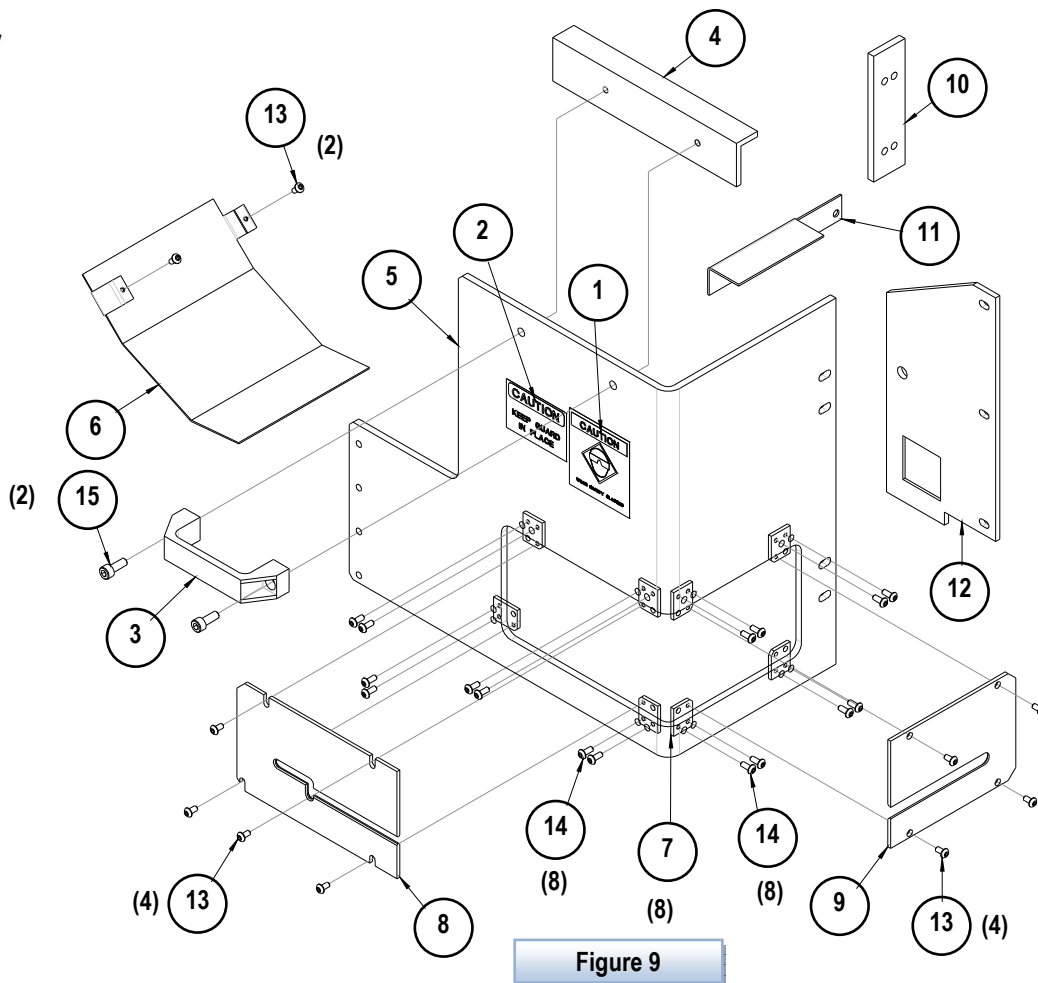

Figure 9

<http://www.molex.com>