



Is Now Part of



**ON Semiconductor®**

To learn more about ON Semiconductor, please visit our website at  
[www.onsemi.com](http://www.onsemi.com)

Please note: As part of the Fairchild Semiconductor integration, some of the Fairchild orderable part numbers will need to change in order to meet ON Semiconductor's system requirements. Since the ON Semiconductor product management systems do not have the ability to manage part nomenclature that utilizes an underscore (\_), the underscore (\_) in the Fairchild part numbers will be changed to a dash (-). This document may contain device numbers with an underscore (\_). Please check the ON Semiconductor website to verify the updated device numbers. The most current and up-to-date ordering information can be found at [www.onsemi.com](http://www.onsemi.com). Please email any questions regarding the system integration to [Fairchild\\_questions@onsemi.com](mailto:Fairchild_questions@onsemi.com).

ON Semiconductor and the ON Semiconductor logo are trademarks of Semiconductor Components Industries, LLC dba ON Semiconductor or its subsidiaries in the United States and/or other countries. ON Semiconductor owns the rights to a number of patents, trademarks, copyrights, trade secrets, and other intellectual property. A listing of ON Semiconductor's product/patent coverage may be accessed at [www.onsemi.com/site/pdf/Patent-Marking.pdf](http://www.onsemi.com/site/pdf/Patent-Marking.pdf). ON Semiconductor reserves the right to make changes without further notice to any products herein. ON Semiconductor makes no warranty, representation or guarantee regarding the suitability of its products for any particular purpose, nor does ON Semiconductor assume any liability arising out of the application or use of any product or circuit, and specifically disclaims any and all liability, including without limitation special, consequential or incidental damages. Buyer is responsible for its products and applications using ON Semiconductor products, including compliance with all laws, regulations and safety requirements or standards, regardless of any support or applications information provided by ON Semiconductor. "Typical" parameters which may be provided in ON Semiconductor data sheets and/or specifications can and do vary in different applications and actual performance may vary over time. All operating parameters, including "Typicals" must be validated for each customer application by customer's technical experts. ON Semiconductor does not convey any license under its patent rights nor the rights of others. ON Semiconductor products are not designed, intended, or authorized for use as a critical component in life support systems or any FDA Class 3 medical devices or medical devices with a same or similar classification in a foreign jurisdiction or any devices intended for implantation in the human body. Should Buyer purchase or use ON Semiconductor products for any such unintended or unauthorized application, Buyer shall indemnify and hold ON Semiconductor and its officers, employees, subsidiaries, affiliates, and distributors harmless against all claims, costs, damages, and expenses, and reasonable attorney fees arising out of, directly or indirectly, any claim of personal injury or death associated with such unintended or unauthorized use, even if such claim alleges that ON Semiconductor was negligent regarding the design or manufacture of the part. ON Semiconductor is an Equal Opportunity/Affirmative Action Employer. This literature is subject to all applicable copyright laws and is not for resale in any manner.



# FOD8332

## Input LED Drive, 2.5 A Output Current, IGBT Drive Optocoupler with Desaturation Detection, Isolated Fault Sensing, and Active Miller Clamp

### Features

- Input LED Drive Facilitates Receiving Digitally Encoded Signals from PWM Output
- Optically Isolated Fault-Sensing Feedback
- Active Miller Clamp to Shut Off IGBT During High  $dv/dt$  without Negative Supply Voltage
- High Noise Immunity Characterized by Common Mode Rejection – 35 kV/ $\mu$ s Minimum,  $V_{CM} = 1500 V_{PEAK}$
- 2.5 A Peak Output Current Driving Capability for Medium Power IGBT
  - P-Channel MOSFETs at Output Stage Enable Output Voltage Swing Close to Supply Rail (Rail-to-Rail Output)
  - Wide Supply Voltage Range: 15 V to 30 V
- Integrated IGBT Protection
  - Desaturation Detection
  - “Soft” IGBT Turn-Off
  - Under-Voltage Lockout (UVLO) with Hysteresis
- Fast Switching Speed Over Full Operating Temperature Range
  - 250 ns Maximum Propagation Delay
  - 100 ns Maximum Pulse Width Distortion
- Extended Industrial Temperature Range:
  - $-40^{\circ}\text{C}$  to  $100^{\circ}\text{C}$
- Safety and Regulatory Approvals
  - UL1577, 4,243  $V_{RMS}$  for 1 Minute
  - DIN-EN/IEC60747-5-5:
    - 1,414  $V_{PEAK}$  Working Insulation Voltage Rating
    - 8,000  $V_{PEAK}$  Transient Isolation Voltage Rating
- 8 mm Creepage and Clearance Distances

### Applications

- AC and Brushless DC Motor Drive
- Industrial Inverter
- Uninterruptible Power Supply
- Induction Heating
- Isolated IGBT/Power MOSFET Gate Drive

### Description

The FOD8332 is an advanced 2.5 A output current IGBT drive optocoupler capable of driving medium-power IGBTs with ratings up to 1,200 V and 150 A. It is suited for fast-switching driving of power IGBTs and MOSFETs in motor-control inverter applications and high-performance power systems. The FOD8332 offers protection features necessary for preventing fault conditions that lead to destructive thermal runaway of IGBTs.

The device utilizes Fairchild’s proprietary Optoplanar<sup>®</sup> coplanar packaging technology and optimized IC design to achieve reliable high isolation and high noise immunity, characterized by high common-mode rejection and power supply rejection specifications. The device is housed in a wide-body, 16-pin, small-outline, plastic package.

The gate-driver channel consists of an aluminum gallium arsenide (AlGaAs) light-emitting diode (LED) optically coupled to an integrated high-speed driver circuit with a low- $R_{DS(ON)}$  MOSFET output stage. The fault-sense channel consists of an AlGaAs LED optically coupled to an integrated high-speed feedback circuit for fault sensing.

### Related Resources

- [FOD8316—2.5 A Output Current, IGBT Drive Optocoupler with Desaturation, Isolated Fault Sensing](#)
- [FOD8318—2.5 A Output Current, IGBT Drive Optocoupler with Active Miller Clamp, Desaturation Detection, and Isolated Fault Sensing](#)
- [FOD8333 – Input LED Drive, 2.5 A Output Current, IGBT Drive Optocoupler with Desaturation Detection, Isolated Fault Sensing, Active Miller Clamp, and Automatic Fault Reset](#)
- [AN-3009—Standard Gate-Driver Optocouplers](#)
- [www.fairchildsemi.com/search/tree/optoelectronics/](http://www.fairchildsemi.com/search/tree/optoelectronics/)

## Truth Table

| LED | UVLO ( $V_{DD} - V_E$ ) | DESAT Detected? | FAULT <sup>(1)</sup> | $V_O$ |
|-----|-------------------------|-----------------|----------------------|-------|
| X   | Active                  | X               | HIGH                 | LOW   |
| On  | Not Active              | Yes             | LOW                  | LOW   |
| Off | X                       | X               | HIGH                 | LOW   |
| On  | Not Active              | No              | HIGH                 | HIGH  |

### Note:

1. FAULT pin is connected to a pull-up resistor.

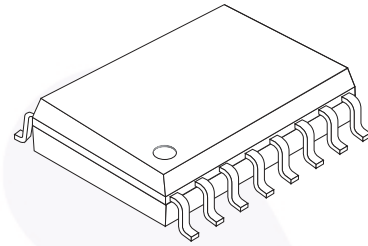
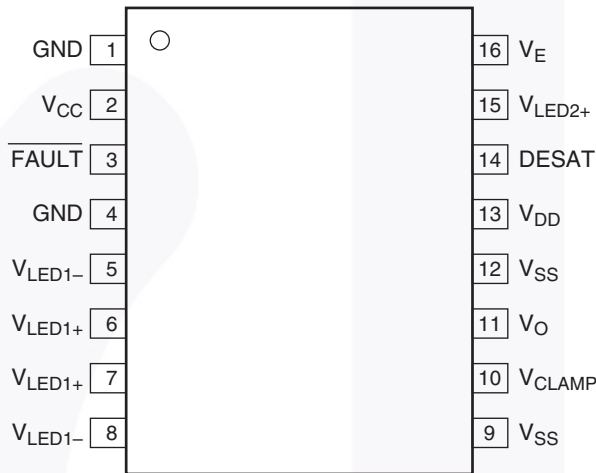


Figure 2. Pin Configuration

## Pin Definitions

| Pin # | Name        | Description                                                       |
|-------|-------------|-------------------------------------------------------------------|
| 1     | GND         | Ground for Fault-Sense Optocoupler                                |
| 2     | $V_{CC}$    | Positive Supply Voltage (3 V to 15 V) for Fault Sense Optocoupler |
| 3     | FAULT       | Fault-Sense Output                                                |
| 4     | GND         | Ground for Fault-Sense Optocoupler                                |
| 5     | $V_{LED1-}$ | LED1 Cathode                                                      |
| 6     | $V_{LED1+}$ | LED1 Anode                                                        |
| 7     | $V_{LED1+}$ | LED1 Anode                                                        |
| 8     | $V_{LED1-}$ | LED1 Cathode                                                      |
| 9     | $V_{SS}$    | Negative Output Supply Voltage                                    |
| 10    | $V_{CLAMP}$ | Clamp Supply Voltage                                              |
| 11    | $V_O$       | Gate-Drive Output Voltage                                         |
| 12    | $V_{SS}$    | Negative Output Supply Voltage                                    |
| 13    | $V_{DD}$    | Positive Output Supply Voltage                                    |
| 14    | DESAT       | Desaturation Voltage Input                                        |
| 15    | $V_{LED2+}$ | LED2 Anode (Do not connect. Leave floating.)                      |
| 16    | $V_E$       | Output Supply Voltage/IGBT Emitter                                |

### Block Diagram

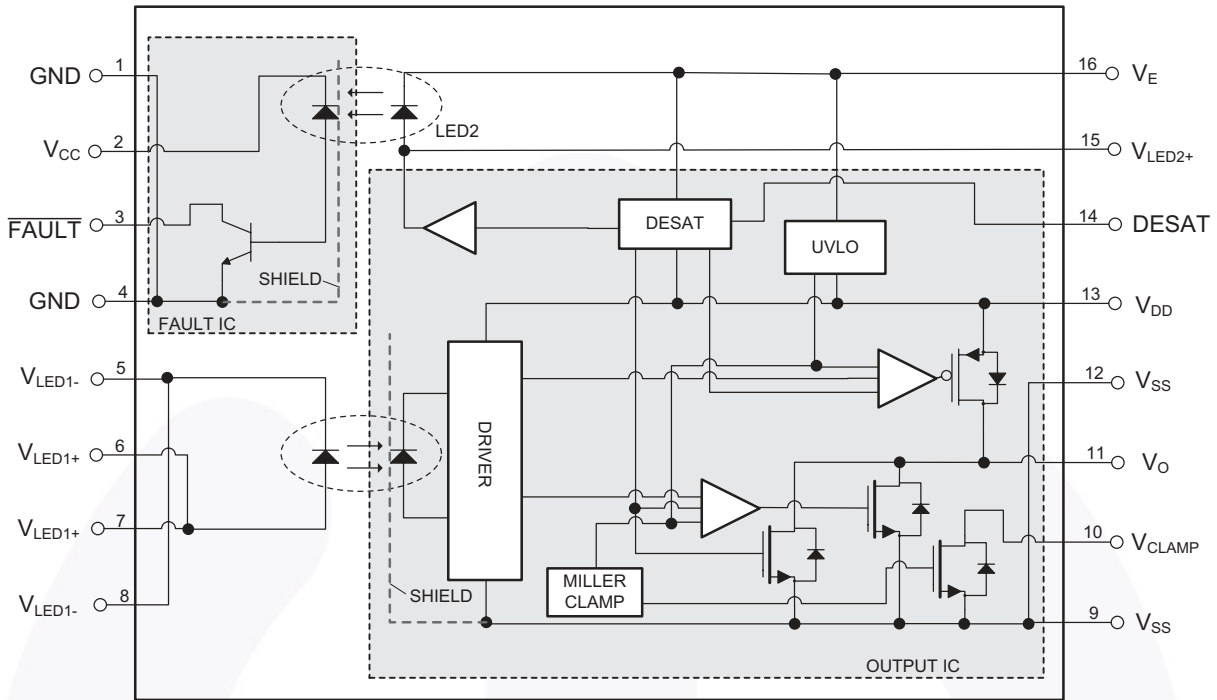


Figure 3. Functional Block Diagram

## Safety and Insulation Ratings

As per DIN EN/IEC 60747-5-5, this optocoupler is suitable for “safe electrical insulation” only within the safety limit data. Compliance with the safety ratings must be ensured by means of protective circuits.

| Symbol                | Parameter                                                                                                                                                      | Min.            | Typ.      | Max. | Unit              |
|-----------------------|----------------------------------------------------------------------------------------------------------------------------------------------------------------|-----------------|-----------|------|-------------------|
|                       | Installation Classifications per DIN VDE 0110/1.89 Table 1                                                                                                     |                 |           |      |                   |
|                       | Rated Mains Voltage < 150 V <sub>RMS</sub>                                                                                                                     |                 | I–IV      |      |                   |
|                       | Rated Mains Voltage < 300 V <sub>RMS</sub>                                                                                                                     |                 | I–IV      |      |                   |
|                       | Rated Mains Voltage < 450 V <sub>RMS</sub>                                                                                                                     |                 | I–IV      |      |                   |
|                       | Rated Mains Voltage < 600 V <sub>RMS</sub>                                                                                                                     |                 | I–IV      |      |                   |
|                       | Rated Mains Voltage < 1000 V <sub>RMS</sub>                                                                                                                    |                 | I–III     |      |                   |
|                       | Climatic Classification                                                                                                                                        |                 | 40/100/21 |      |                   |
|                       | Pollution Degree (DIN VDE 0110/1.89)                                                                                                                           |                 | 2         |      |                   |
| CTI                   | Comparative Tracking Index (DIN IEC 112/VDE 0303 Part 1)                                                                                                       | 175             |           |      |                   |
| V <sub>PR</sub>       | Input-to-Output Test Voltage, Method b, V <sub>IORM</sub> × 1.875 = V <sub>PR</sub> , 100% Production Test with t <sub>m</sub> = 1 s, Partial Discharge < 5 pC | 2651            |           |      | V <sub>peak</sub> |
|                       | Input-to-Output Test Voltage, Method a, V <sub>IORM</sub> × 1.6 = V <sub>PR</sub> , Type and Sample Test with t <sub>m</sub> = 10 s, Partial Discharge < 5 pC  | 2262            |           |      | V <sub>peak</sub> |
| V <sub>IORM</sub>     | Maximum Working Insulation Voltage                                                                                                                             | 1414            |           |      | V <sub>peak</sub> |
| V <sub>IOTM</sub>     | Highest Allowable Over Voltage                                                                                                                                 | 8000            |           |      | V <sub>peak</sub> |
|                       | External Creepage                                                                                                                                              | 8.0             |           |      | mm                |
|                       | External Clearance                                                                                                                                             | 8.0             |           |      | mm                |
|                       | Insulation Thickness                                                                                                                                           | 0.5             |           |      | mm                |
| T <sub>Case</sub>     | Safety Limit Values – Maximum Values in Failure;<br>Case Temperature                                                                                           | 150             |           |      | °C                |
| P <sub>S,INPUT</sub>  | Safety Limit Values – Maximum Values in Failure;<br>Input Power                                                                                                | 100             |           |      | mW                |
| P <sub>S,OUTPUT</sub> | Safety Limit Values – Maximum Values in Failure;<br>Output Power                                                                                               | 600             |           |      | mW                |
| R <sub>IO</sub>       | Insulation Resistance at T <sub>S</sub> , V <sub>IO</sub> = 500 V                                                                                              | 10 <sup>9</sup> |           |      | Ω                 |

## Absolute Maximum Ratings

Stresses exceeding the absolute maximum ratings may damage the device. The device may not function or be operable above the recommended operating conditions and stressing the parts to these levels is not recommended. In addition, extended exposure to stresses above the recommended operating conditions may affect device reliability. The absolute maximum ratings are stress ratings only.  $T_A = 25^\circ\text{C}$  unless otherwise specified.

| Symbol                     | Parameter                                                                                                              | Value                           | Units            |
|----------------------------|------------------------------------------------------------------------------------------------------------------------|---------------------------------|------------------|
| $T_{STG}$                  | Storage Temperature                                                                                                    | -40 to +125                     | $^\circ\text{C}$ |
| $T_{OPR}$                  | Operating Temperature                                                                                                  | -40 to +100                     | $^\circ\text{C}$ |
| $T_J$                      | Junction Temperature                                                                                                   | -40 to +125                     | $^\circ\text{C}$ |
| $T_{SOL}$                  | Lead Solder Temperature<br>(not certified for wave immersion)<br><i>Refer to reflow temperature profile on page 31</i> | 260 for 10 s                    | $^\circ\text{C}$ |
| $PD_I$                     | Input Power Dissipation <sup>(2)(3)</sup>                                                                              | 45                              | mW               |
| $PD_O$                     | Output Power Dissipation <sup>(3)(4)</sup>                                                                             | 600                             | mW               |
| <b>Gate Drive Channel</b>  |                                                                                                                        |                                 |                  |
| $I_{F(AVG)}$               | Average Input Current                                                                                                  | 25                              | mA               |
| $I_{F(PEAK)}$              | Peak Transient Forward Current<br>(Pulse Width < 1 $\mu\text{s}$ )                                                     | 1.0                             | A                |
| $I_{OH(PEAK)}$             | Peak Output High Current <sup>(5)</sup>                                                                                | 3.0                             | A                |
| $I_{OL(PEAK)}$             | Peak Output Low Current <sup>(5)</sup>                                                                                 | 3.0                             | A                |
| $V_R$                      | Reverse Input Voltage                                                                                                  | 5.0                             | V                |
| $V_E - V_{SS}$             | Negative Output Supply Voltage <sup>(6)</sup>                                                                          | -0.5 to 15                      | V                |
| $V_{DD} - V_E$             | Positive Output Supply Voltage                                                                                         | -0.5 to 35 - ( $V_E - V_{SS}$ ) | V                |
| $V_{O(PEAK)} - V_{SS}$     | Gate Drive Output Voltage                                                                                              | -0.5 to 35                      | V                |
| $V_{DD} - V_{SS}$          | Output Supply Voltage                                                                                                  | -0.5 to 35                      | V                |
| $V_{DESAT}$                | Desaturation Voltage                                                                                                   | $V_E$ to $V_E + 25$             | V                |
| $I_{DESAT}$                | Desaturation Current                                                                                                   | 60                              | mA               |
| $V_{CLAMP} - V_{SS}$       | Active Miller Clamping Voltage                                                                                         | -0.5 to 35                      | V                |
| $I_{CLAMP}$                | Peaking Clamping Sinking Current                                                                                       | 1.7                             | A                |
| $t_{R(IN)}, t_{F(IN)}$     | Input Signal Rise and Fall Time                                                                                        | 500                             | ns               |
| <b>Fault Sense Channel</b> |                                                                                                                        |                                 |                  |
| $V_{CC}$                   | Positive Input Supply Voltage                                                                                          | -0.5 to 20                      | V                |
| $V_{\overline{FAULT}}$     | $\overline{FAULT}$ Output Voltage                                                                                      | -0.5 to 20                      | V                |
| $I_{\overline{FAULT}}$     | $\overline{FAULT}$ Output Current                                                                                      | 16.0                            | mA               |

### Notes:

- No derating required across temperature range.
- Functional operation under these conditions is not implied. Permanent damage may occur if the device is subjected to conditions outside these ratings.
- Derate linearly above  $25^\circ\text{C}$ , free air temperature at a rate of  $6.2 \text{ mW}/^\circ\text{C}$ .
- Maximum pulse width = 10  $\mu\text{s}$ .
- This negative output supply voltage is optional. It is only needed when negative gate drive is implemented.

## Recommended Operating Conditions

The Recommended Operating Conditions table defines the conditions for actual device operation. Recommended operating conditions are specified to ensure optimal performance to the datasheet specifications. Fairchild does not recommend exceeding them or designing to absolute maximum ratings.

| Symbol            | Parameter                                     | Min. | Max.                  | Unit |
|-------------------|-----------------------------------------------|------|-----------------------|------|
| $T_A$             | Ambient Operating Temperature                 | -40  | +100                  | °C   |
| $I_{F(ON)}$       | Input Current (ON)                            | 7    | 16                    | mA   |
| $V_{F(OFF)}$      | Input Voltage (OFF)                           | -3.6 | 0.8                   | V    |
| $V_{CC}$          | Supply Voltage                                | 3    | 15                    | V    |
| $V_{DD} - V_{SS}$ | Total Output Supply Voltage                   | 15   | 30                    | V    |
| $V_{DD} - V_E$    | Positive Output Supply Voltage <sup>(7)</sup> | 15   | $30 - (V_E - V_{SS})$ | V    |
| $V_E - V_{SS}$    | Negative Output Supply Voltage                | 0    | 15                    | V    |
| $t_{PW}$          | Input Pulse Width                             | 500  |                       | ns   |

### Note:

7. During power up or down, ensure that both the input and output supply voltages reach the proper recommended operating voltages to avoid any momentary instability at the output state.

## Isolation Characteristics

Apply over all recommended conditions; typical value is measured at  $T_A = 25^\circ\text{C}$ .

| Symbol    | Parameter                      | Conditions                                                                                                                           | Min.  | Typ.      | Max. | Units     |
|-----------|--------------------------------|--------------------------------------------------------------------------------------------------------------------------------------|-------|-----------|------|-----------|
| $V_{ISO}$ | Input-Output Isolation Voltage | $T_A = 25^\circ\text{C}$ , Relative Humidity < 50%,<br>$t = 1.0$ minute, $I_{I-O} \leq 10 \mu\text{A}$ , 50 Hz <sup>(8)(9)(10)</sup> | 4,243 |           |      | $V_{RMS}$ |
| $R_{ISO}$ | Isolation Resistance           | $V_{I-O} = 500 \text{ V}^{(8)}$                                                                                                      |       | $10^{11}$ |      |           |
| $C_{ISO}$ | Isolation Capacitance          | $V_{I-O} = 0 \text{ V}$ , Frequency = 1.0 MHz <sup>(8)</sup>                                                                         |       | 1         |      | pF        |

### Notes:

8. Device is considered a two-terminal device: pins 1 to 8 are shorted together and pins 9 to 16 are shorted together.
9. 4,243  $V_{RMS}$  for 1-minute duration is equivalent to 5,091  $V_{RMS}$  for 1-second duration.
10. The input-output isolation voltage is a dielectric voltage rating per UL1577. It should not be regarded as an input-output continuous voltage rating. For the continuous working voltage rating, refer to equipment-level safety specification or DIN EN/IEC 60747-5-5 Safety and Insulation Ratings Table on page 4.

## Electrical Characteristics

Apply over all recommended conditions; typical value is measured at  $V_{CC} = 5\text{ V}$ ,  $V_{DD} - V_{SS} = 30\text{ V}$ ,  $V_E - V_{SS} = 0\text{ V}$ , and  $T_A = 25^\circ\text{C}$ ; unless otherwise specified.

| Symbol                    | Parameter                                       | Conditions                                                      | Min.           | Typ.           | Max.  | Units | Figure        |
|---------------------------|-------------------------------------------------|-----------------------------------------------------------------|----------------|----------------|-------|-------|---------------|
| <b>Gate Drive Channel</b> |                                                 |                                                                 |                |                |       |       |               |
| $V_F$                     | Input Forward Voltage                           | $I_F = 10\text{ mA}$                                            | 1.10           | 1.45           | 1.80  | V     | 5             |
| $\Delta(V_F/T_A)$         | Temperature Coefficient of Forward Voltage      |                                                                 |                | -1.5           |       | mV/°C |               |
| $BV_R$                    | Input Reverse Breakdown Voltage                 | $I_R = 10\text{ }\mu\text{A}$                                   | 5              |                |       | V     |               |
| $C_{IN}$                  | Input Capacitance                               | $f = 1\text{ MHz}$ , $V_F = 0\text{ V}$                         |                | 60             |       | pF    |               |
| $I_{FLH}$                 | Threshold Input Current, Low-to-High            | $I_O = 0\text{ mA}$ , $V_O > 5\text{ V}$                        |                | 2.5            | 7.0   | mA    | 30            |
| $V_{FHL}$                 | Threshold Input Voltage, High-to-Low            | $I_O = 0\text{ mA}$ , $V_O < 5\text{ V}$                        | 0.8            |                |       | V     | 31            |
| $I_{OH}$                  | High Level Output Current                       | $V_O = V_{DD} - 3\text{ V}$ ,<br>$I_F = 10\text{ mA}$           | -1.0           | -2.5           |       | A     | 6, 10,<br>32  |
|                           |                                                 | $V_O = V_{DD} - 6\text{ V}$ ,<br>$I_F = 10\text{ mA}^{(11)}$    | -2.5           |                |       | A     |               |
| $I_{OL}$                  | Low Level Output Current                        | $V_O = V_{SS} + 3\text{ V}$ , $I_F = 0\text{ mA}$               | 1              | 3              |       | A     | 7, 11,<br>33  |
|                           |                                                 | $V_O = V_{SS} + 6\text{ V}$ ,<br>$I_F = 0\text{ mA}^{(12)}$     | 2.5            |                |       | A     |               |
| $I_{OLF}$                 | Low Level Output Current During Fault Condition | $V_O - V_{SS} = 14\text{ V}$                                    | 70             | 125            | 170   | mA    | 34            |
| $V_{OH}$                  | High Level Output Voltage                       | $I_F = 10\text{ mA}$ ,<br>$I_O = -100\text{ mA}^{(13)(14)(15)}$ | $V_{DD} - 1.0$ | $V_{DD} - 0.2$ |       | V     | 8, 10,<br>35  |
| $V_{OL}$                  | Low Level Output Voltage                        | $I_F = 0\text{ mA}$ , $I_O = 100\text{ mA}$                     |                | 0.1            | 0.5   | V     | 9, 11,<br>36  |
| $I_{DDH}$                 | High Level Supply Current                       | $V_O = \text{Open}^{(15)}$ , $I_O = 0\text{ mA}$                |                | 2.5            | 5.0   | mA    | 12, 13,<br>37 |
| $I_{DDL}$                 | Low Level Supply Current                        | $V_O = \text{Open}$ , $I_O = 0\text{ mA}$                       |                | 2.5            | 5.0   | mA    | 12, 13,<br>38 |
| $I_{EL}$                  | $V_E$ Low Level Supply Current                  |                                                                 | -0.8           | -0.5           |       | mA    | 38            |
| $I_{EH}$                  | $V_E$ High Level Supply Current                 |                                                                 | -0.50          | -0.25          |       | mA    | 37            |
| $I_{CHG}$                 | Blanking Capacitor Charge Current               | $V_{DESAT} = 2\text{ V}^{(15)(16)}$                             | -0.33          | -0.25          | -0.13 | mA    | 14, 39        |
| $I_{DSCHG}$               | Blanking Capacitor Discharge Current            | $V_{DESAT} = 7\text{ V}$                                        | 10             | 40             |       | mA    | 39            |
| $V_{UVLO+}$               | Under-Voltage Lockout Threshold <sup>(14)</sup> | $I_F = 10\text{ mA}$ , $V_O > 5\text{ V}$                       | 10.8           | 11.7           | 12.7  | V     | 40            |
| $V_{UVLO-}$               |                                                 | $I_F = 10\text{ mA}$ , $V_O < 5\text{ V}$                       | 9.8            | 10.7           | 11.7  | V     |               |
| $UVLO_{HYS}$              | Under-Voltage Lockout Threshold Hysteresis      |                                                                 |                | 1.0            |       | V     |               |
| $V_{DESAT}$               | DESAT Threshold <sup>(14)</sup>                 | $V_{DD} - V_E > V_{ULVO-}$                                      | 6.0            | 6.5            | 7.2   | V     | 15, 39        |
| $V_{CLAMP\_THRES}$        | Clamping Threshold Voltage                      |                                                                 |                | 2.0            |       | V     | 41            |
| $I_{CLAMPL}$              | Clamp Low Level Sinking Current                 | $V_O = V_{SS} + 2.5\text{ V}$                                   | 0.35           | 1.10           |       | A     | 16, 42        |



## Electrical Characteristics (Continued)

Apply over all recommended conditions; typical value is measured at  $V_{CC} = 5\text{ V}$ ,  $V_{DD} - V_{SS} = 30\text{ V}$ ,  $V_E - V_{SS} = 0\text{ V}$ , and  $T_A = 25^\circ\text{C}$ ; unless otherwise specified.

| Symbol                         | Parameter                                           | Conditions                                                                                           | Min. | Typ.   | Max. | Units         | Figure |
|--------------------------------|-----------------------------------------------------|------------------------------------------------------------------------------------------------------|------|--------|------|---------------|--------|
| <b>Fault Feedback Channel</b>  |                                                     |                                                                                                      |      |        |      |               |        |
| $I_{CCH}$                      | $\overline{\text{FAULT}}$ High Level Supply Current | $I_{F2} = 0\text{ mA}$ ,<br>$V_{\overline{\text{FAULT}}} = \text{Open}$ ,<br>$V_{CC} = 15\text{ V}$  |      | 0.0004 | 2    | $\mu\text{A}$ | 43     |
| $I_{CCL}$                      | $\overline{\text{FAULT}}$ Low Level Supply Current  | $I_{F2} = 16\text{ mA}$ ,<br>$V_{\overline{\text{FAULT}}} = \text{Open}$ ,<br>$V_{CC} = 15\text{ V}$ |      | 150    | 200  | $\mu\text{A}$ | 44     |
| $I_{\overline{\text{FAULTH}}}$ | $\overline{\text{FAULT}}$ Logic High Output Current | $V_{\overline{\text{FAULT}}} = V_{CC} = 5.5\text{ V}$                                                |      | 0.02   | 0.50 | $\mu\text{A}$ | 45     |
| $I_{\overline{\text{FAULTL}}}$ | $\overline{\text{FAULT}}$ Logic Low Output Current  | $V_{\overline{\text{FAULT}}} = 0.4\text{ V}$ ,<br>$V_{CC} = 5.5\text{ V}$                            | 1.1  |        |      | $\text{mA}$   | 17, 46 |

### Notes:

11. Maximum pulse width = 10  $\mu\text{s}$ , maximum duty cycle = 0.2%.
12. Minimum pulse width = 4.99 ms, minimum duty cycle = 99.8%.
13.  $V_{OH}$  is measured with the DC load current in this testing (maximum pulse width = 1 ms, maximum duty cycle = 20%). When driving capacitive loads,  $V_{OH}$  approaches  $V_{DD}$  as  $I_{OH}$  approaches zero units.
14. Positive output supply voltage ( $V_{DD} - V_E$ ) should be at least 15 V to ensure adequate margin in excess of the maximum under-voltage lockout threshold,  $V_{UVLO+}$ , of 12.7 V.
15. When  $V_{DD} - V_E > V_{UVLO}$  and the output state  $V_O$  is allowed to go HIGH, the DESAT-detection feature is active and provides the primary source of IGBT protection. UVLO is needed to ensure DESAT detection is functional.
16. The blanking time,  $t_{BLANK}$ , is adjustable by an external capacitor ( $C_{BLANK}$ ), where  $t_{BLANK} = C_{BLANK} \times (V_{DESAT} / I_{CHG})$ .

## Switching Characteristics

Apply over all recommended conditions; typical value is measured at  $V_{CC} = 5\text{ V}$ ,  $V_{DD} - V_{SS} = 30\text{ V}$ ,  $V_E - V_{SS} = 0\text{ V}$ , and  $T_A = 25^\circ\text{C}$ ; unless otherwise specified.

| Symbol             | Parameter                                                                                             | Conditions                                                                                                                                                                                                               | Min. | Typ. | Max. | Units                   | Figure             |
|--------------------|-------------------------------------------------------------------------------------------------------|--------------------------------------------------------------------------------------------------------------------------------------------------------------------------------------------------------------------------|------|------|------|-------------------------|--------------------|
| $t_{PHL}$          | Propagation Delay to Logic Low Output <sup>(18)</sup>                                                 | $R_g = 10\ \Omega$ , $C_g = 10\ \text{nF}$ ,<br>$f = 10\ \text{kHz}$ ,<br>Duty Cycle = 50%,<br>$I_F = 10\ \text{mA}$ ,<br>$V_{DD} - V_{SS} = 30\ \text{V}$ <sup>(17)</sup>                                               | 100  | 135  | 250  | ns                      | 18, 19, 20, 21, 47 |
| $t_{PLH}$          | Propagation Delay to Logic High Output <sup>(19)</sup>                                                |                                                                                                                                                                                                                          | 100  | 150  | 250  | ns                      |                    |
| PWD                | Pulse Width Distortion, $ t_{PHL} - t_{PLH} $ <sup>(20)</sup>                                         |                                                                                                                                                                                                                          | 15   | 100  | ns   | 47                      |                    |
| PDD Skew           | Propagation Delay Difference Between Any Two Parts or Channels, $(t_{PHL} - t_{PLH})$ <sup>(21)</sup> |                                                                                                                                                                                                                          | -150 | 150  | ns   |                         |                    |
| $t_R$              | Output Rise Time (10% to 90%)                                                                         |                                                                                                                                                                                                                          | 50   | ns   | 47   |                         |                    |
| $t_F$              | Output Fall Time (90% to 10%)                                                                         |                                                                                                                                                                                                                          | 50   | ns   |      |                         |                    |
| $t_{DESAT(LOW)}$   | DESAT Sense to DESAT Low Propagation Delay <sup>(24)</sup>                                            | $R_g = 10\ \Omega$ , $C_g = 10\ \text{nF}$ ,<br>$V_{DD} - V_{SS} = 30\ \text{V}$<br>$(C_{DESAT} = 100\ \text{pF}$ ,<br>$R_F = 4.7\ \text{k}\Omega$ , $V_{CC} = 5.5\ \text{V})$                                           | 0.25 |      |      | $\mu\text{s}$           |                    |
| $t_{DESAT(90\%)}$  | DESAT Sense to 90% $V_O$ Delay <sup>(22)</sup>                                                        |                                                                                                                                                                                                                          | 0.45 | 0.70 |      | $\mu\text{s}$           | 22, 48             |
| $t_{DESAT(10\%)}$  | DESAT Sense to 10% $V_O$ Delay <sup>(22)</sup>                                                        |                                                                                                                                                                                                                          | 2.8  | 4.0  |      | $\mu\text{s}$           | 23, 24, 25, 48     |
| $t_{DESAT(FAULT)}$ | DESAT Sense to Low Level FAULT Signal Delay <sup>(23)</sup>                                           |                                                                                                                                                                                                                          | 0.5  | 1.5  |      | $\mu\text{s}$           | 26, 48             |
| $t_{RESET(FAULT)}$ | RESET to High Level FAULT Signal Delay <sup>(25)</sup>                                                |                                                                                                                                                                                                                          | 0.5  | 2.3  | 4.5  | $\mu\text{s}$           | 27, 48             |
| $t_{DESAT(MUTE)}$  | DESAT Input Mute                                                                                      |                                                                                                                                                                                                                          | 10.0 | 22.0 | 35.0 | $\mu\text{s}$           | 48                 |
| $t_{UVLO\ ON}$     | UVLO Turn-On Delay <sup>(26)</sup>                                                                    | $V_{DD} = 20\ \text{V}$ in 1.0 ms Ramp                                                                                                                                                                                   | 4.0  |      |      | $\mu\text{s}$           | 49                 |
| $t_{UVLO\ OFF}$    | UVLO Turn-Off Delay <sup>(27)</sup>                                                                   |                                                                                                                                                                                                                          | 4.0  |      |      | $\mu\text{s}$           |                    |
| $t_{GP}$           | Time-to-Good Power <sup>(28)</sup>                                                                    | $V_{DD} = 0$ to 30 V in 10 $\mu\text{s}$ Ramp                                                                                                                                                                            | 2.0  |      |      | $\mu\text{s}$           | 28, 29, 49         |
| $ CM_H $           | Common Mode Transient Immunity at Output High                                                         | $T_A = 25^\circ\text{C}$ , $V_{CC} = 5\ \text{V}$ ,<br>$V_{DD} = 25\ \text{V}$ , $V_{SS} = \text{Ground}$ ,<br>$C_F = 15\ \text{pF}$ , $R_F = 4.7\ \text{k}\Omega$ ,<br>$V_{CM} = 1500\ \text{V}_{PEAK}$ <sup>(29)</sup> | 35   | 50   |      | $\text{kV}/\mu\text{s}$ | 51, 52             |
| $ CM_L $           | Common Mode Transient Immunity at Output Low                                                          | $T_A = 25^\circ\text{C}$ , $V_{CC} = 5\ \text{V}$ ,<br>$V_{DD} = 25\ \text{V}$ , $V_{SS} = \text{Ground}$ ,<br>$C_F = 15\ \text{pF}$ , $R_F = 4.7\ \text{k}\Omega$ ,<br>$V_{CM} = 1500\ \text{V}_{PEAK}$ <sup>(30)</sup> | 35   | 50   |      | $\text{kV}/\mu\text{s}$ | 50, 53             |

### Notes:

17. This load condition approximates the gate load of a 1200 V / 150 A IGBT.
18. Propagation delay  $t_{PHL}$  is measured from the 50% level on the falling edge of the input pulse to the 50% level of the falling edge of the  $V_O$  signal.
19. Propagation delay  $t_{PLH}$  is measured from the 50% level on the rising edge of the input pulse to the 50% level of the rising edge of the  $V_O$  signal.
20. PWD is defined as  $|t_{PHL} - t_{PLH}|$  for any given device.
21. The difference between  $t_{PHL}$  and  $t_{PLH}$  between any two parts under same operating conditions with equal loads.
22. The length of time the DESAT threshold must be exceeded before  $V_O$  begins to go LOW. This is supply voltage dependent.

23. The time from DESAT threshold is exceeded until the FAULT output goes LOW.
24. The length of time the DESAT threshold must be exceeded before  $V_O$  begins to go LOW and the FAULT output begins to go LOW.
25. The length of time from when RESET is initiated (via  $I_F$  turn-on) until FAULT output goes HIGH.
26. The UVLO turn-on delay,  $t_{UVLO\ ON}$ , is measured from the  $V_{UVLO+}$  threshold level of the rising edge of the output supply voltage ( $V_{DD}$ ) to the 5 V level of the rising edge of the  $V_O$  signal.
27. The UVLO turn-off delay,  $t_{UVLO\ OFF}$ , is measured from the  $V_{UVLO-}$  threshold level of the falling edge of the output supply voltage ( $V_{DD}$ ) to the 5 V level of the falling edge of the  $V_O$  signal.
28. The time to good power,  $t_{GP}$ , is measured from the  $V_{UVLO+}$  threshold level of the rising edge of the output supply voltage ( $V_{DD}$ ) to the 5 V level of the rising edge of the  $V_O$  signal.
29. Common-mode transient immunity at output HIGH state is the maximum tolerable negative  $dV_{CM}/dt$  on the trailing edge of the common-mode pulse,  $V_{CM}$ , to assure the output remains in HIGH state (i.e.,  $V_O > 15\text{ V}$  or  $V_{FAULT} > 2\text{ V}$ ).
30. Common-mode transient immunity at output LOW state is the maximum positive tolerable  $dV_{CM}/dt$  on the leading edge of the common-mode pulse,  $V_{CM}$ , to ensure the output remains in LOW state (i.e.,  $V_O < 1.0\text{ V}$  or  $V_{FAULT} < 0.8\text{ V}$ ).

### Timing Diagrams

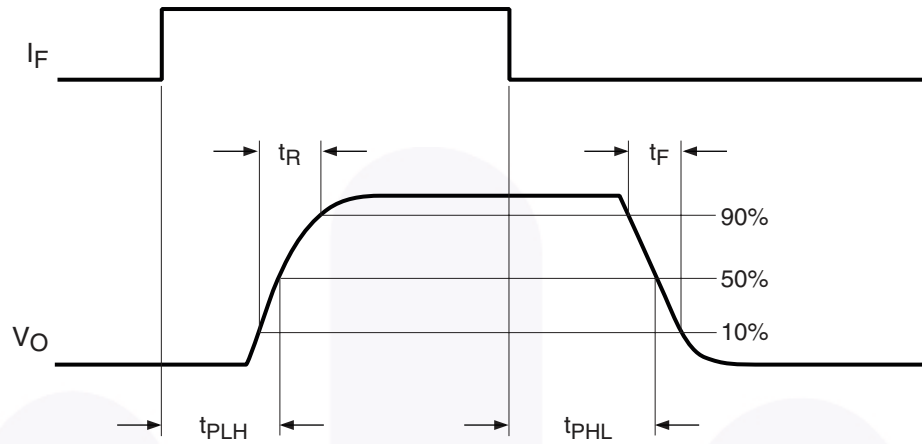


Figure 3.  $t_{PLH}$ ,  $t_{PHL}$ ,  $t_R$ , and  $t_F$  Timing Diagram

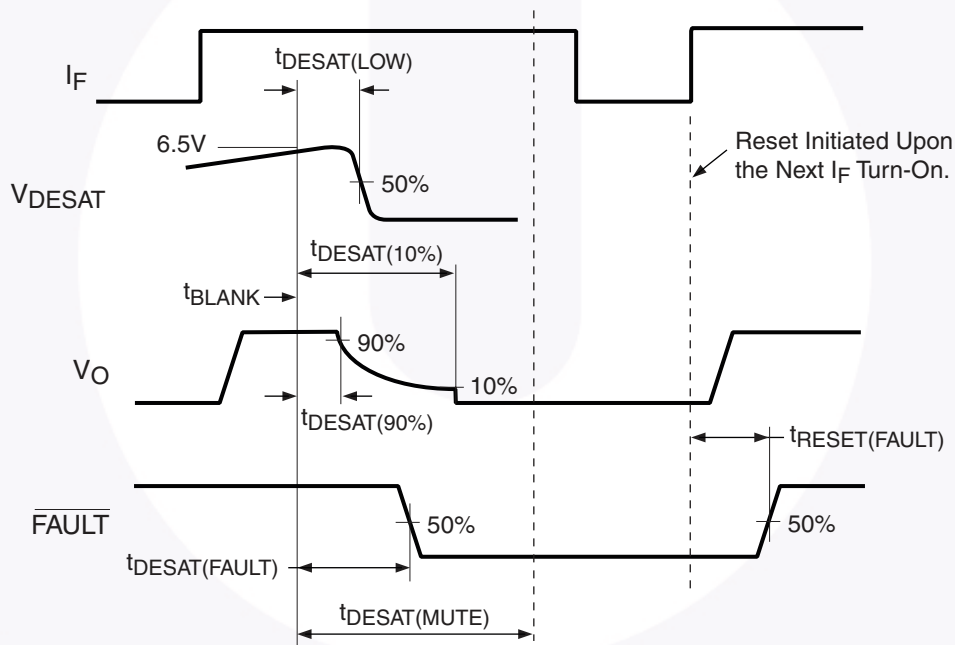
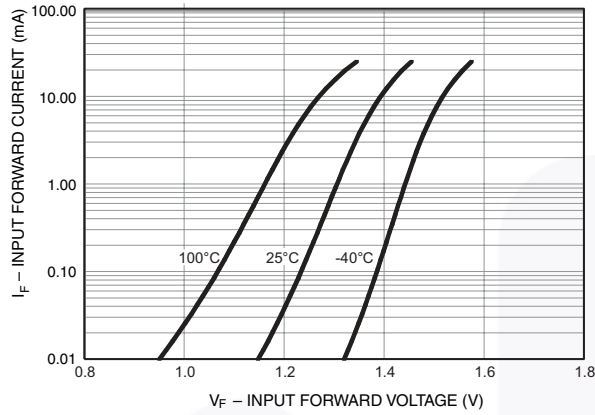
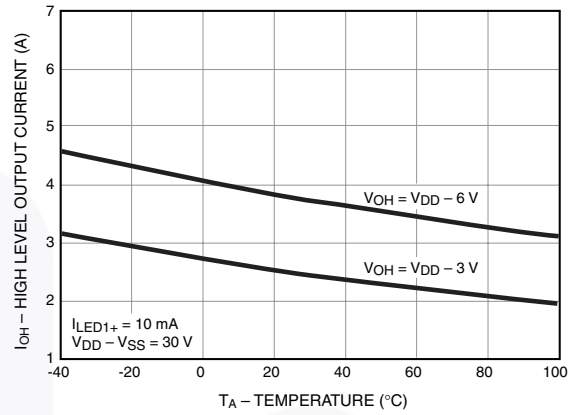


Figure 4. Definitions for DESAT,  $V_O$  and  $\overline{FAULT}$  Timing Waveforms

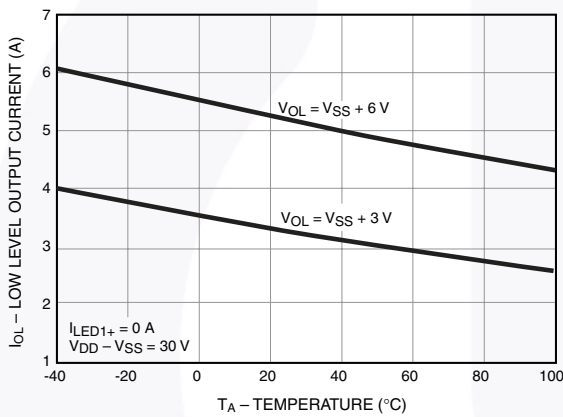
## Typical Performance Characteristics



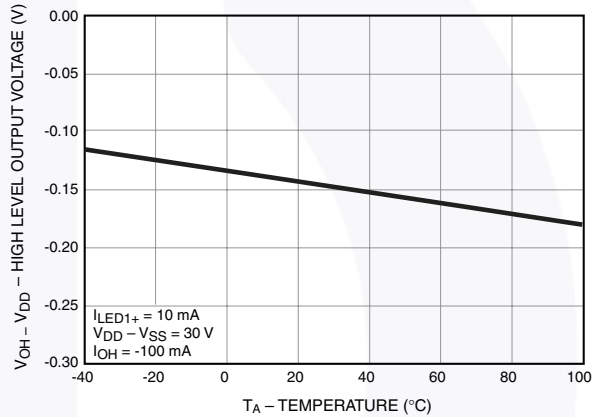
**Figure 5. Input Forward Current ( $I_F$ ) vs. Voltage ( $V_F$ )**



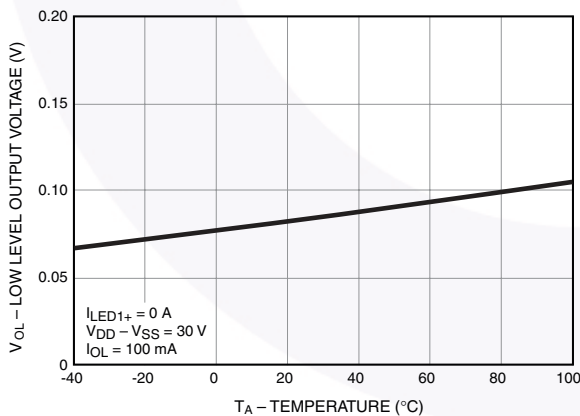
**Figure 6. High Level Output Current ( $I_{OH}$ ) vs. Temperature**



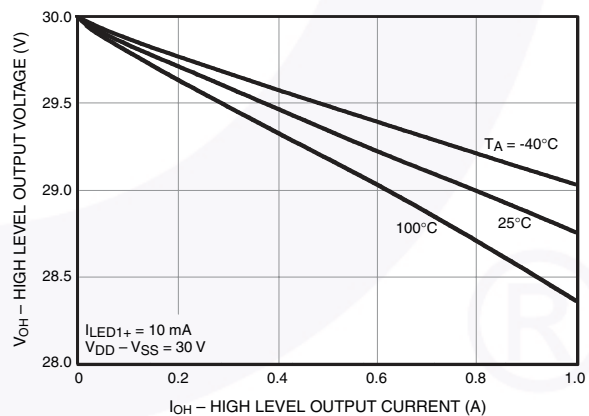
**Figure 7. Low Level Output Current ( $I_{OL}$ ) vs. Temperature**



**Figure 8. High Level Output Voltage ( $V_{OH} - V_{DD}$ ) vs. Temperature**

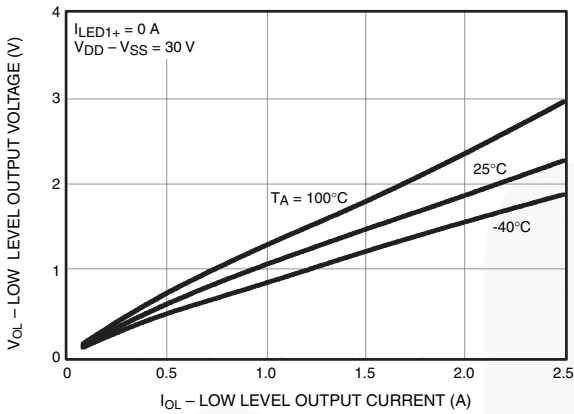


**Figure 9. Low Level Output Voltage ( $V_{OL}$ ) vs. Temperature**

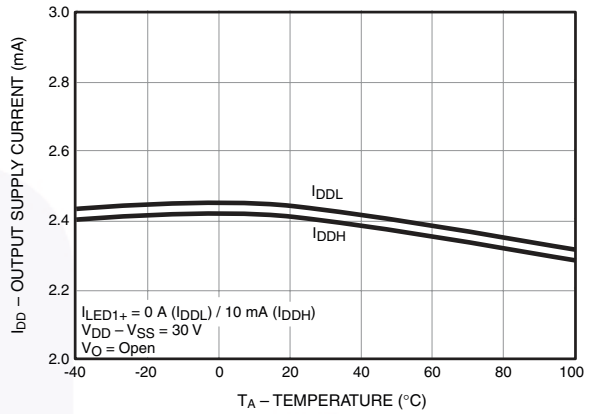


**Figure 10. High Level Output Voltage ( $V_{OH}$ ) vs. High Level Output Current ( $I_{OH}$ )**

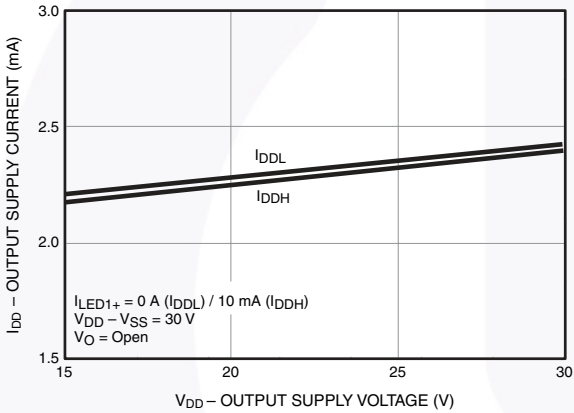
**Typical Performance Characteristics (Continued)**



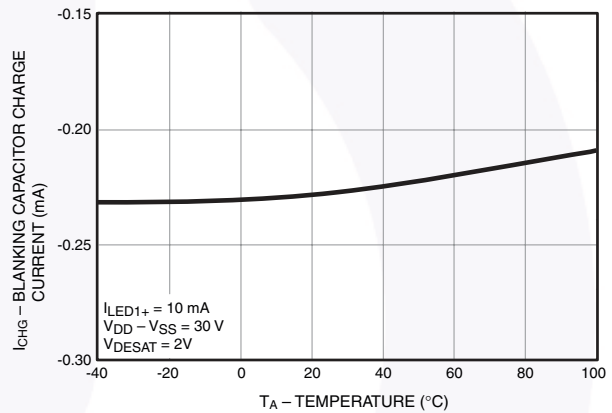
**Figure 11. Low Level Output Voltage ( $V_{OL}$ ) vs. Low Level Output Current ( $I_{OL}$ )**



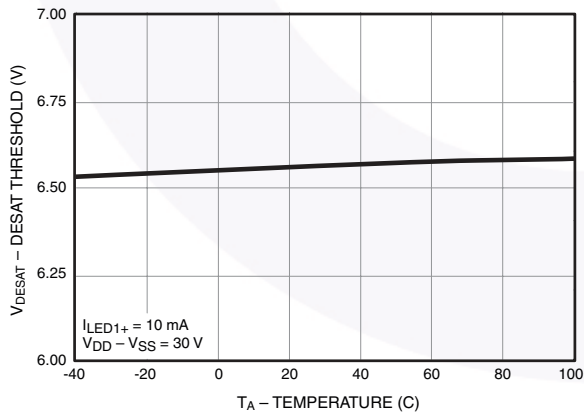
**Figure 12. Output Supply Current ( $I_{DD}$ ) vs. Temperature**



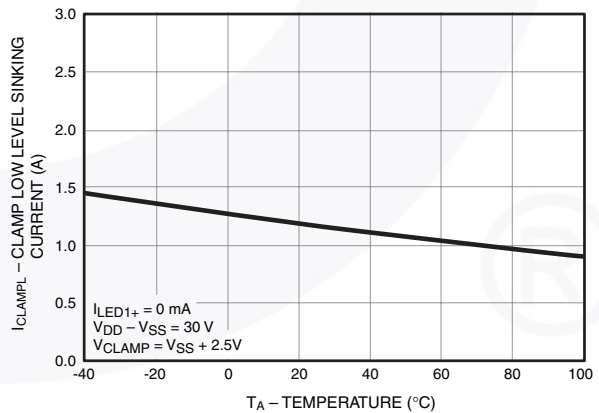
**Figure 13. Output Supply Current ( $I_{DD}$ ) vs. Voltage ( $V_{DD}$ )**



**Figure 14. Blanking Capacitor Charge Current ( $I_{CHG}$ ) vs. Temperature**

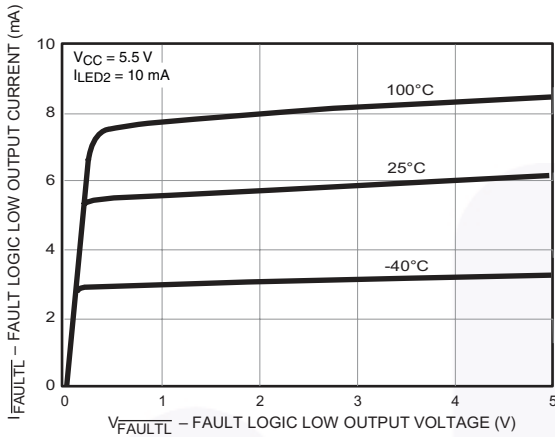


**Figure 15. DESAT Threshold ( $V_{DESAT}$ ) vs. Temperature**

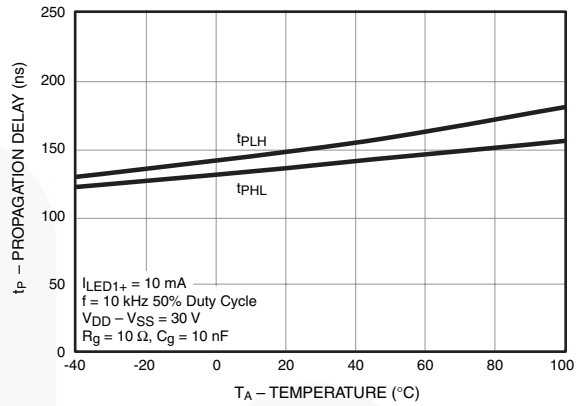


**Figure 16. Clamp Low Level Sinking Current ( $I_{CLAMPL}$ ) vs. Temperature**

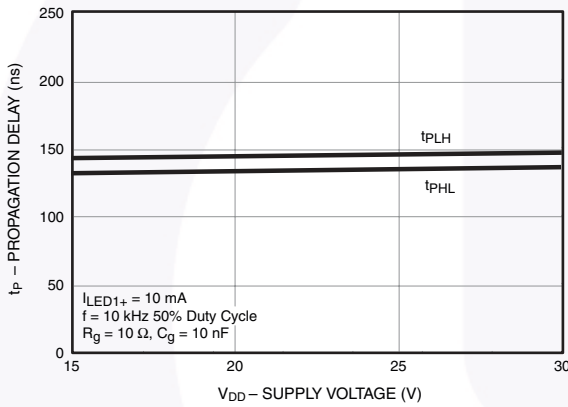
### Typical Performance Characteristics (Continued)



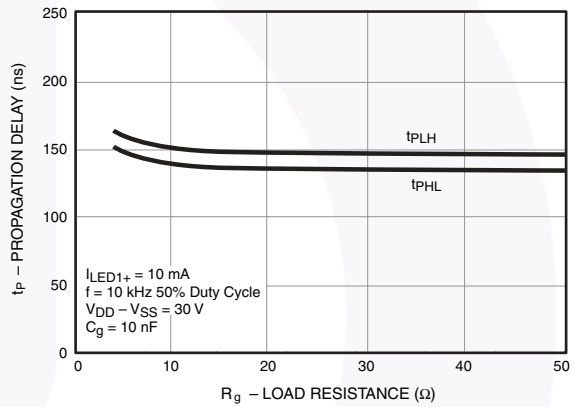
**Figure 17. FAULT Logic Low Output Current ( $I_{\text{FAULTL}}$ ) vs. Voltage ( $V_{\text{FAULTL}}$ )**



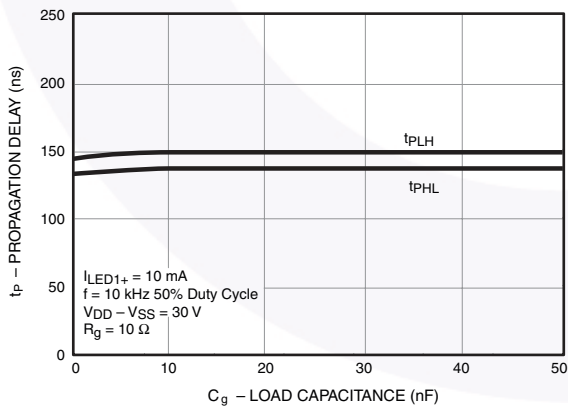
**Figure 18. Propagation Delay ( $t_p$ ) vs. Temperature**



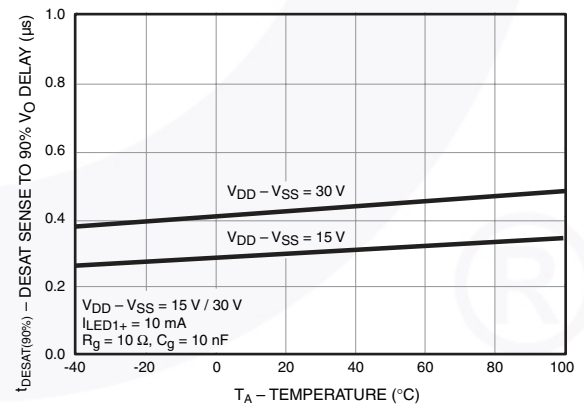
**Figure 19. Propagation Delay ( $t_p$ ) vs. Supply Voltage ( $V_{\text{DD}}$ )**



**Figure 20. Propagation Delay ( $t_p$ ) vs. Load Resistance ( $R_g$ )**

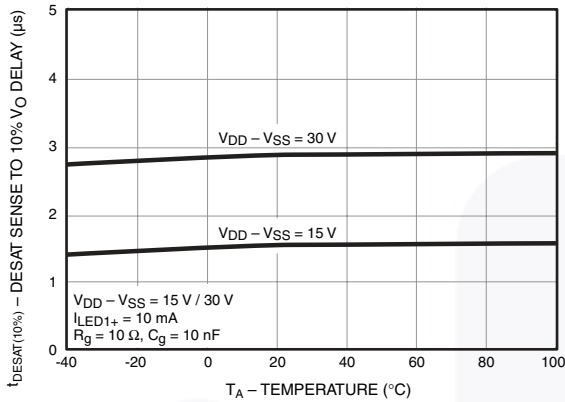


**Figure 21. Propagation Delay ( $t_p$ ) vs. Load Capacitance ( $C_g$ )**

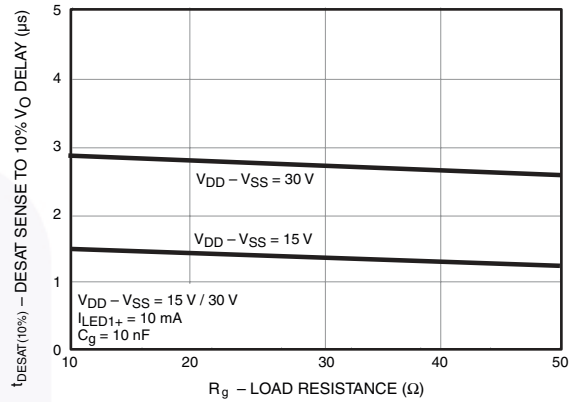


**Figure 22. DESAT Sense to 90%  $V_O$  Delay ( $t_{\text{DESAT}(90\%)}$ ) vs. Temperature**

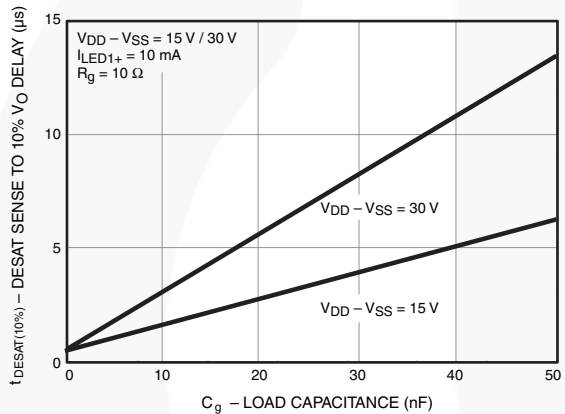
**Typical Performance Characteristics (Continued)**



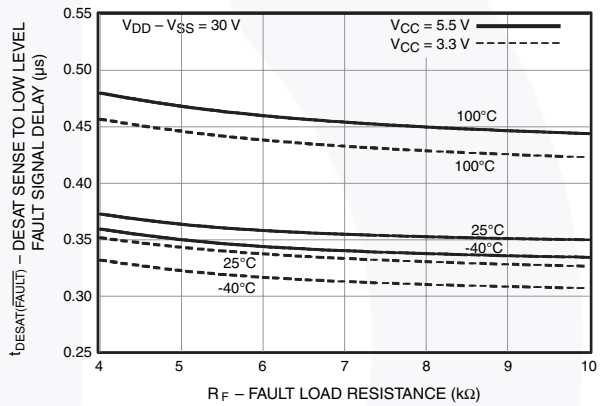
**Figure 23. DESAT Sense to 10%  $V_O$  Delay ( $t_{DESAT(10\%)}$ ) vs. Temperature**



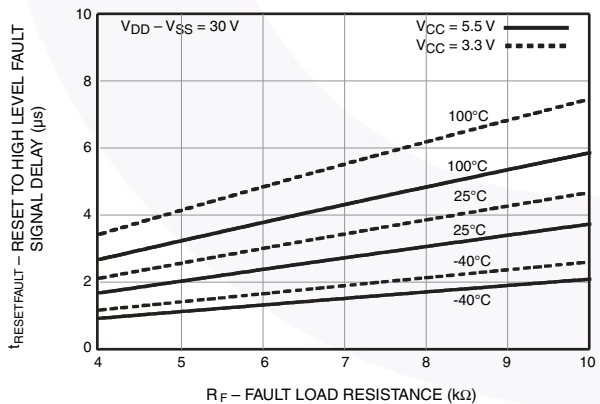
**Figure 24. DESAT Sense to 10%  $V_O$  Delay ( $t_{DESAT(10\%)}$ ) vs. Load Resistance ( $R_g$ )**



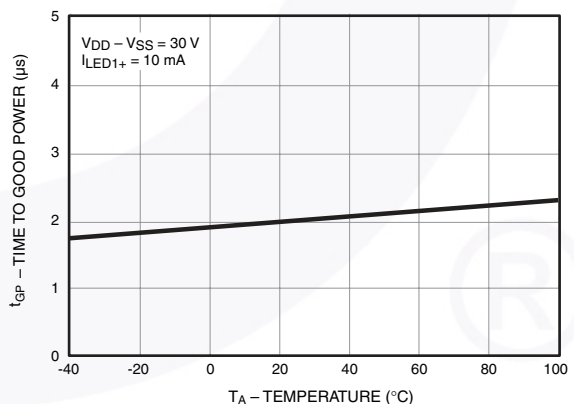
**Figure 25. DESAT Sense to 10%  $V_O$  Delay ( $t_{DESAT(10\%)}$ ) vs. Load Capacitance ( $C_g$ )**



**Figure 26. DESAT Sense to Low Level Fault Signal Delay ( $t_{DESAT(FAULT)}$ ) vs. Fault Load Resistance ( $R_F$ )**



**Figure 27. RESET to High Level Fault Signal Delay ( $t_{RESET(FAULT)}$ ) vs. Fault Load Resistance ( $R_F$ )**



**Figure 28. Time-to-Good Power ( $t_{GP}$ ) vs. Temperature**



### Typical Performance Characteristics (Continued)

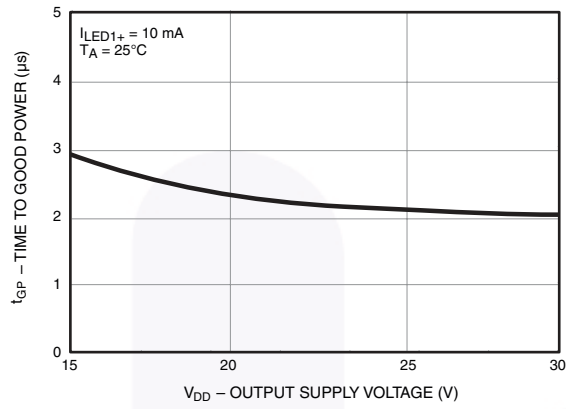


Figure 29. Time-to-Good Power ( $t_{GP}$ ) vs. Output Supply Voltage ( $V_{DD}$ )

## Test Circuits

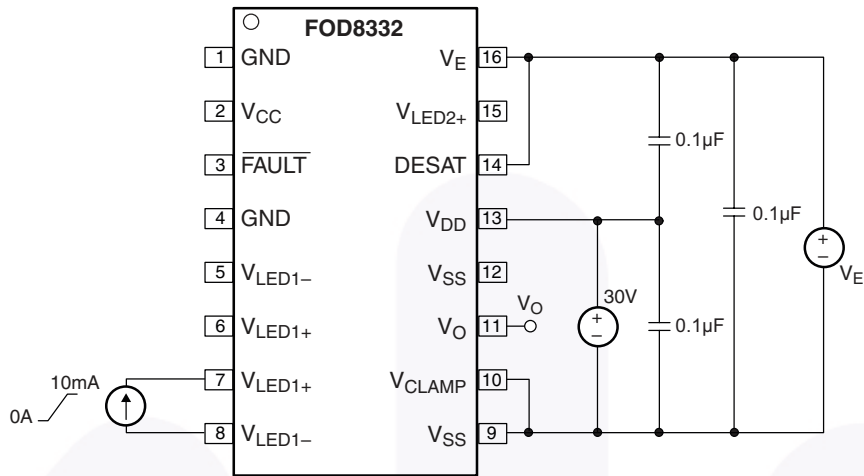


Figure 30. Threshold Input Current Low-to-High ( $I_{FLH}$ ) Test Circuit

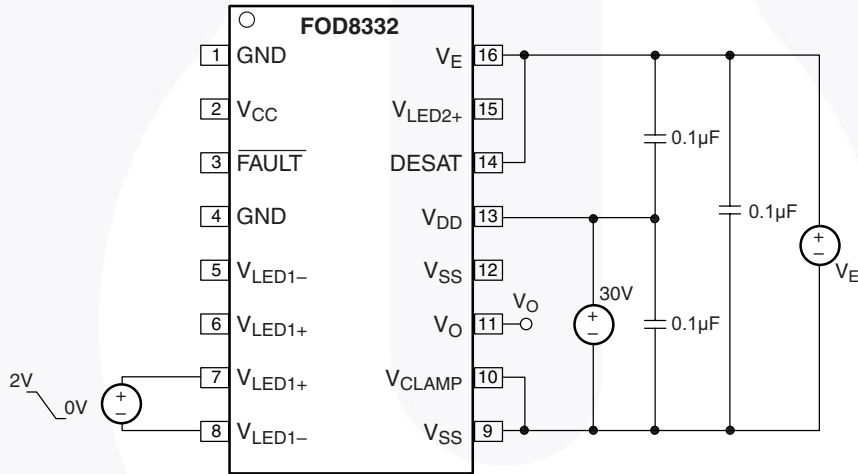


Figure 31. Threshold Input Voltage High-to-Low ( $V_{FHL}$ ) Test Circuit

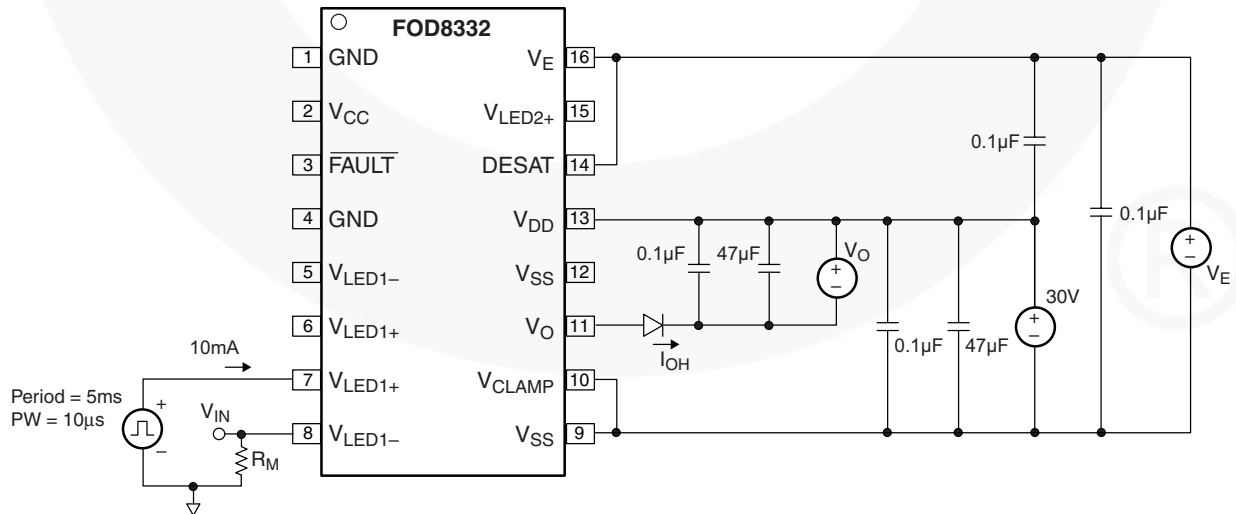
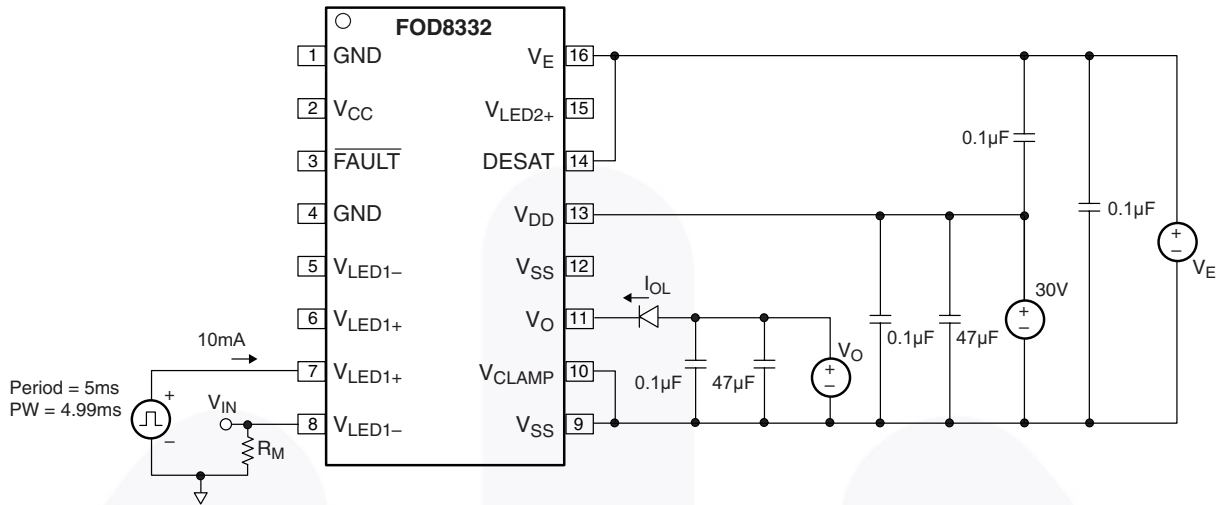
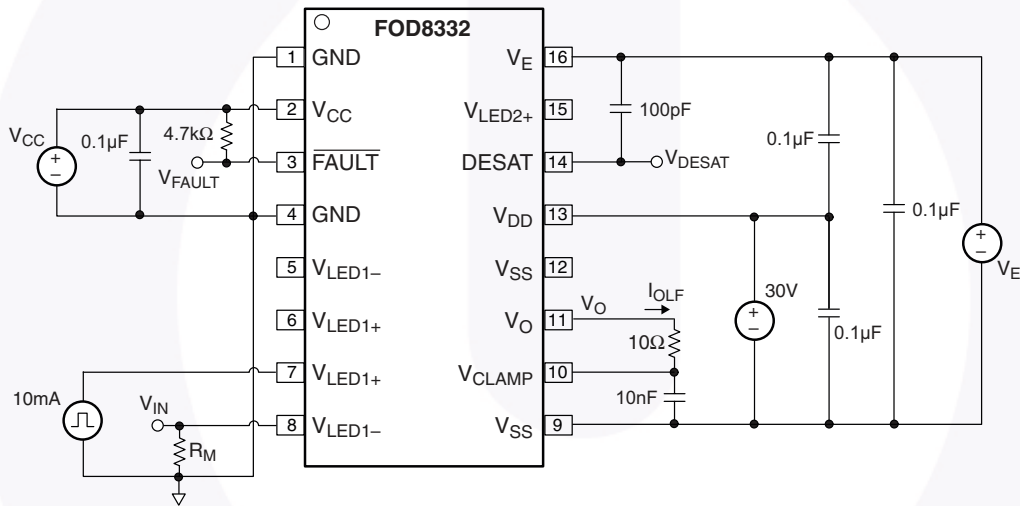


Figure 32. High Level Output Current ( $I_{OH}$ ) Test Circuit

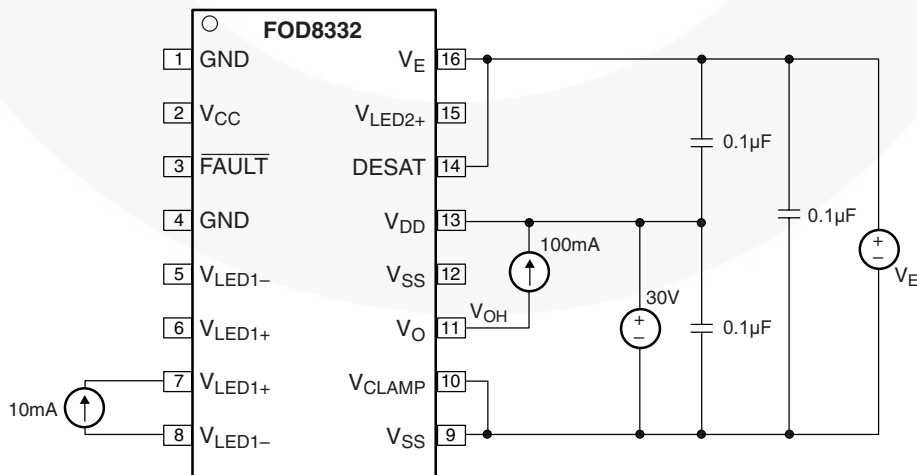
**Test Circuits** (Continued)



**Figure 33. Low Level Output Current ( $I_{OL}$ ) Test Circuit**

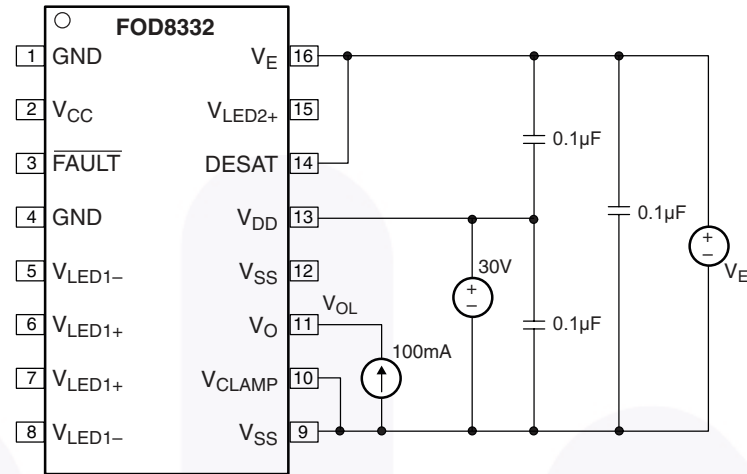


**Figure 34. Low Level Output Current During Fault Condition ( $I_{OLF}$ ) Test Circuit**

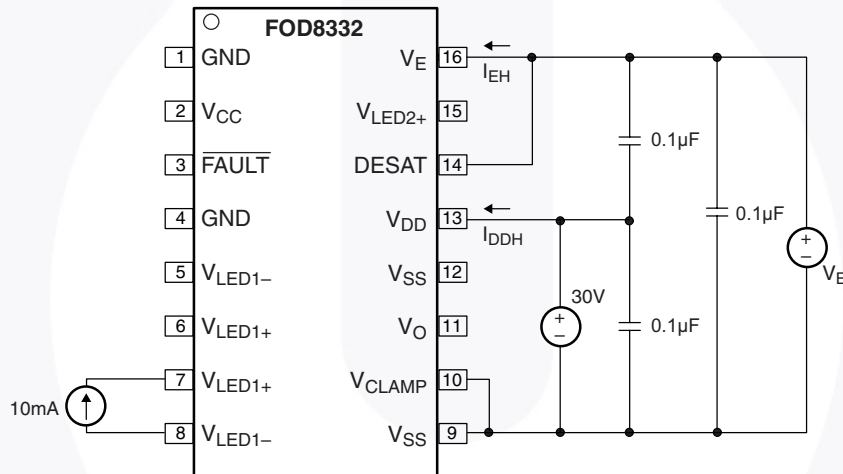


**Figure 35. High Level Output Voltage ( $V_{OH}$ ) Test Circuit**

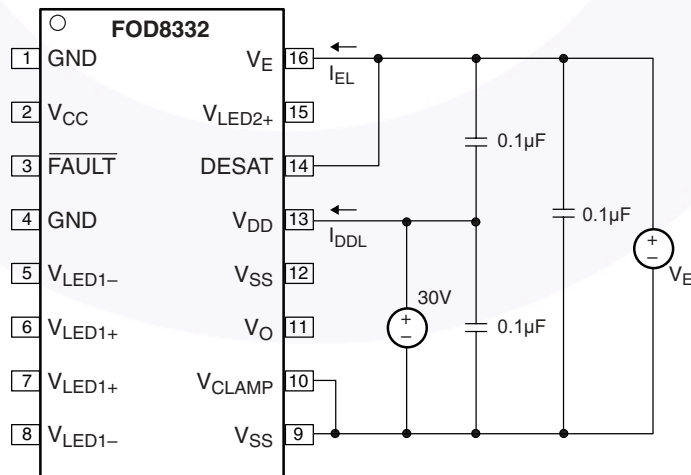
**Test Circuits** (Continued)



**Figure 36. Low Level Output Voltage ( $V_{OL}$ ) Test Circuit**

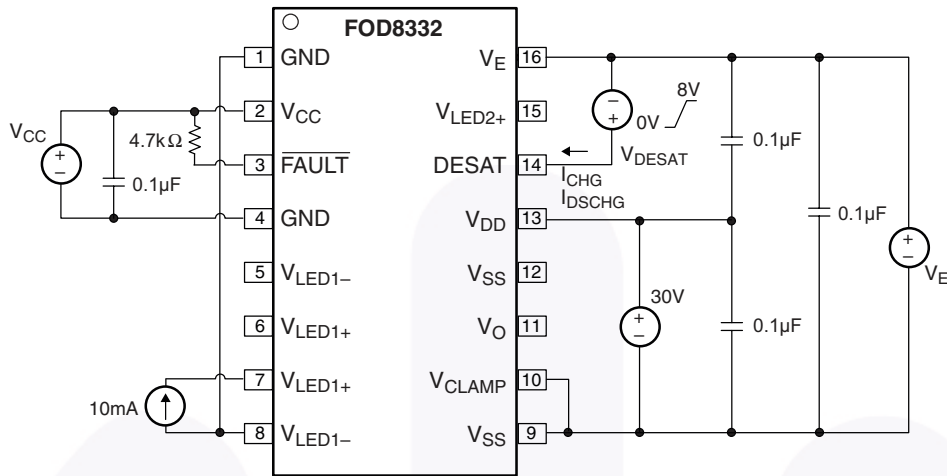


**Figure 37. High Level Supply Current ( $I_{DDH}$ ),  $V_E$  High Level Supply Current ( $I_{EH}$ ) Test Circuit**

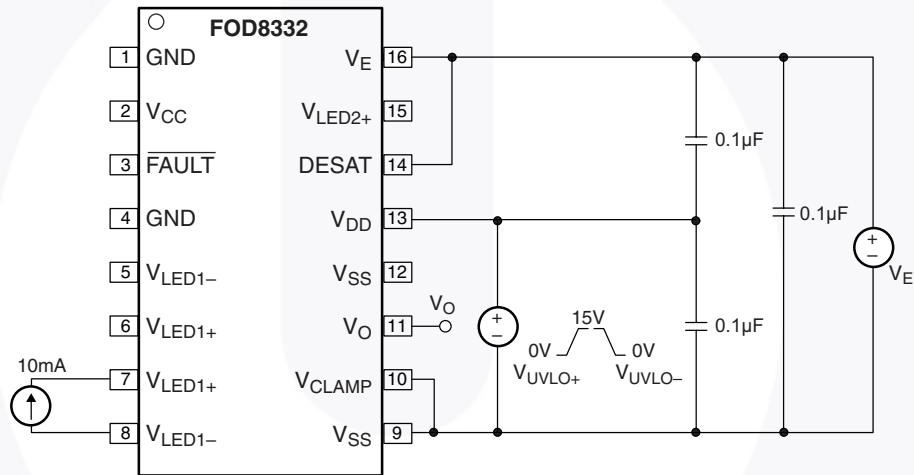


**Figure 38. Low Level Supply Current ( $I_{DDL}$ ),  $V_E$  Low Level Supply Current ( $I_{EL}$ ) Test Circuit**

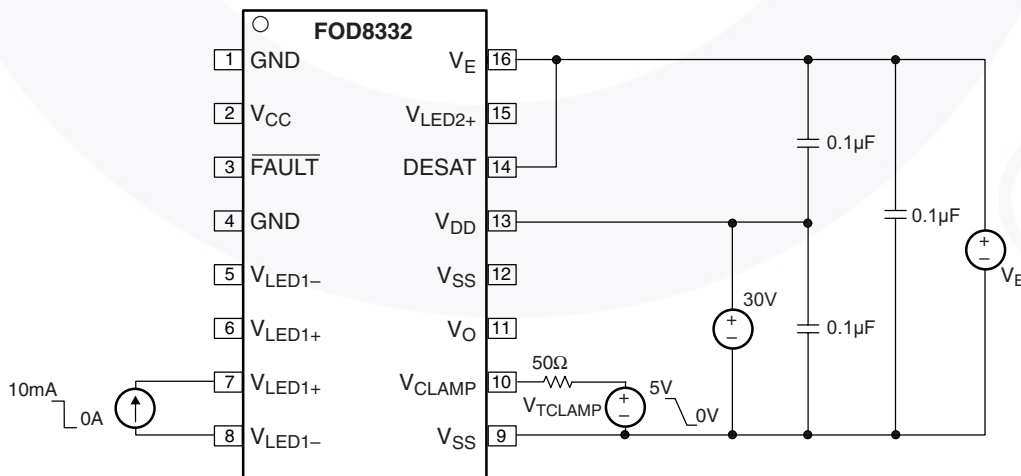
**Test Circuits** (Continued)



**Figure 39. DESAT Threshold ( $V_{DESAT}$ ), Blanking Capacitor Charge Current ( $I_{CHG}$ ), Blanking Capacitor Discharge Current ( $I_{DSCHG}$ ) Test Circuit**

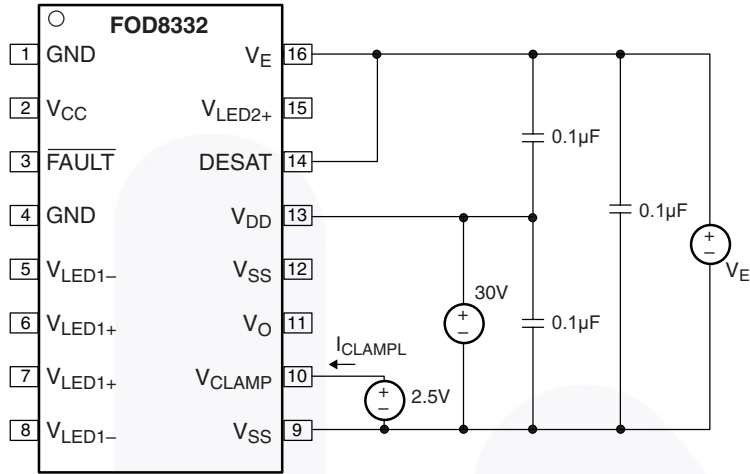


**Figure 40. Under-Voltage Lockout Threshold ( $V_{UVLO+}$  /  $V_{UVLO-}$ ), Under-Voltage Lockout Threshold Hysteresis ( $UVLO_{HYS}$ ) Test Circuit**

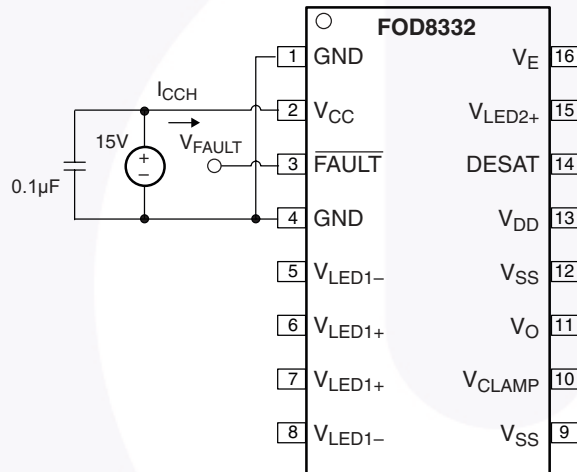


**Figure 41. Clamping Threshold Voltage ( $V_{CLAMP\_THRES}$ ) Test Circuit**

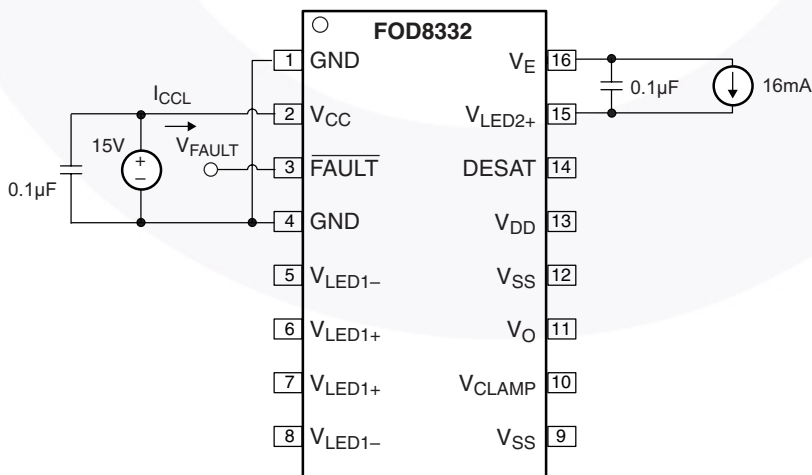
**Test Circuits** (Continued)



**Figure 42. Clamp Low Level Sinking Current ( $I_{CLAMPL}$ ) Test Circuit**

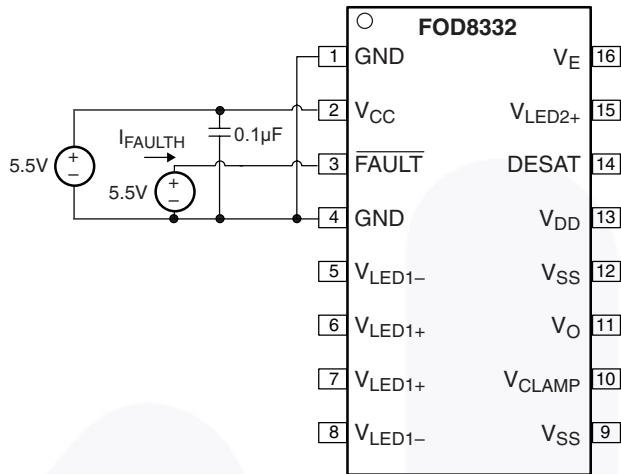


**Figure 43. FAULT High Level Supply Current ( $I_{CCH}$ ) Test Circuit**

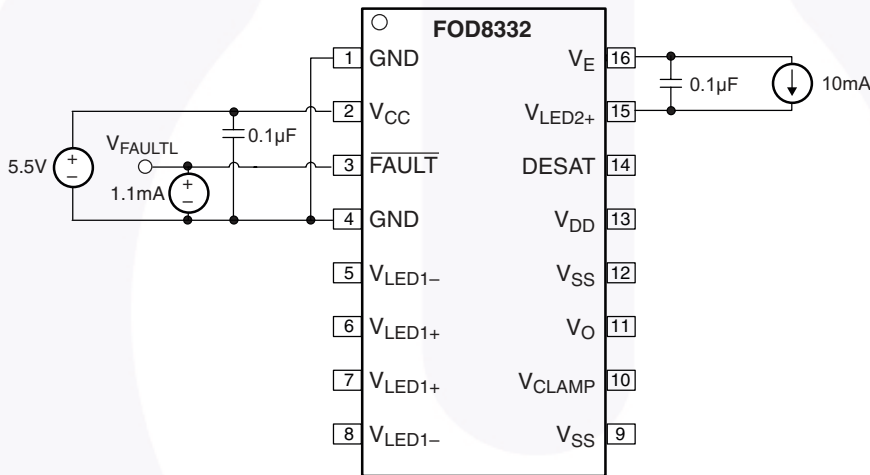


**Figure 44. FAULT Low Level Supply Current ( $I_{CCL}$ ) Test Circuit**

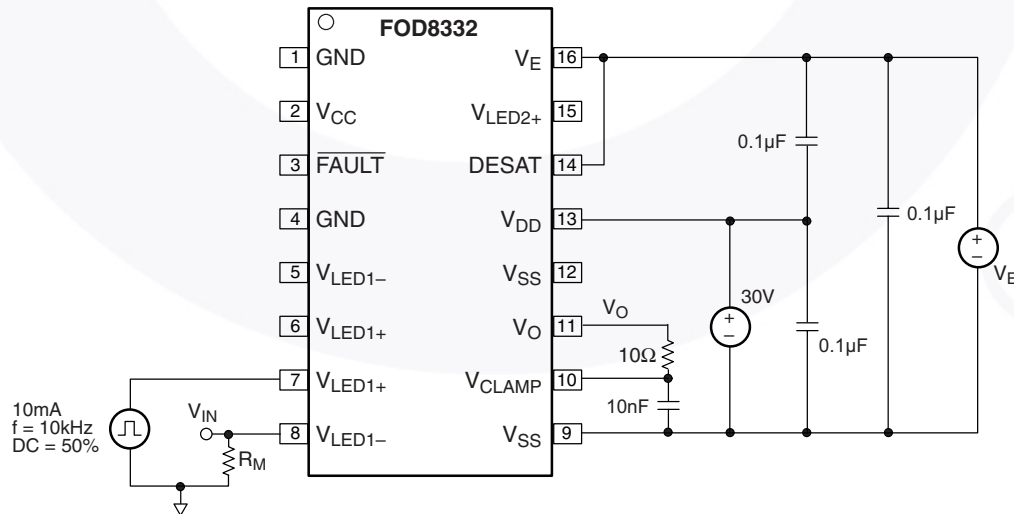
**Test Circuits** (Continued)



**Figure 45. FAULT High Level Output Current ( $I_{\text{FAULTH}}$ ) Test Circuit**

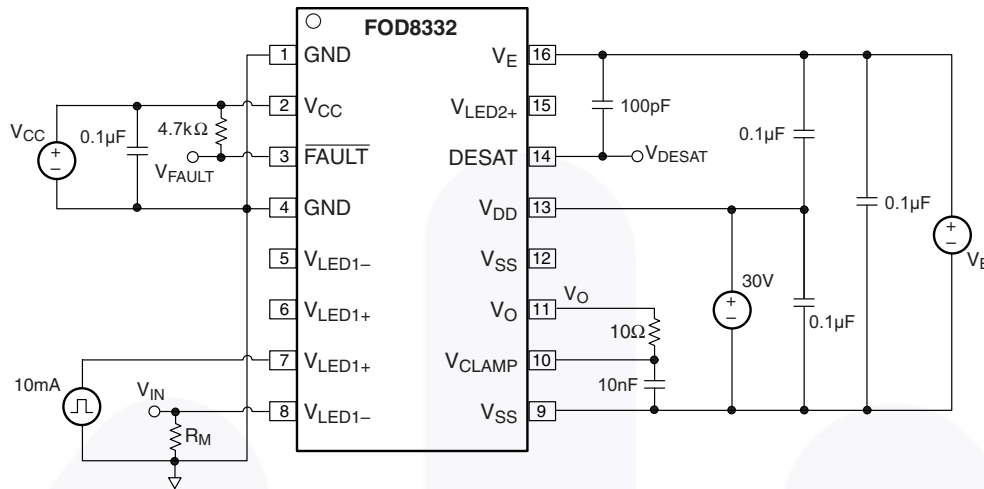


**Figure 46. FAULT Low Level Output Voltage ( $V_{\text{FAULTL}}$ ) Test Circuit**

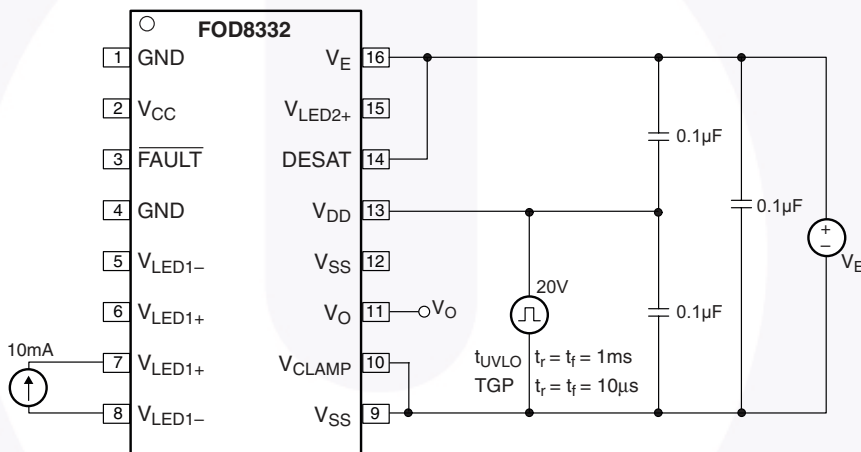


**Figure 47. Propagation Delay ( $t_{\text{PLH}}$ ,  $t_{\text{PHL}}$ ), Rise Time ( $t_{\text{R}}$ ), Fall Time ( $t_{\text{F}}$ ), Pulse Width Distortion (PWD) Test Circuit**

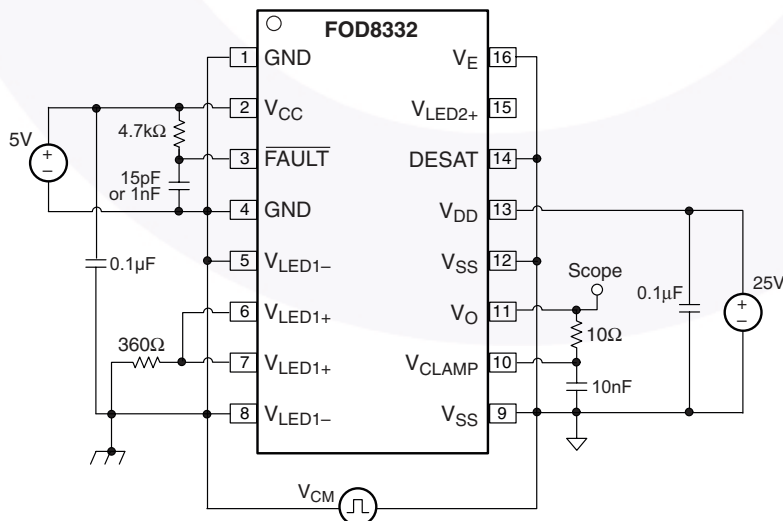
**Test Circuits** (Continued)



**Figure 48. DESAT Sense Delay ( $t_{DESAT(90\%)}$ ),  $t_{DESAT(10\%)}$ ,  $t_{DESAT(LOW)}$ ), DESAT Sense to Low Level FAULT Signal Delay ( $t_{DESAT(FAULT)}$ ), Reset to High Level FAULT Signal Delay ( $t_{RESET(FAULT)}$ ), DESAT Input Mute ( $t_{DESAT(MUTE)}$ ) Test Circuit**



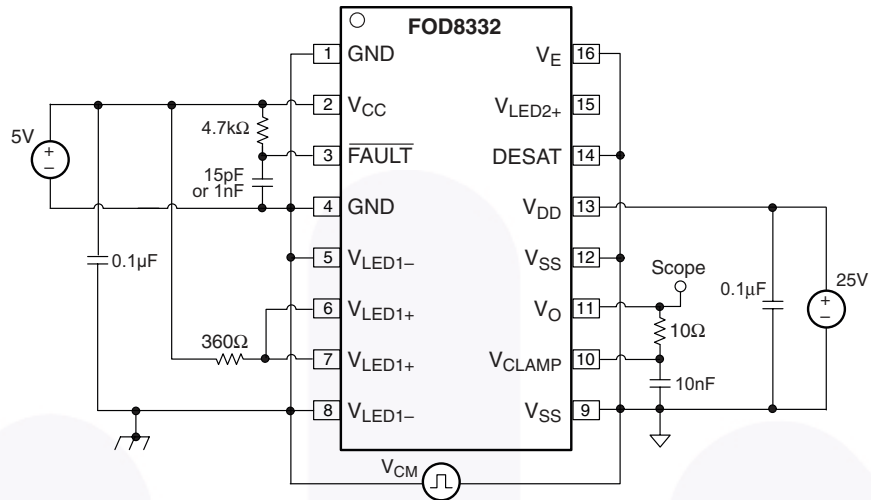
**Figure 49. Under-Voltage Lockout Delay ( $t_{UVLO}$ ), Time-to-Good-Power ( $t_{GTP}$ ) Test Circuit**



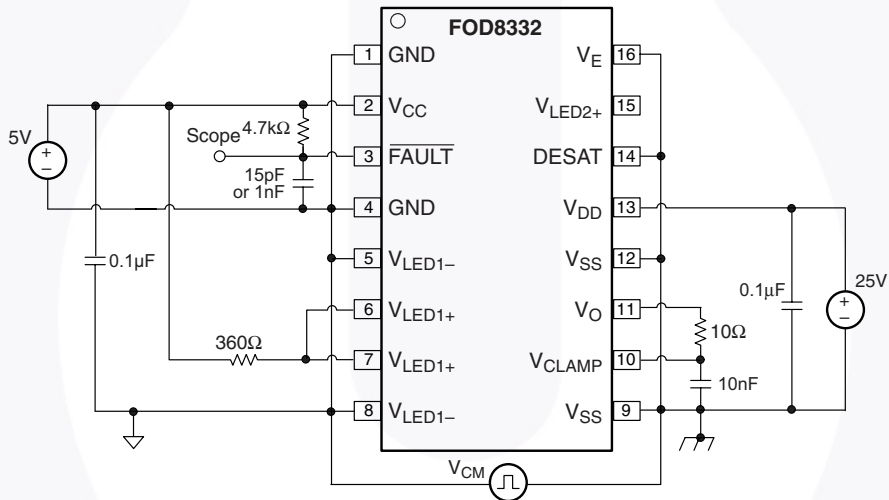
**Figure 50. Common-Mode Low (CML) LED1-Off Test Circuit**



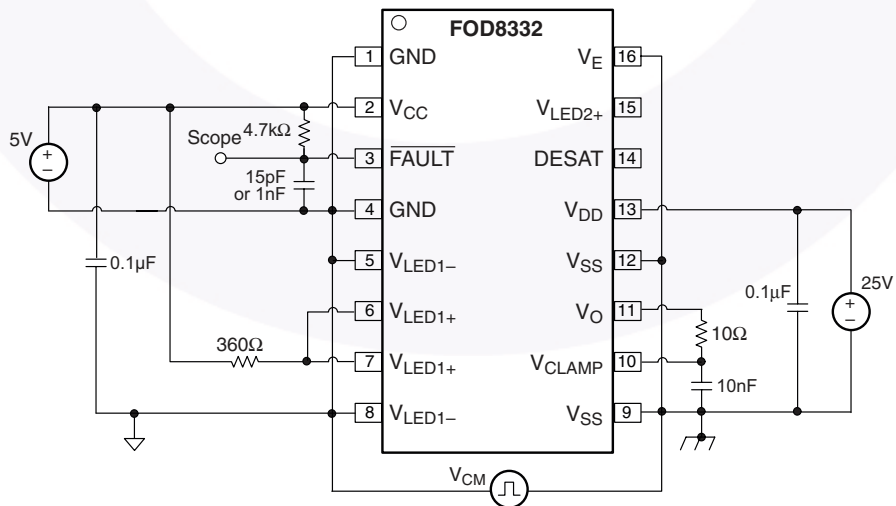
**Test Circuits** (Continued)



**Figure 51. Common-Mode High (CMH) LED1-On Test Circuit**



**Figure 52. Common-Mode High (CMH) LED2-Off Test Circuit**



**Figure 53. Common-Mode High (CML) LED2-On Test Circuit**

## Application Information

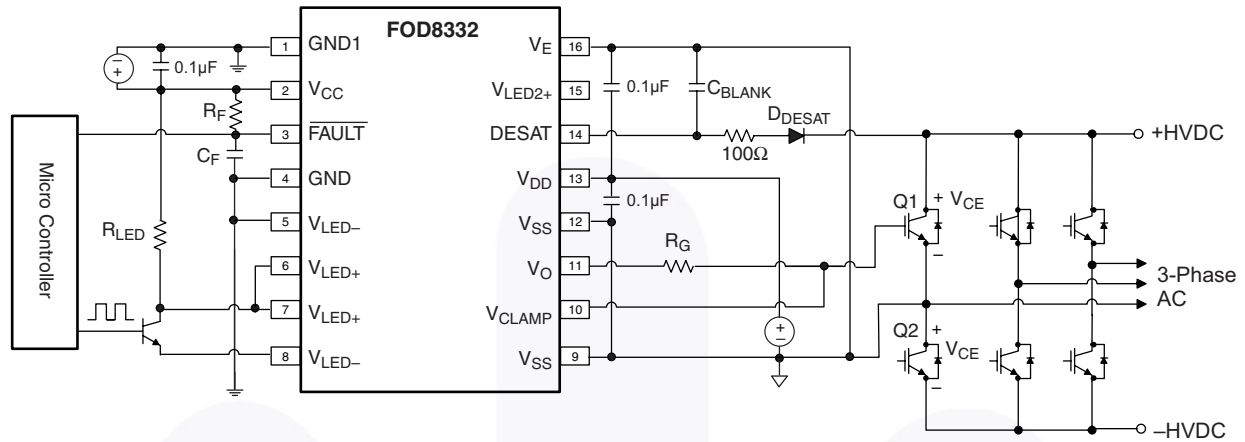


Figure 54. Recommended Application Circuit

## Functional Description

The functional behavioral of FOD8332 is illustrated by the detailed internal schematic shown in Figure 55.

Figure 55 and the timing diagrams explain the interaction and sequence of internal and external signals.

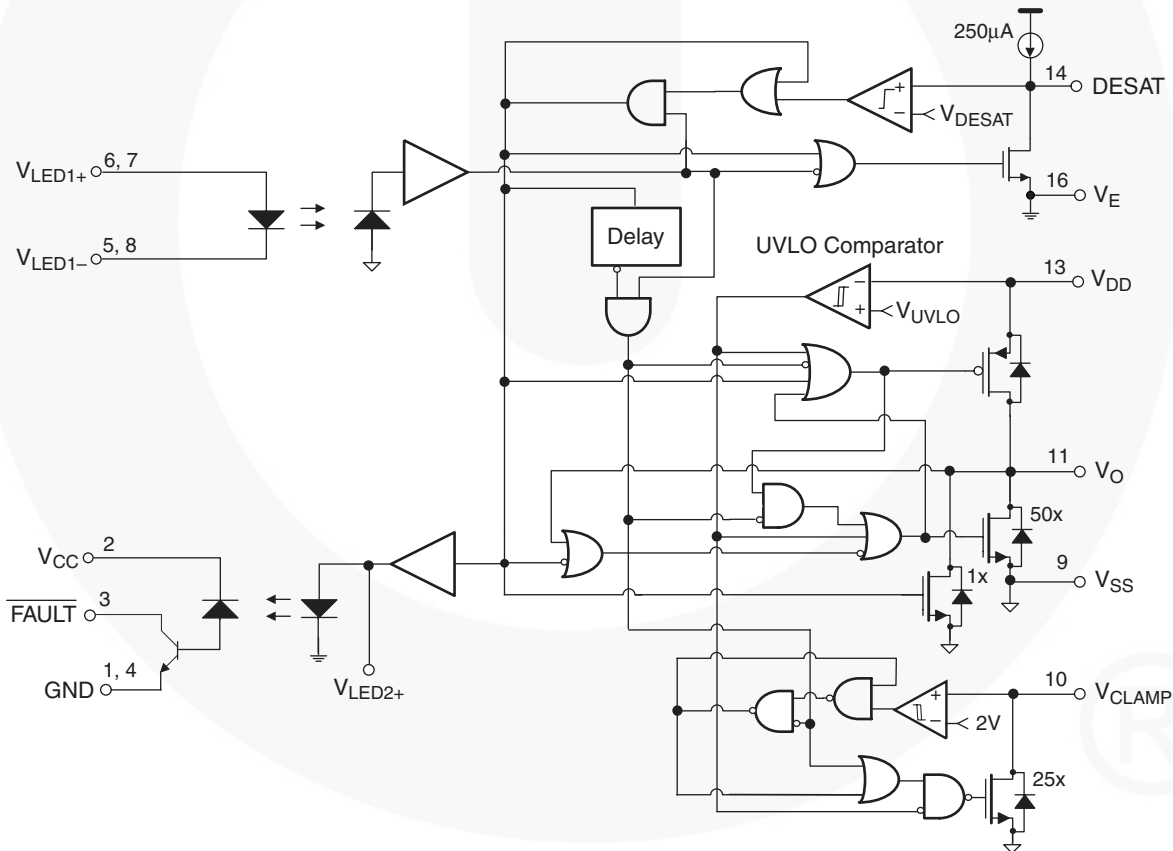
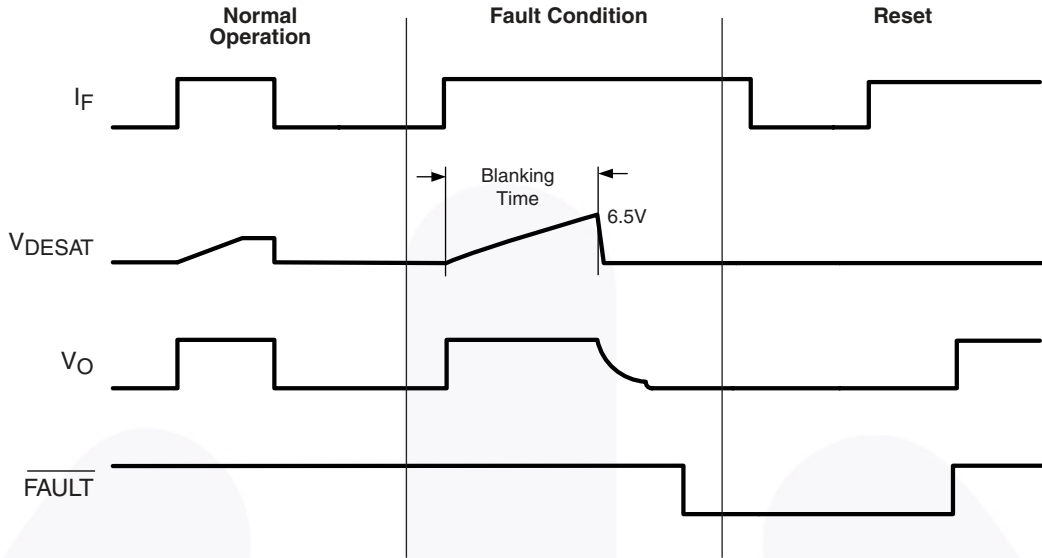


Figure 55. Detailed Internal Behavioral Schematic



**Figure 56. Operating Relationship Among Desaturation Voltage (DESAT), Fault Output (FAULT), and Reset Conditions**

### 1. LED Input and Operation Explanation

FOD8332 is an advanced IGBT gate-drive optocoupler capable of driving most 1200 V / 150 A IGBTs and power MOSFETs in motor control and inverter applications. The following section describes driving IGBT, but is also applicable to driving MOSFET. Adjust the  $V_{DD}$  supply based on the gate threshold voltages. Critical protection features and controls are incorporated to simplify the design and improve reliability. The device includes an IGBT desaturation detection protection and a FAULT status output.

This highly integrated device consists of two high-performance AlGaAs LEDs and two integrated circuits. LED1 directly controls the isolated gate driver IC output, while the returned optical signal path is transmitted by LED2, which reports the fault status through the open-collector fault-sense IC output.

The control LED input and the fault-sense IC output can be connected to a standard 3.3 V / 5 V DSP or microcontroller. The gate driver output can be connected to the gate of the power devices on the high-voltage side. A typical recommended application is shown in Figure 54. A typical shunt LED drive can be used to improve noise immunity. The LED is connected in parallel with the bipolar transistor switch, creating a current shunt drive. Common-mode transients from the load coupling via the package capacitance can be coupled into a low-impedance path, either the conducting LED or the on resistance of the conducting bipolar transistor, increasing its noise immunity.

During normal operation, when no fault is detected, LED1 controls the gate driver output.  $V_O$  is set to HIGH

when the current flowing from the anode to the cathode (LED1) is greater than  $I_{FLH}$  and the forward voltage  $V_F$  is greater than  $V_F(MIN)$ . The timing relationship between the LED input and gate driver output is illustrated in Figure 3. When a fault is detected, the gate driver output IC immediately enters “soft” turn-off mode, where the output voltage changes slowly from HIGH to LOW state. This also disables the gate control input on the gate driver IC side for a minimum mute time of 10  $\mu s$ .

The FAULT output, which is open-collector configuration, is latched to LOW state to report a fault status to the microcontroller. It is only reset or pulled back to HIGH when LED1 is pulled from LOW to HIGH again.

The active Miller clamp function avoids the need of negative gate driving in most applications and allows the use of a simple bootstrap supply for the high-side driver.

### 2. Gate Driver Output

A pair of PMOS and NMOS make up the output driver stage, which facilitates close to rail-to-rail output swing. This feature allows tight control of gate voltage during on-state and short-circuit conditions.

The output driver can typically sink 2.5 A and source 2.5 A at room temperature. Due to the low  $R_{DS(ON)}$  of the MOSFETs, the power dissipation is lower than bipolar-type driver output stages. The absolute maximum rating of the output peak current,  $I_{O(PEAK)}$ , is 3 A. Careful selection of the gate resistor,  $R_G$ , is required to avoid violation of this rating. For charging and discharging, the  $R_G$  value is approximated by:

$$R_G = \frac{V_{CC} - V_{EE} - V_{OL}}{I_{OL(PEAK)}} \quad (1)$$

As shown in Figure 55, the gate driver output is influenced by signals from the photodetector circuitry, the UVLO comparator, and the DESAT signals. Under no-fault condition, normal operation resumes while the supply voltage is above the UVLO threshold and the output of the photodetector drives the MOSFETs of the output stage. The logic circuitry of the output stage ensures that the push-pull devices are never turned ON simultaneously. When the output of the photodetector is HIGH, output  $V_O$  is pulled to HIGH state by turning on the PMOS. When the output of the photodetector is LOW,  $V_O$  is pulled to LOW state by turning on the 50XNMOS.

When  $V_{DD}$  supply goes below  $V_{UVLO}$ , which is the designated ULVO threshold at the comparator,  $V_O$  is pulled to LOW state regardless of photodetector output.

When  $V_O$  is HIGH and desaturation is detected,  $V_O$  turns off slowly as it is pulled LOW by the 1XNMOS device. The input to the fault-sense circuitry is latched to HIGH state and turns on the LED2. The fault-sense signal remains in HIGH state until LED1 is switched from LOW to HIGH. When  $V_O$  goes below 2 V, the 50XNMOS device turns on, clamping the IGBT gate firmly to  $V_{SS}$ .

### 3. Desaturation Protection, FAULT Output and FAULT RESET

Desaturation detection protects the IGBT in short circuit by monitoring the collector-emitter voltage of the IGBT when it's turned on. When the DESAT pin voltage goes above the threshold voltage, a short-circuit condition is detected and the driver output stage executes a "soft" IGBT turn-off and is eventually driven LOW. This sequence is illustrated in Figure 56. The FAULT open-collector output is triggered active LOW to report a desaturation error. The gate driver output is muted for minimum of 10  $\mu$ s. All input LED signals are ignored during the mute period to allow the driver to completely soft shutdown the IGBT. The fault mechanism is reset by the next LED turn-on after the  $t_{RESET(FAULT)}$  (see Figure 56). During OFF state of the IGBT, or if  $V_O$  is LOW, the fault sense circuitry is disabled to prevent false fault signals.

The DESAT comparator should be disabled for a short time period (blanking time) before the IGBT turns on to allow the collector voltage to fall below the DESAT threshold.

This blanking period protects against false triggering of the DESAT while the IGBT is turning on. The blanking time is controlled by the internal DESAT charge current, the DESAT voltage threshold, and the external DESAT capacitor (capacitor between DESAT and  $V_E$  pin). The

nominal blanking time can be calculated using external capacitance ( $C_{BLANK}$ ), FAULT threshold voltage ( $V_{DESAT}$ ), and DESAT charge current ( $I_{CHG}$ ):

$$t_{BLANK} = C_{BLANK} \times V_{DESAT} / I_{CHG} \quad (2)$$

With a recommended 100 pF DESAT capacitor, the nominal blanking time is:

$$100 \text{ pF} \times 6.5 \text{ V} / 250 \text{ } \mu\text{A} = 2.6 \text{ } \mu\text{s}$$

### 4. Soft Turn-Off

The soft turn-off feature ensures the safe shutdown of the IGBT under fault condition. The gate-driver voltage  $V_O$  turns off the IGBT in a controlled slow manner. This reduces the voltage spike on the collector of the IGBT. Without this, the IGBT would see a heavy spike on the collector, resulting in a permanent damage to the device when it's turned off immediately. The  $V_O$  is pulled to LOW slowly in 4  $\mu$ s.

### 5. Under-Voltage Lockout (UVLO)

Under-Voltage detection prevents the application of insufficient gate voltage to the IGBT. This could be dangerous, as it would drive the IGBT out of saturation and into the linear operation where losses are very high and the IGBT quickly overheats. This feature ensures proper operation of the IGBTs. The output voltage,  $V_O$ , remains LOW irregardless of the inputs, as long as the supply voltage,  $V_{DD} - V_E$ , is less than  $V_{UVLO+}$  during power up. When the supply voltage falls below  $V_{UVLO-}$ ,  $V_O$  goes LOW, as illustrated in Figure 57.

### 6. Active Miller Clamp Function

An active Miller clamp feature allows the sinking of the Miller current to ground during a high-dV/dt situation. Instead of driving the IGBT gate to a negative supply voltage to increase the safety margin, the device has a dedicated  $V_{CLAMP}$  pin to control the Miller current. During turn-off, the gate voltage of the IGBT is monitored and the  $V_{CLAMP}$  output is activated when the gate voltage goes below 2 V (relative to  $V_{SS}$ ).

The Miller clamp NMOS transistor is then turned on and provides a low resistive path for the Miller current, which helps prevent a self-turn-on due to the parasitic Miller capacitor in power switches. The clamp voltage is  $V_{SS} + 2.5 \text{ V}$ , typical for a Miller current up to 1100 mA.

In this way, the  $V_{CLAMP}$  function does not affect the turn-off characteristic. It helps to clamp the gate to the low level throughout the turn-off time. During turn-on, where the input of the driver is activated, the  $V_{CLAMP}$  function is disabled or opened.

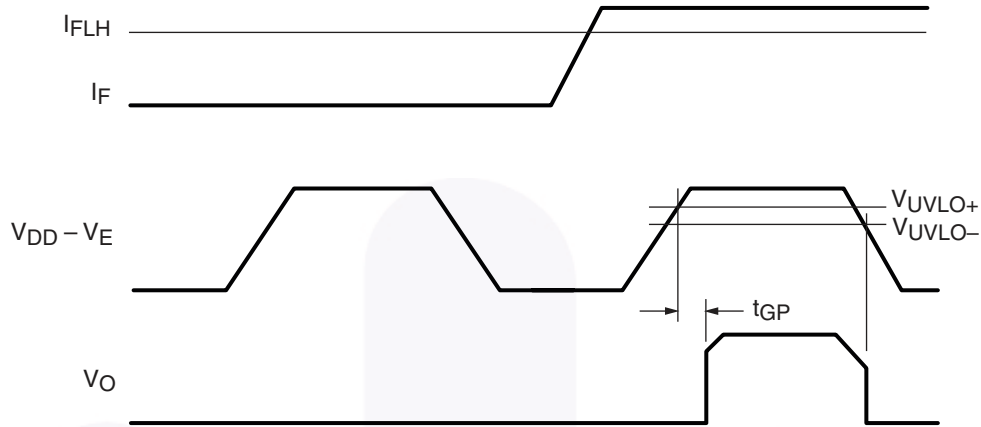


Figure 57. Time to Good Power

### 7. Time to Good Power

During fast power up (e.g. bootstrap power supply), the LED is off and the output of the gate driver should be in the LOW or OFF state. Sometimes, race conditions exist that cause the output to follow  $V_{DD}$  until all of the circuits in the output IC stabilize. This condition can result in output transitions or transients that are coupled to the driven IGBT. These glitches can cause the high- and low-side IGBTs to conduct shoot-through current that can damage the power semiconductor devices.

Fairchild has introduced a initial turn-on delay, called “time to good power.” This delay, typically  $2.0 \mu\text{s}$ , is only present during the initial power-up of the device. If the LED is ON during the initial turn-on activation, low-to-high transition at the output of the gate driver only occurs  $2.0 \mu\text{s}$  after the  $V_{DD}$  power is applied.

### 8. Dual Supply Operation – Negative Bias at $V_{SS}$

The IGBT’s off-state noise immunity can be enhanced by providing a negative gate-to-emitter bias when the IGBT is in OFF state. This static off-state bias can be supplied by connecting a separate negative voltage source between the  $V_E$  (pin 16) and  $V_{SS}$  (pin 9 and pin 12). The primary ground reference is the IGBT’s emitter connection,  $V_E$  (pin 16). The under-voltage lockout threshold and desaturation voltage detection are referenced to the IGBT’s emitter ( $V_E$ ) ground.

The negative voltage supply at  $V_{SS}$  appears at the gate drive output,  $V_O$ , when in LOW state. When the input drives the output HIGH, the output voltage,  $V_O$ , has the potential of the  $V_{DD}$  and  $V_{SS}$ . Proper power supply bypass capacitors are added to provide paths for the instantaneous gate charging and discharging currents. The Schottky diode is recommended connected between  $V_E$  and  $V_{SS}$  to protect against a reverse voltage greater than  $0.5 \text{ V}$ . The  $V_{CLAMP}$  (pin 10) should be connected to  $V_{SS}$  when not in use.

### 9. DESAT Pin Protection

During turn off, especially with inductive load, a large instantaneous forward-voltage transient can appear on the freewheeling diode of the IGBT. A large negative voltage spike on the DESAT pin can result and draw substantial current out of the gate driver IC if there is not current-limiting resistor. To limit this current, a  $100 \Omega$  to  $1 \text{ k}\Omega$  resistor should be inserted in series with the DESAT diode. The added resistance does not change the DESAT threshold or the DESAT blanking time.

The DESAT diode protects the gate driver IC from high voltages when the IGBT is turning off, while allowing a forward  $I_{CHG}$  current of  $250 \mu\text{A}$  to be conducted to sense the IGBT’s saturated collector to emitter voltage when the IGBT is turned on. A fast-recovery diode,  $t_{rr}$  below  $75 \text{ ns}$ , with sufficient reverse-voltage rating, should be used. Fairchild offers many of these ultra-fast diodes/rectifiers, such as ES1J-600V, with  $t_{rr}$  at  $35 \text{ ns}$ .

If two diodes or more are used, the required maximum reverse voltage can be reduced by half or accordingly. This modifies the trigger level for a fault condition. The sum of the DESAT diode forward-voltage and the IGBT collector-emitter  $V_{CE}$  voltage form the voltage at the DESAT pin. The trigger level for a fault condition given by:

$$V_{CE@FAULT} = V_{DESAT} - n \times V_F \quad (3)$$

where  $n$  is the number of the DESAT diodes.

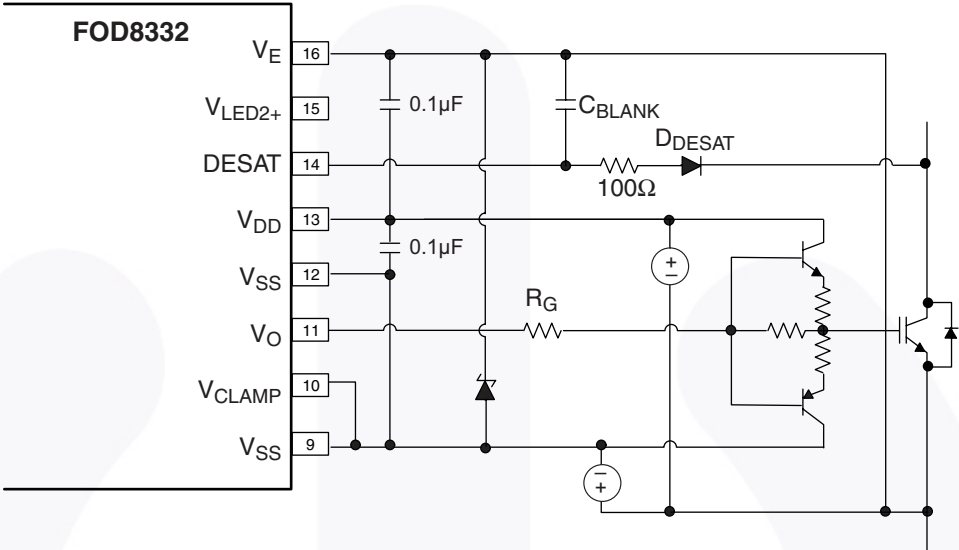
### 10. Pull-Up Resistor on FAULT Pin

The FAULT pin is an open-collector output and can be connected as wire-OR operation with other types of protection (e.g., over-temperature, over-voltage, over-current) to alert the microcontroller. Being an open-collector output, it requires a pull-up resistor to provide a normal high output voltage level. This resistor value must be properly considered based on various IC interface requirements. The sinking current capability is given by  $I_{FAULT}$ .

**11. Increasing the Output Drive Current Using an External Booster Stage**

If larger gate drive capability is needed for large IGBT modules or parallel operation, an output booster stage may be added to driver for optimum performance.


A possible implementation is by a discrete NPN/PNP totem-pole configuration. These booster transistors should be fast switching and have sufficient current gain to deliver the desired peak output current.



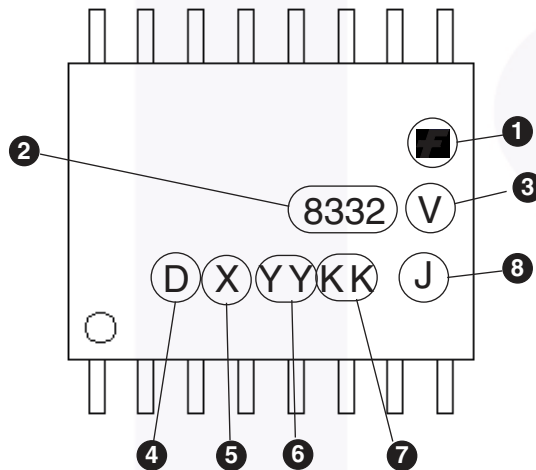
**Figure 58. Output Booster Stage for Increased Output Drive Current**

## Ordering Information

| Part Number | Package                                | Packing Method                     |
|-------------|----------------------------------------|------------------------------------|
| FOD8332     | SO 16-Pin                              | Tube (50 units per tube)           |
| FOD8332R2   | SO 16-Pin                              | Tape and Reel (750 units per reel) |
| FOD8332V    | SO 16-Pin, DIN EN/IEC 60747-5-5 option | Tube (50 units per tube)           |
| FOD8332R2V  | SO 16-Pin, DIN EN/IEC 60747-5-5 option | Tape and reel (750 units per reel) |

 All packages are lead free per JEDEC: J-STD-020B standard.

## Marking Information



### Definitions

|   |                                                                                 |
|---|---------------------------------------------------------------------------------|
| 1 | Fairchild logo                                                                  |
| 2 | Device number, e.g., '8332' for FOD8332                                         |
| 3 | DIN EN/IEC60747-5-5 Option (only appears on component ordered with this option) |
| 4 | Plant code, e.g., 'D'                                                           |
| 5 | Alphabetical year code, e.g., 'E' for 2014                                      |
| 6 | Two-digit work week ranging from '01' to '53'                                   |
| 7 | Lot traceability code                                                           |
| 8 | Package assembly code, e.g., 'J'                                                |

**Reflow Profile**

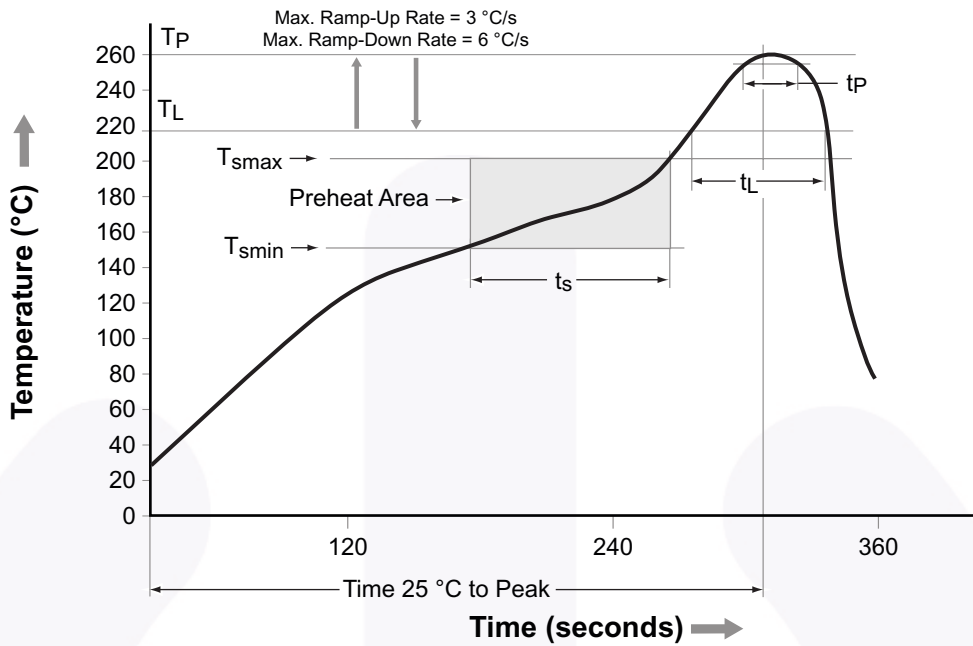
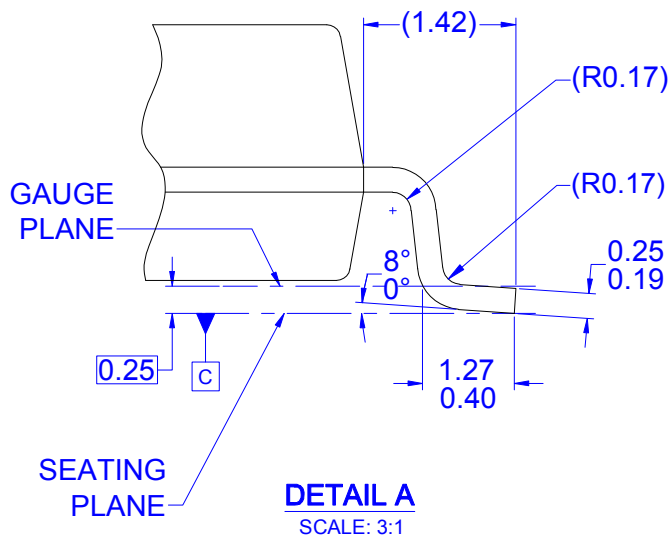
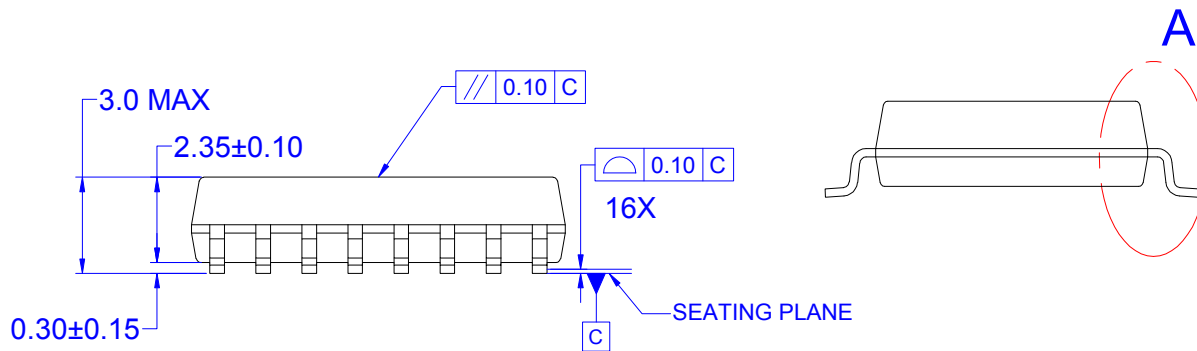
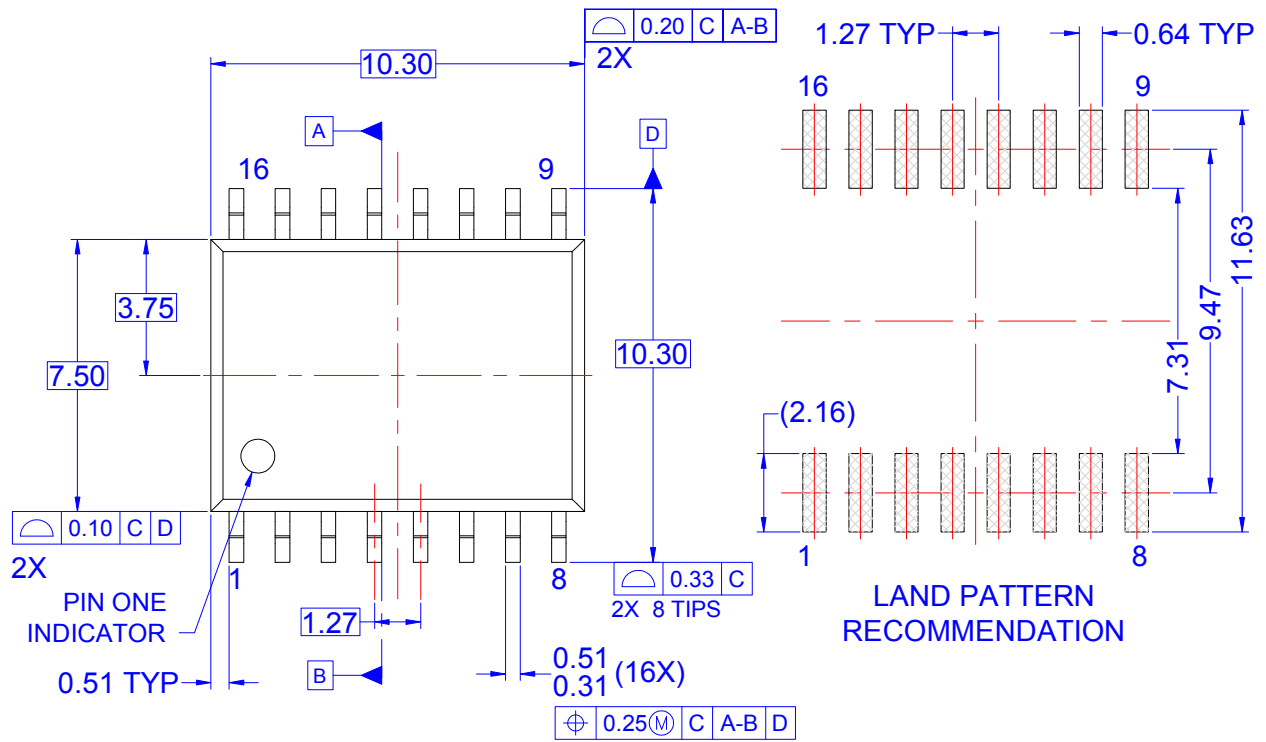


Figure 59. Reflow Profile

| Profile Feature                                  | Pb-Free Assembly Profile |
|--------------------------------------------------|--------------------------|
| Temperature Minimum ( $T_{smin}$ )               | 150°C                    |
| Temperature Maximum ( $T_{smax}$ )               | 200°C                    |
| Time ( $t_S$ ) from ( $T_{smin}$ to $T_{smax}$ ) | 60–120 seconds           |
| Ramp-up Rate ( $t_L$ to $t_P$ )                  | 3°C/second maximum       |
| Liquidous Temperature ( $T_L$ )                  | 217°C                    |
| Time ( $t_L$ ) Maintained Above ( $T_L$ )        | 60–150 seconds           |
| Peak Body Package Temperature                    | 260°C +0°C / -5°C        |
| Time ( $t_P$ ) within 5°C of 260°C               | 30 seconds               |
| Ramp-Down Rate ( $T_P$ to $T_L$ )                | 6°C/second maximum       |
| Time 25°C to Peak Temperature                    | 8 minutes maximum        |





NOTES: UNLESS OTHERWISE SPECIFIED

- A) DRAWING REFERS TO JEDEC MS-013, VARIATION AA.
- B) ALL DIMENSIONS ARE IN MILLIMETERS.
- C) DIMENSIONS ARE EXCLUSIVE OF BURRS, MOLD FLASH AND TIE BAR PROTRUSIONS
- D) DRAWING CONFORMS TO ASME Y14.5M-1994
- E) LAND PATTERN STANDARD: SOIC127P1030X275-16N
- F) DRAWING FILE NAME: MKT-M16FRE2

ON Semiconductor and  are trademarks of Semiconductor Components Industries, LLC dba ON Semiconductor or its subsidiaries in the United States and/or other countries. ON Semiconductor owns the rights to a number of patents, trademarks, copyrights, trade secrets, and other intellectual property. A listing of ON Semiconductor's product/patent coverage may be accessed at [www.onsemi.com/site/pdf/Patent-Marking.pdf](http://www.onsemi.com/site/pdf/Patent-Marking.pdf). ON Semiconductor reserves the right to make changes without further notice to any products herein. ON Semiconductor makes no warranty, representation or guarantee regarding the suitability of its products for any particular purpose, nor does ON Semiconductor assume any liability arising out of the application or use of any product or circuit, and specifically disclaims any and all liability, including without limitation special, consequential or incidental damages. Buyer is responsible for its products and applications using ON Semiconductor products, including compliance with all laws, regulations and safety requirements or standards, regardless of any support or applications information provided by ON Semiconductor. "Typical" parameters which may be provided in ON Semiconductor data sheets and/or specifications can and do vary in different applications and actual performance may vary over time. All operating parameters, including "Typicals" must be validated for each customer application by customer's technical experts. ON Semiconductor does not convey any license under its patent rights nor the rights of others. ON Semiconductor products are not designed, intended, or authorized for use as a critical component in life support systems or any FDA Class 3 medical devices or medical devices with a same or similar classification in a foreign jurisdiction or any devices intended for implantation in the human body. Should Buyer purchase or use ON Semiconductor products for any such unintended or unauthorized application, Buyer shall indemnify and hold ON Semiconductor and its officers, employees, subsidiaries, affiliates, and distributors harmless against all claims, costs, damages, and expenses, and reasonable attorney fees arising out of, directly or indirectly, any claim of personal injury or death associated with such unintended or unauthorized use, even if such claim alleges that ON Semiconductor was negligent regarding the design or manufacture of the part. ON Semiconductor is an Equal Opportunity/Affirmative Action Employer. This literature is subject to all applicable copyright laws and is not for resale in any manner.

## PUBLICATION ORDERING INFORMATION

### LITERATURE FULFILLMENT:

Literature Distribution Center for ON Semiconductor  
19521 E. 32nd Pkwy, Aurora, Colorado 80011 USA  
**Phone:** 303-675-2175 or 800-344-3860 Toll Free USA/Canada  
**Fax:** 303-675-2176 or 800-344-3867 Toll Free USA/Canada  
**Email:** [orderlit@onsemi.com](mailto:orderlit@onsemi.com)

**N. American Technical Support:** 800-282-9855 Toll Free  
USA/Canada  
**Europe, Middle East and Africa Technical Support:**  
Phone: 421 33 790 2910  
**Japan Customer Focus Center**  
Phone: 81-3-5817-1050

**ON Semiconductor Website:** [www.onsemi.com](http://www.onsemi.com)  
**Order Literature:** <http://www.onsemi.com/orderlit>  
For additional information, please contact your local  
Sales Representative