

LOC		DIST		REVISIONS			
P	LTR	DESCRIPTION	DATE	DMN	APVD		
B		REVISED PER ECO-11-000045	04JAN11	DH	DY		

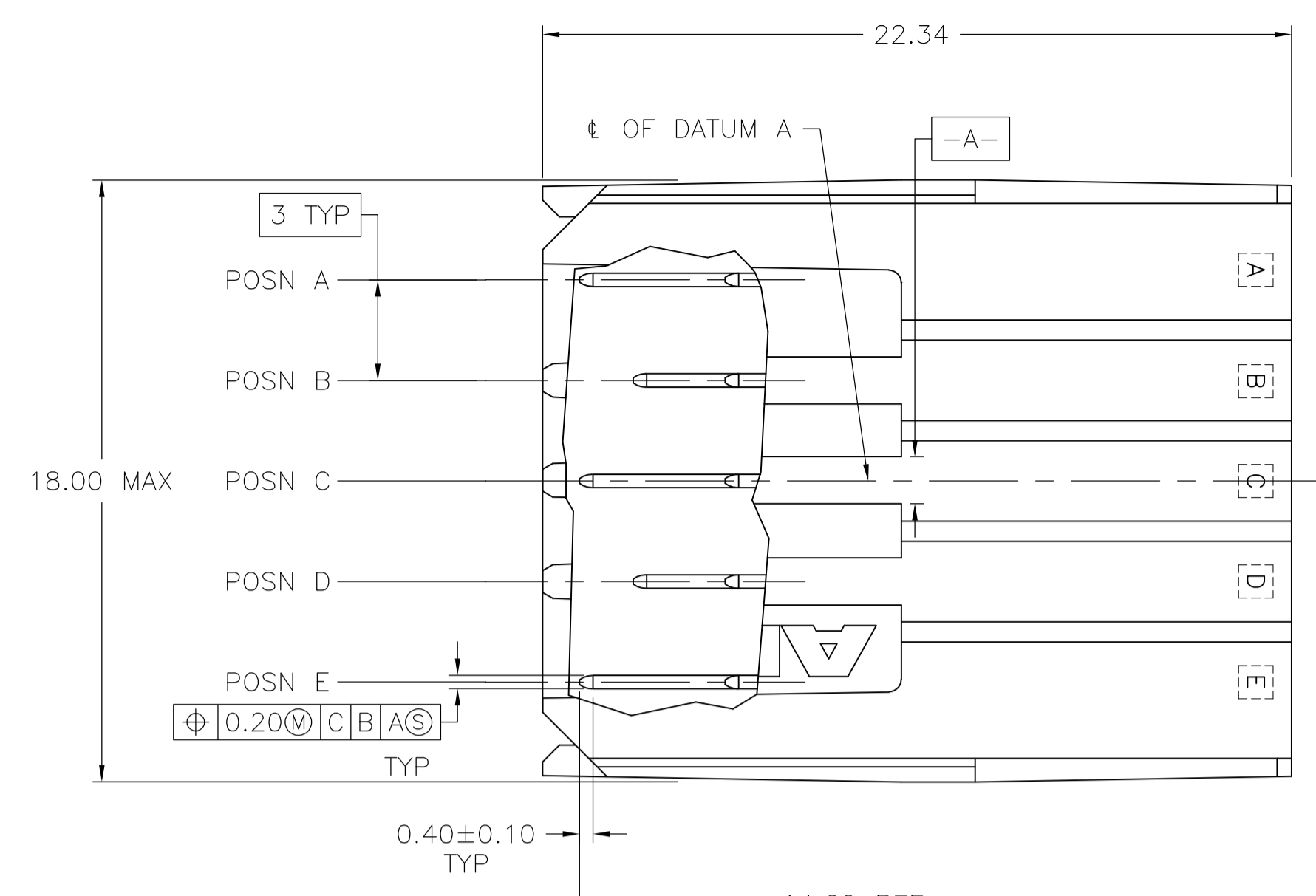

- 1 MATERIAL: HOUSING: POLYESTER, GRAY. UL 94V-0. CONTACT: HIGH CURRENT COPPER ALLOY.
- 2 FINISH: CONTACT MATING AREA: 1.27µm MIN GOLD OR 0.08µm MIN GOLD OVER 0.76µm MIN PALLADIUM-NICKEL. ACTION PIN AREA: 0.5µm MIN MATTE TIN PLATE, ALL OVER 1.27µm MIN NICKEL UNDERPLATE.
- 3 FINISH: CONTACT LUBRICATION WITH BELLCORE APPROVED LUBRICANT. TECHNICAL REFERENCE: GR-1217-CORE, ISSUE 1, NOVEMBER 1995.
- 4 10.26±0.13 DIMENSION APPLIES IN THIS AREA.
- 5 REFERENCE APPLICATION SPEC 114-1103 FOR RECOMMENDED PLATED THRU HOLE DIAMETER AND PLATING THICKNESSES.
6. CURRENT RATING 16A/CONTACT PER PRODUCT SPEC 108-1651.

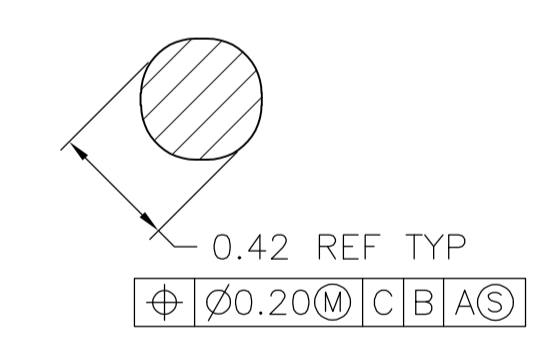
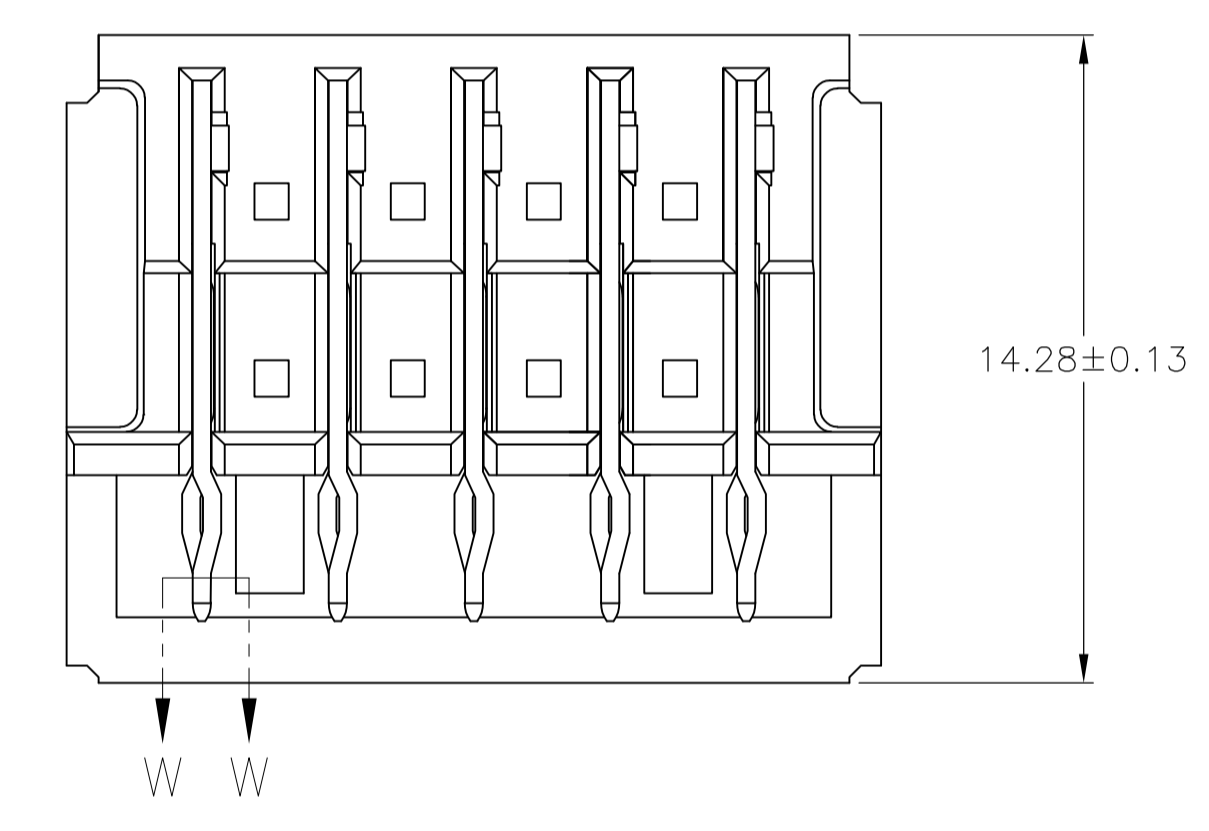
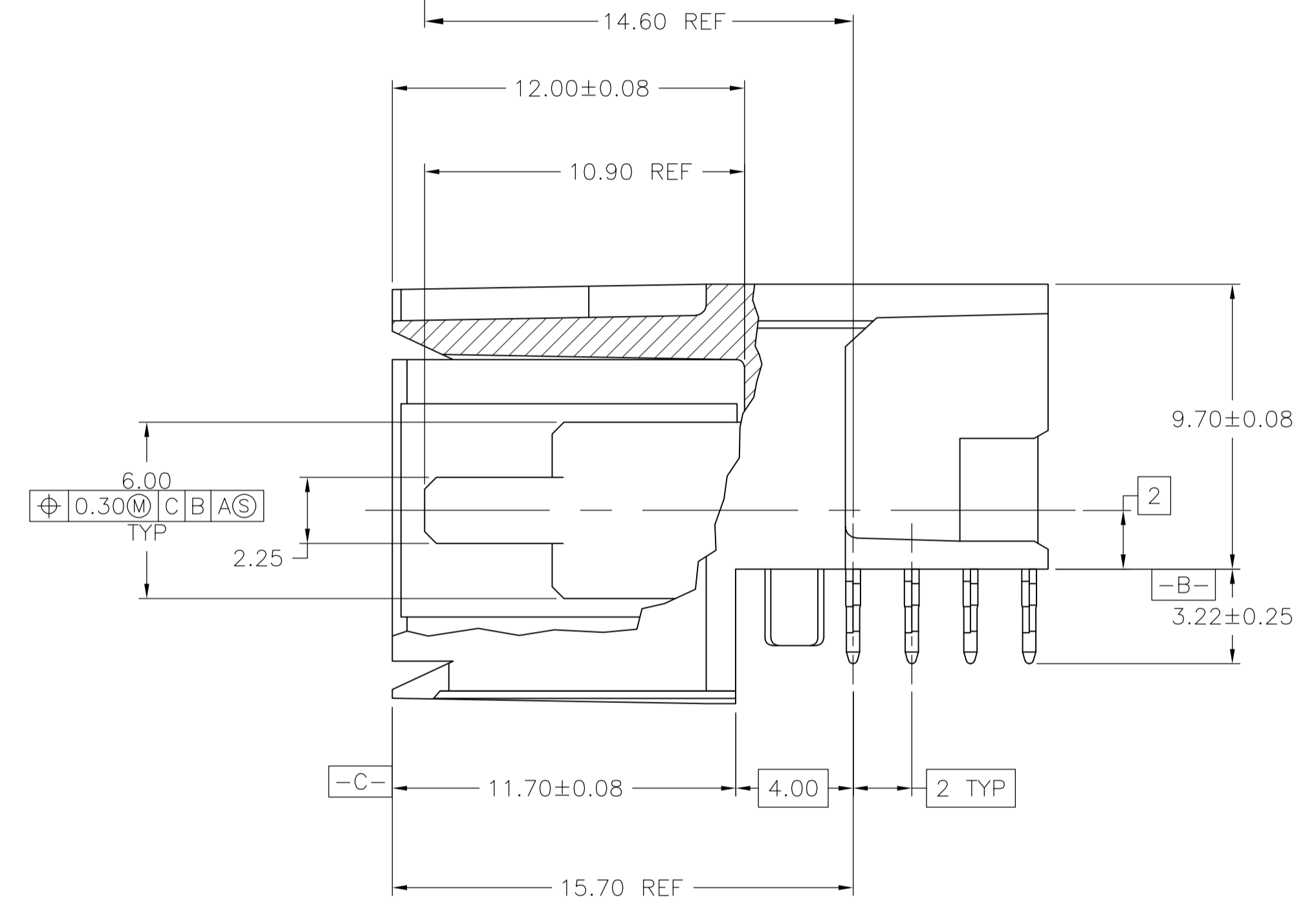
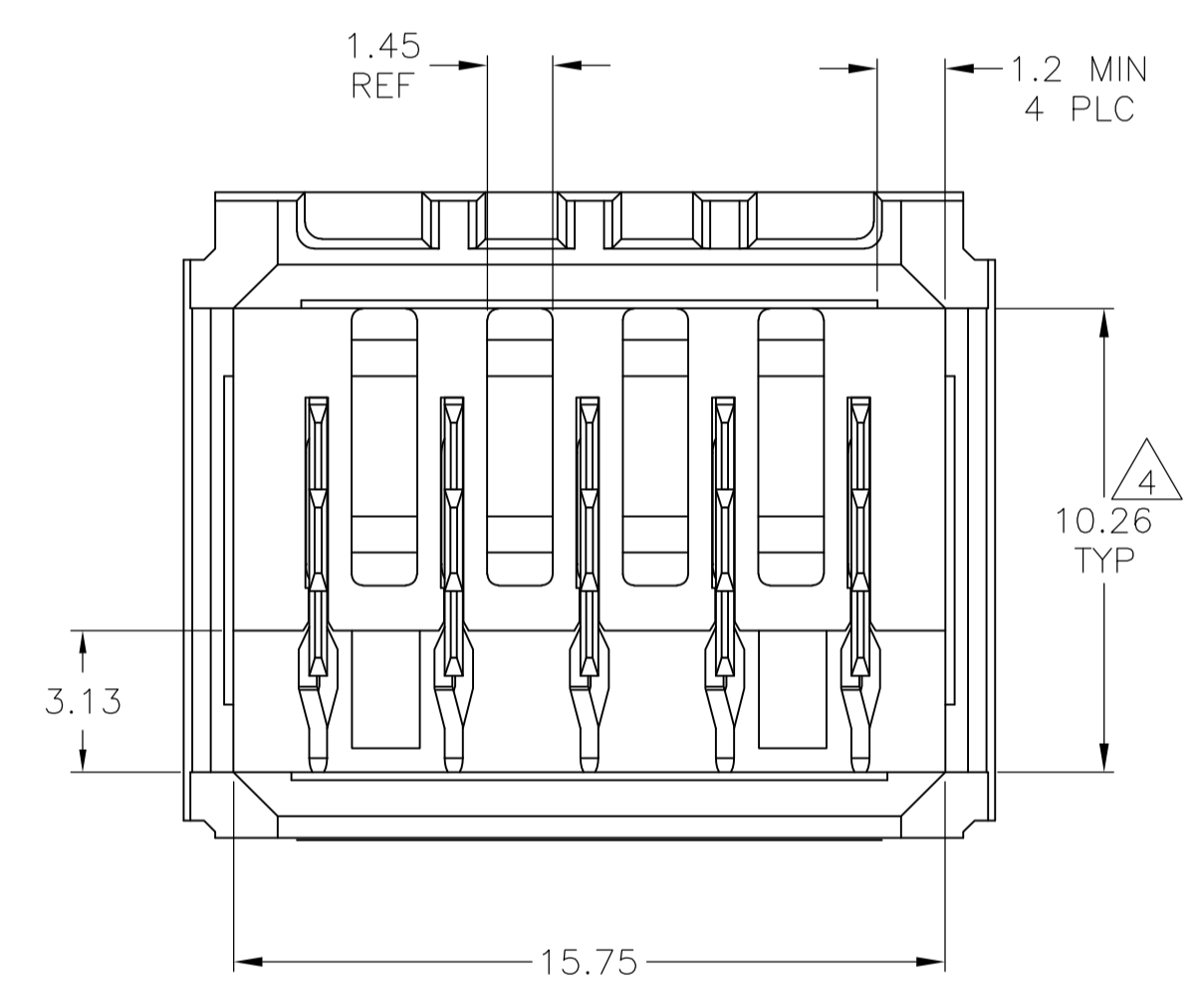

SECTION W-W  
SCALE 40:1

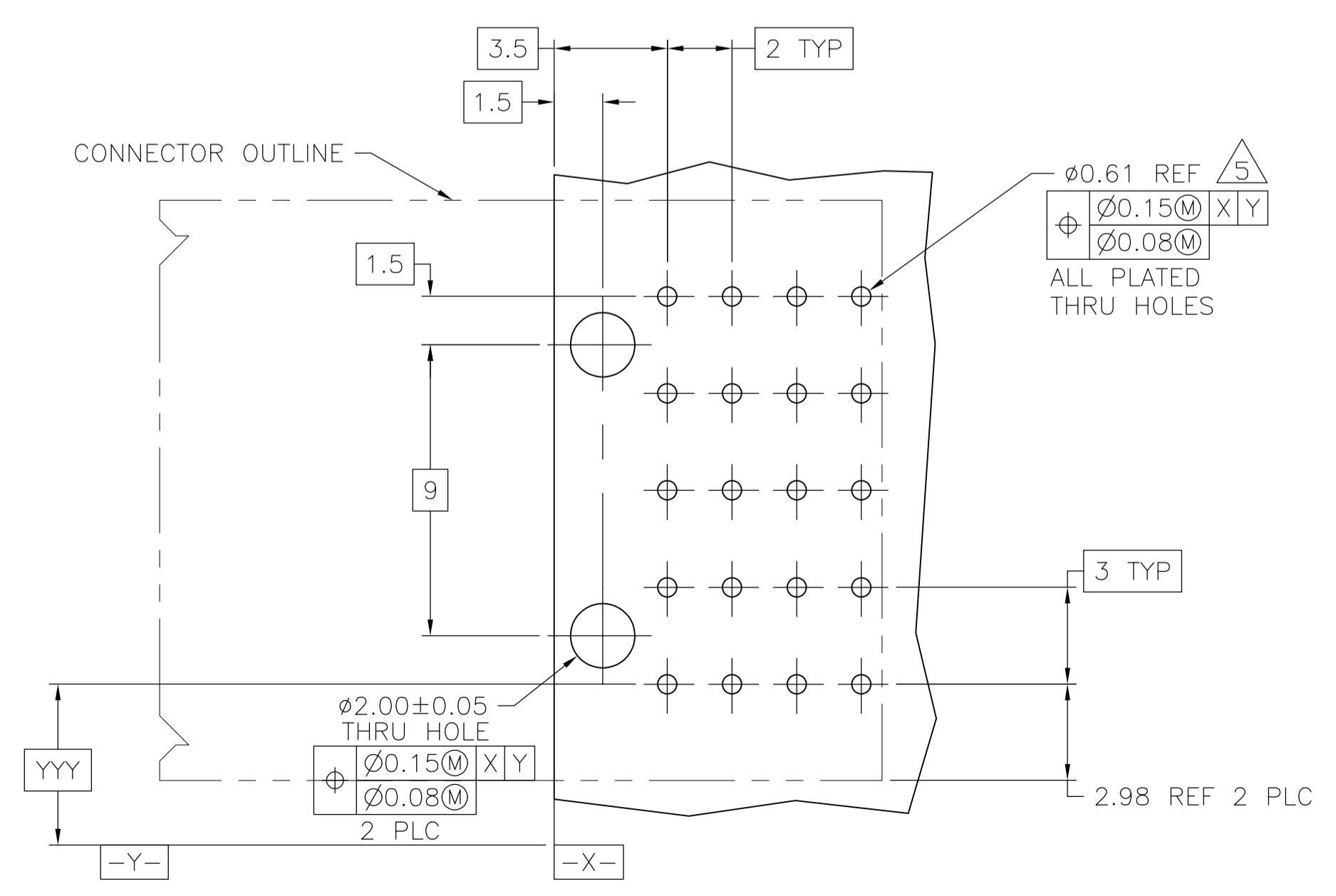

RECOMMENDED PCB HOLE LAYOUT

5-1645509-1  
PART NUMBER

THIS DRAWING IS A CONTROLLED DOCUMENT.		DIN D HUMBERT 04MAY2010	Tyco Electronics Corporation Harrisburg, PA 17105-3608	
DIMENSIONS: mm		CIK D YI 04MAY2010	NAME ASSEMBLY, RIGHT ANGLE HEADER, W/ RETENTION PEGS, UNIVERSAL POWER MODULE	
TOLERANCES UNLESS OTHERWISE SPECIFIED:		APVD D YI 04MAY2010	PRODUCT SPEC	
0 PLC ± -		APPLICATION SPEC		
1 PLC ± -		SIZE A1		
2 PLC ± 0.13		CAGE CODE 00779		
3 PLC ± -		DRAWING NO. 1645509		
4 PLC ± -		RESTRICTED TO		
ANGLES ± -		CUSTOMER DRAWING		
MATERIAL 1		FINISH 2 3		SCALE 6:1 SHEET 1 OF 1 REV B