

MATERIALS AND FINISHES:

SMA JACK
 BODY, FERRULE: BRASS
 PLATED: SEE TABLE

CENTER CONTACT: BERYLLIUM COPPER
 PLATED GOLD

INSULATOR: TEFLON

JAM NUT: BRASS
 PLATED: SEE TABLE

LOCKWASHER: SPCC OR EQUIVALENT
 PLATED: SEE TABLE

CABLE:
 RG178 CABLE OR EQUIVALENT

SHRINK TUBE: VERSAFIT OR EQUIVALENT
 BLACK COLOR

PACKAGING: BY POLYBAG

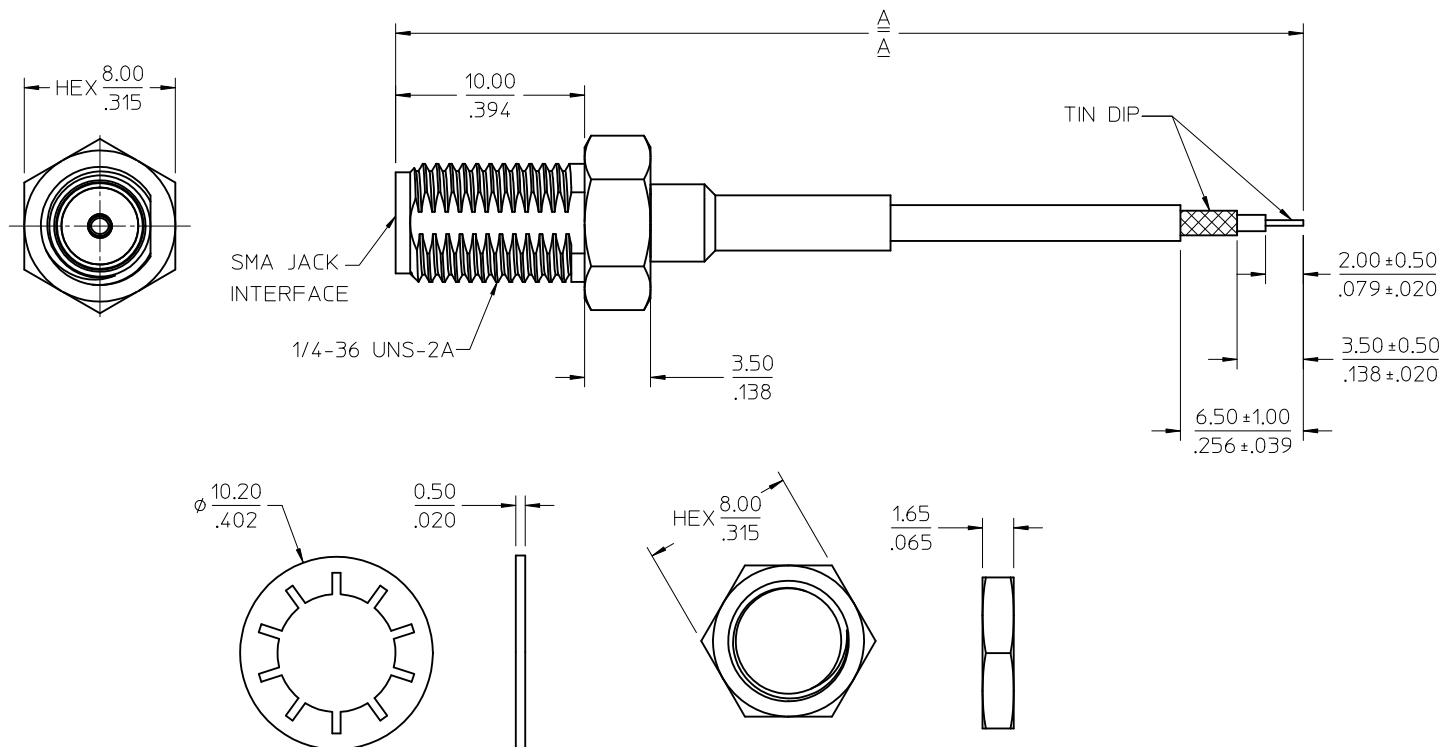
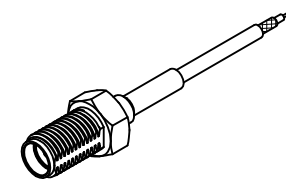

89761-1674	7.087±.197	180.00±5.00	GOLD
89761-1673	5.00±.197	127.00±5.00	GOLD
89761-1672	5.512±.197	140.00±5.00	GOLD
89761-1671	5.00±.197	127.00±5.00	NICKEL
89761-1670	5.00±.197	127.00±5.00	GOLD
PART NO.	IN	MM	PLATING
DIM	A		

MIL-STD-348A, FIG. 310.2	SMA INTERFACE
SPECIFICATION	DESCRIPTION

CHG: UPDATED MATERIAL FOR LOCK WASHER PER RF12-E045 EC NO: URF2012-0484 DRW:RYEH CHKD: APPR:HUANG 2012/02/10 2012/03/02	QUALITY SYMBOLS ▽=0 ▽=0	GENERAL TOLERANCES (UNLESS SPECIFIED)	DIMENSION STYLE MM/IN	SCALE	DESIGN UNITS METRIC	THIRD ANGLE PROJECTION	
		4 PLACES ± --- ± --- 3 PLACES ± --- ± --- 2 PLACES ± 0.13 ± --- 1 PLACE ± 0.25 ± ---	DRAWN BY DATE JOYCE 2005/12/29	CHECKED BY DATE KERRIE 2005/12/29	TITLE CA SMA JACK STR BKHD TO STRIP W/RG178 CABLE CA-SMAJ/STRIP		
		ANGULAR ± 2 °	APPROVED BY DATE MISEN 2005/12/29	MATERIAL NO. SEE TABLE	MOLEX INCORPORATED		
		DRAFT WHERE APPLICABLE MUST REMAIN WITHIN DIMENSIONS	SIZE C	THIS DRAWING CONTAINS INFORMATION THAT IS PROPRIETARY TO MOLEX INCORPORATED AND SHOULD NOT BE USED WITHOUT WRITTEN PERMISSION	DOCUMENT NO. SD-89761-167	SHEET NO. 1 OF 1	