

THIS DRAWING IS UNPUBLISHED. RELEASED FOR PUBLICATION  
 © COPYRIGHT - By - ALL RIGHTS RESERVED.

LOC	DIST	REVISIONS					
FT	0	P	LTR	DESCRIPTION	DATE	DWN	APVD
		Y		REVISED PER ECO-12-012316	05JUL12	KH	MZ

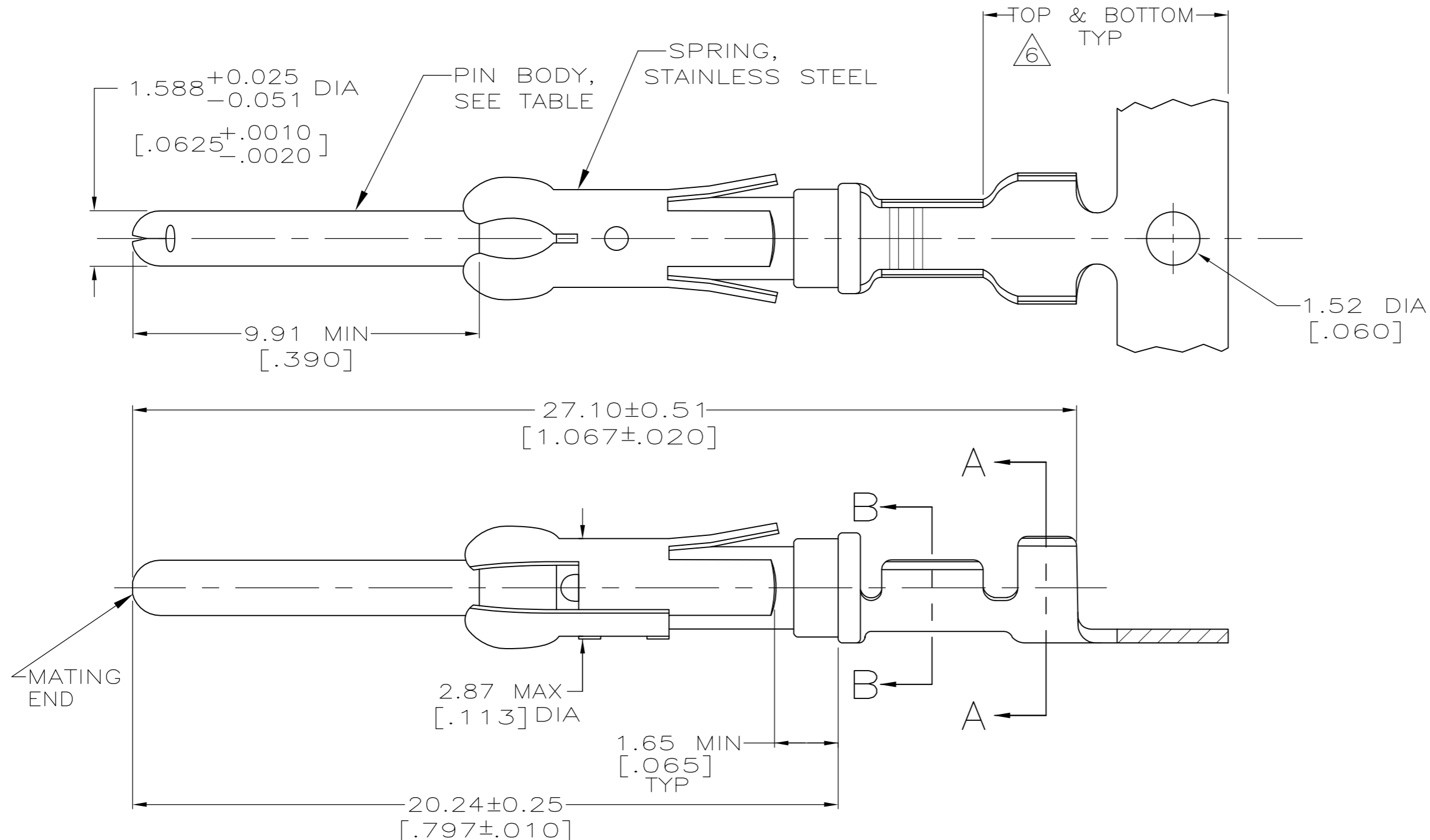

SECTION A-A

SECTION B-B

- 1 REVERSE REELED FOR MINI-APPLICATOR.
- 2 0.76µm [.000030] MIN PRECIOUS METAL PLATE ON MATING END FOR A LENGTH OF 5.08 [.200] MIN WITH 1.27µm [.000050] MIN MATTE TIN PLATE IN WIRE CRIMP AREA, BOTH OVER 1.27µm [.000050] MIN NICKEL PLATE. CONFORMS TO THE REQUIREMENTS OF TE CONNECTIVITY PRODUCT SPEC 108-10042, BASED ON EIA/ECA-364-1000.01A ( CONTROLLED ENVIRONMENT APPLICATIONS ).
- 3 0.76µm [.000030] MIN PRECIOUS METAL PLATE ON MATING END FOR A LENGTH OF 5.08 [.200] MIN WITH A UNIFORM GRADIENT TO 0.25µm [.000010] ON REMAINDER, OVER 1.27µm [.000050] MIN NICKEL PLATE. GOLD FLASH ALL OVER. CONFORMS TO THE REQUIREMENTS OF TE CONNECTIVITY PRODUCT SPEC 108-10042, BASED ON EIA/ECA-364-1000.01A ( CONTROLLED ENVIRONMENT APPLICATIONS ).
- 4 0.38µm [.000015] MIN GOLD PER MIL-G-45204 ON MATING END FOR A LENGTH OF 5.08 [.200] MIN WITH 1.27µm [.000050] MIN MATTE TIN PLATE IN WIRE CRIMP AREA, BOTH OVER 1.27µm [.000050] MIN NICKEL PER QQ-N-290.
- 5 1.27µm [.000050] MIN GOLD PER MIL-G-45204 ON MATING END FOR A LENGTH OF 5.08 [.200] MIN WITH GOLD FLASH ON THE REMAINDER OVER 3.81µm [.000150] MIN NICKEL PER QQ-N-290.
- 6 GOLD PLATING NEED NOT APPEAR IN THIS AREA.
- 7 1.27µm [.000050] MIN TIN-LEAD PER MIL-T-10727 OVER 1.27µm [.000050] MIN NICKEL PER QQ-N-290.
- 8 WIRE RANGE 24-20 AWG.
- 9 INSULATION RANGE 2.03 [.080]-2.54 [.100] DIA.
- 10 0.38µm [.000015] MIN GOLD PER MIL-G-45204 ON MATING END FOR A LENGTH OF 5.08 [.200] MIN, 1.27µm [.000050] MIN TIN-LEAD PER MIL-T-10727 FOR A LENGTH OF 5.69 [.224] MIN ON OPPOSITE END, BOTH OVER 1.27µm [.000050] MIN NICKEL PER QQ-N-290 ON ENTIRE CONTACT.
- 11 1.27µm [.000050] MIN TIN PER MIL-T-10727 OVER 1.27µm [.000050] MIN NICKEL PER QQ-N-290.
- 12 OBSOLETE PARTS: OBSOLETE CIS STREAMLINING PER D.RENAUD/D.SINISI

12	OBSOLETE	STANDARD	1	1	BRASS	1-66400-0	1-66332-5
			1	1	BRASS	1-66400-0	1-66332-4
12	OBSOLETE		1	2	PHOSPHOR BRONZE	-	1-66332-3
	OBSOLETE		1	10	BRASS	66400-5	1-66332-2
	OBSOLETE		1	5	BRASS	-	1-66332-1
			1	2	BRASS	66400-4	66332-8
			1	4	BRASS	66400-3	66332-7
			1	3	BRASS	66400-2	66332-6
			1	7	BRASS	66400-1	66332-5
		STANDARD		2	BRASS	66400-4	66332-4
		STANDARD		4	BRASS	66400-3	66332-3
		STANDARD		7	BRASS	66400-1	66332-1
		REELING			PIN BODY FINISH		
					PIN BODY		
					LOOSE PIECE REF		
							PART NO

THIS DRAWING IS A CONTROLLED DOCUMENT.

DIMENSIONS: mm [INCHES]	TOLERANCES UNLESS OTHERWISE SPECIFIED: 0 PLC ± - 1 PLC ± - 2 PLC ± 0.13 [.005] 3 PLC ± - 4 PLC ± - ANGLES ± -	DWN R.SHIREY 7-18-91 CHK R.STONE 8-15-91 APVD J.WESTMAN 8-19-91		
MATERIAL SEE CALLOUTS	FINISH SEE TABLE	PRODUCT SPEC APPLICATION SPEC WEIGHT -	NAME CONTACT, PIN, .062, TYPE III+ SIZE A2 CAGE CODE 00779 DRAWING NO C=66332 RESTRICTED TO - SCALE 8:1 SHEET 1 OF 1 REV Y	
CUSTOMER DRAWING				