

43V 4-CH LED Driver

General Description

The RT8510 is a high efficiency driver for white LEDs. It is designed for LCD panels that employ an array of LEDs as the lighting source. An integrated switch current mode boost controller drives four strings in parallel and supports up to 12 pieces of LED per string. The internal current sinks support a maximum of $\pm 2\%$ current mismatching for excellent brightness uniformity in each string of LED. To provide enough headroom for current sink operation the boost controller monitors the minimum voltage of feedback pins and regulates an optimized output voltage for power efficiency.

The RT8510 has a wide input voltage range from 4.2V to 24V and provide an adjustable 10mA to 40mA LED current. The internal 200m Ω , 43V power switch with current-mode control provides cycle-by-cycle over current protection. The RT8510 also integrates PWM dimming function for accurate LED current control. The input PWM dimming frequency can operate from 120Hz to 30kHz without inducing any inrush current through the LED or inductor. The switching frequency of the RT8510 is adjustable from 500kHz to 2MHz, allowing the user flexibility between efficiency and component size.

The RT8510 is available in a WQFN-16L 3x3 package.

Ordering Information

RT8510□□

- Package Type
QW : WQFN-16L 3x3 (W-Type)
- Lead Plating System
G : Green (Halogen Free and Pb Free)
Z : ECO (Ecological Element with Halogen Free and Pb free)

Note :

Richtek products are :

- ▶ RoHS compliant and compatible with the current requirements of IPC/JEDEC J-STD-020.
- ▶ Suitable for use in SnPb or Pb-free soldering processes.

Features

- Wide Input Voltage : 4.2V to 24V
- High Output Voltage : Up to 43V
- Adjustable Channel Current : 10mA to 40mA
- Channel Current Accuracy : $\pm 3\%$
- Channel Current Matching : $\pm 2\%$
- PWM Dimming Frequency : 120Hz to 30kHz
- Adjustable Switching Frequency : 500kHz to 2MHz
- Built-In Soft-Start
- Disconnects LED in Shutdown
- Open Current Sink Detection
- Adjustable Over Voltage Protection
- Over Temperature Protection
- Current Limit Protection
- Thin 16-Lead WQFN Package
- RoHS Compliant and Halogen Free

Applications

- UMPC and Notebook Computer Backlight
- GPS, Portable DVD Backlight

Pin Configuration

(TOP VIEW)

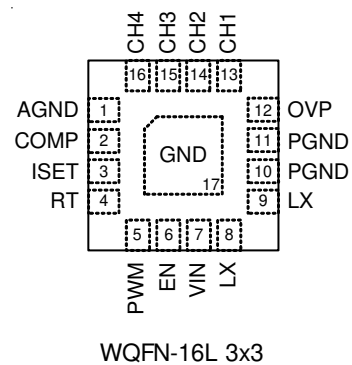

Marking Information

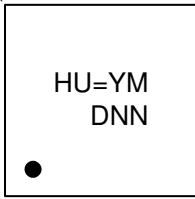

HU= : Product Code
YMDNN : Date Code

Typical Application Circuit

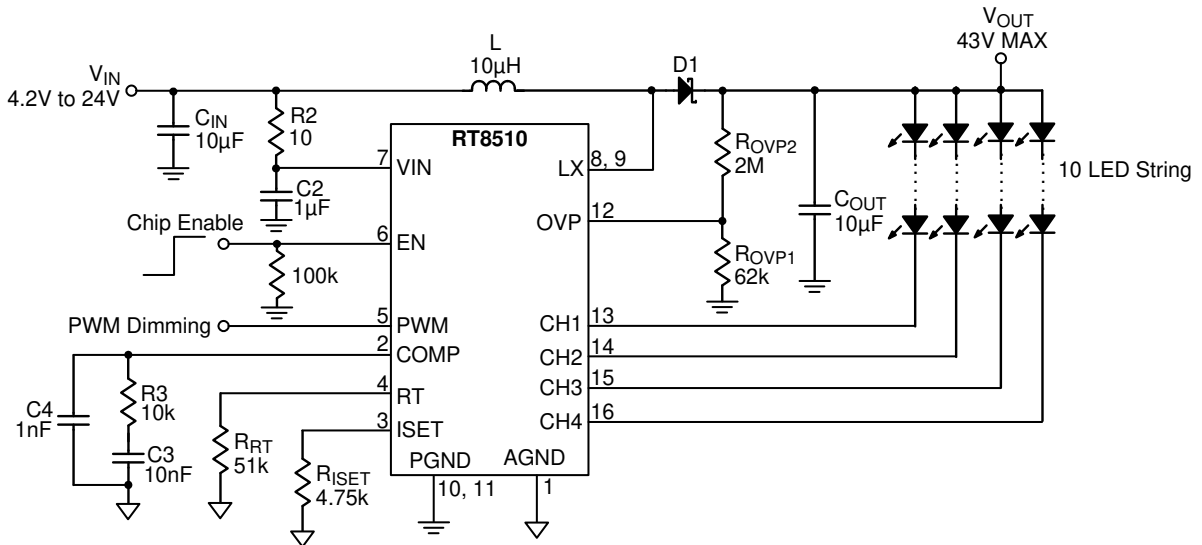

Figure 1. General Application Circuit

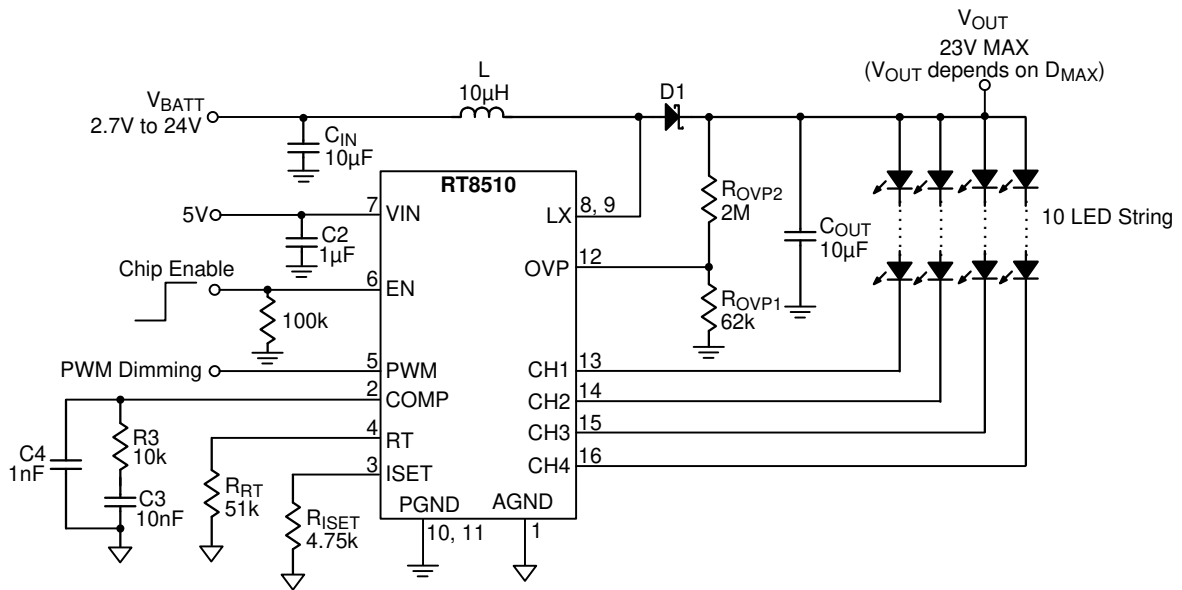
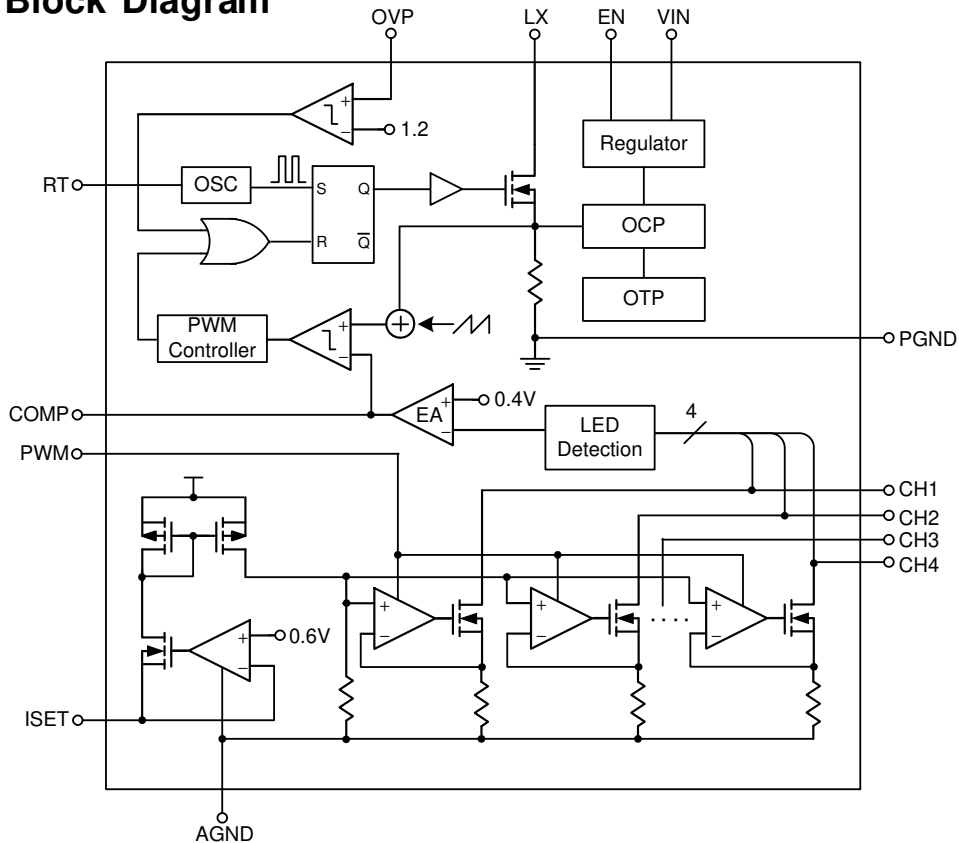

Figure 2. Low Input Voltage Application Circuit

Functional Pin Description

Pin No.	Pin Name	Pin Function
1	AGND	Analog ground of LED driver.
2	COMP	Compensation pin for error amplifier. Connect a compensation network to ground.
3	ISET	LED current set pin. LED current is set by the value of the resistor R_{ISET} connected from the ISET pin to ground. Do not short the ISET pin. V_{ISET} is typically 0.6V. $I_{LED} = \frac{95}{R_{ISET}}$
4	RT	Frequency adjust pin. This pin allows setting the switching frequency with a resistor to 500kHz to 2MHz.
5	PWM	Dimming control input.
6	EN	Chip enable (Active High). Note that this pin is high impedance. There should be a pull low 100kΩ resistor connected to GND when the control signal is floating.
7	VIN	Power supply input.
8, 9	LX	Switching pin of boost converter.
10, 11	PGND	Power ground of boost converter.
12	OVP	Sense input for over voltage protection. The detecting threshold is 1.2V.
13, 14, 15, 16	CH1 to CH 4	Current sink for LED. Leave the pin unconnected, if not used.
17 (Exposed Pad)	GND	The exposed pad must be soldered to a large PCB and connected to GND for maximum power dissipation.

Functional Block Diagram



Absolute Maximum Ratings (Note 1)

- Supply Input Voltage to GND ----- -0.3V to 26.5V
- EN, PWM, ISET, COMP, RT to GND ----- -0.3V to 26.5V
- LX, OVP, CH1, CH2, CH3, CH4 to GND ----- -0.3V to 48V
- Power Dissipation, P_D @ $T_A = 25^\circ\text{C}$
 - WQFN-16L 3x3 ----- 1.471W
- Package Thermal Resistance (Note 2)
 - WQFN-16L 3x3, θ_{JA} ----- 68°C/W
 - WQFN-16L 3x3, θ_{JC} ----- 7.5°C/W
- Lead Temperature (Soldering, 10 sec.) ----- 260°C
- Junction Temperature ----- 150°C
- Storage Temperature Range ----- -65°C to 150°C
- ESD Susceptibility (Note 3)
 - HBM ----- 2kV
 - MM ----- 200V

Recommended Operating Conditions (Note 4)

- Supply Input Voltage, V_{IN} ----- 4.2V to 24V
- Junction Temperature Range ----- -40°C to 125°C
- Ambient Temperature Range ----- -40°C to 85°C

Electrical Characteristics

($V_{IN} = 4.5\text{V}$, $T_A = 25^\circ\text{C}$ unless otherwise specified)

Parameter	Symbol	Test Conditions	Min	Typ	Max	Unit	
VIN Quiescent Current	I_Q	$V_{COMP} = 0\text{V}$, no switching	0.7	1	1.5	mA	
		$V_{COMP} = 2\text{V}$, switching	1.6	2	3		
VIN Shutdown Current	I_{SHDN}	$V_{IN} = 4.5\text{V}$, $EN = 0\text{V}$	0.01	--	10	μA	
VIN Under Voltage Lockout	UVLO	Rising	2.07	2.3	2.53	V	
		Falling	1.98	2.2	2.42		
Control Input							
EN Threshold Voltage	Logic-High	V_{IH}	$V_{IN} = 4.2\text{V}$ to 24V	2	--	--	V
	Logic-Low	V_{IL}		--	--	0.8	
PWM Threshold Voltage	Logic-High	V_{IH}	$V_{IN} = 4.2\text{V}$ to 24V	1.5			
	Logic-Low	V_{IL}				0.6	
PWM Dimming Frequency	f_{PWM}		120	--	30k	Hz	
EN, PWM Leakage Current	I_{LKG}		2	--	6	μA	
EN Shutdown Delay	t_{EN}	$R_{RT} = 51\text{k}\Omega$	28	32	36	ms	
Boost Converter							
Switching Frequency	f_{OSC}	$R_{RT} = 25\text{k}\Omega$	1.65	1.94	2.23	MHz	
		$R_{RT} = 51\text{k}\Omega$	0.94	1.1	1.27		
		$R_{RT} = 102\text{k}\Omega$	0.48	0.57	0.66		

Parameter	Symbol	Test Conditions	Min	Typ	Max	Unit
LX On Resistance (N-MOSFET)	R _{DS(ON)_N}	V _{IN} > 4.5V	0.18	0.25	0.33	Ω
Minimum ON Time	t _{MON}		59	90	121	ns
Maximum Duty	D _{MAX}	V _{COMP} = 2V, switching	85	90	95	%
LX Current Limit	I _{LIM}		1.5	2	2.7	A
LED Current Programming						
LED Current Matching	I _{LEDM}	2V > CH _x > 0.4V calculating (I _(MAX) - I _(AVG)) / I _(AVG) × 100%, R _{ISET} = 4.75kΩ	-2	--	2	%
LED Current Accuracy	I _{LEDA}	2V > CH _x > 0.4V calculating (I _{CH} - I _{SET}) / I _{SET} × 100%, R _{ISET} = 4.75kΩ	-3		3	%
ISET Pin Voltage	V _{ISET}		0.56	0.6	0.64	V
LED Current	I _{CHx}	2V > CH _x > 0.4V, R _{ISET} = 4.75kΩ	19.4	20	20.6	mA
Fault Protection						
OVP Threshold	V _{OVP}		1.16	1.2	1.24	V
OVP Fail Threshold	V _{OVPF}		33	55	77	mV
Thermal Shutdown Temperature	T _{SD}		145	160	175	°C
LED Pin Under Voltage Threshold	V _{LSD}	No connection	18	60	100	mV
Regulated V _{CHx}	V _{CHx}	Highest LED string voltage, R _{ISET} = 4.75kΩ	0.3	0.4	0.5	V

Note 1. Stresses beyond those listed “Absolute Maximum Ratings” may cause permanent damage to the device. These are stress ratings only, and functional operation of the device at these or any other conditions beyond those indicated in the operational sections of the specifications is not implied. Exposure to absolute maximum rating conditions may affect device reliability.

Note 2. θ_{JA} is measured under natural convection (still air) at T_A = 25°C with the component mounted on a high effective-thermal-conductivity four-layer test board on a JEDEC 51-7 thermal measurement standard. θ_{JC} is measured at the exposed pad of the package.

Note 3. Devices are ESD sensitive. Handling precaution is recommended.

Note 4. The device is not guaranteed to function outside its operating conditions.

Note 5. Guaranteed by design; not subject to production testing.

Typical Operating Characteristics

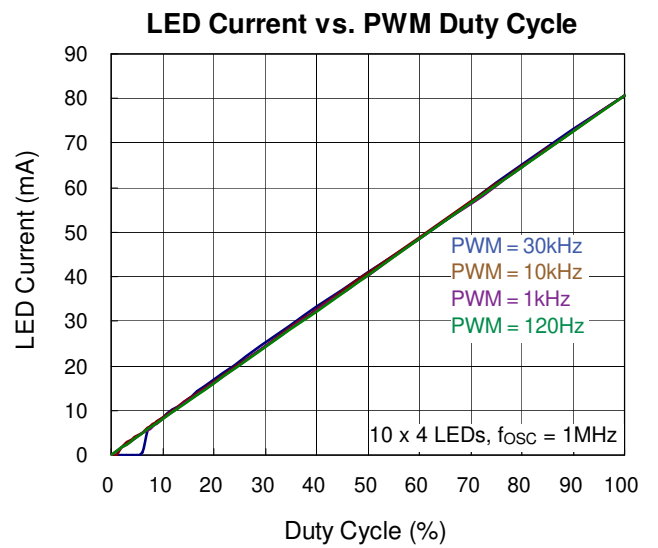
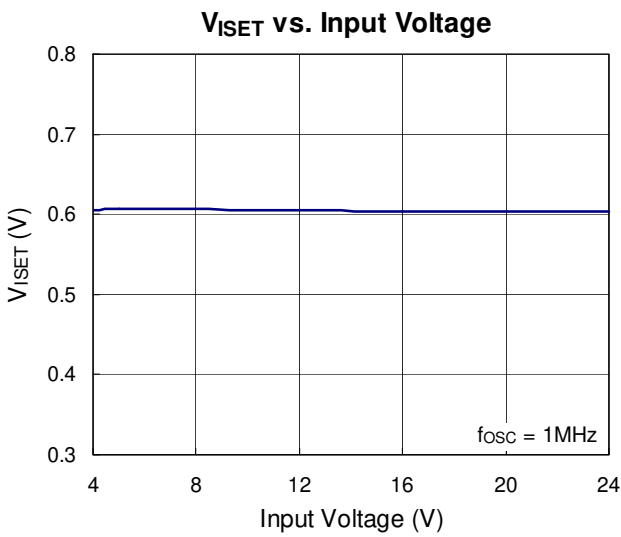
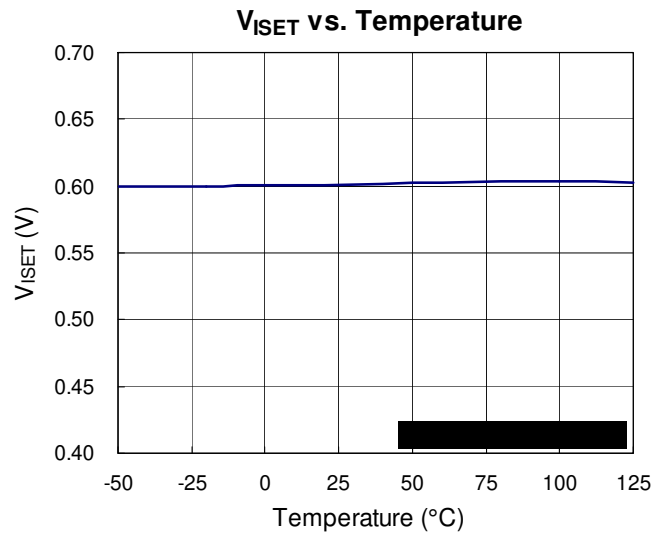
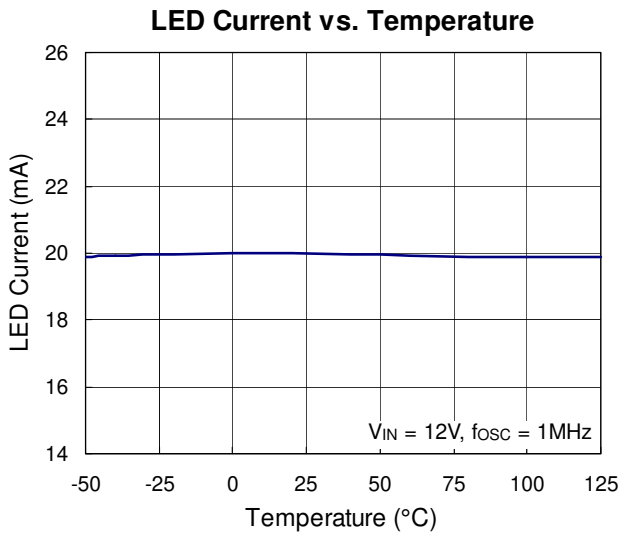
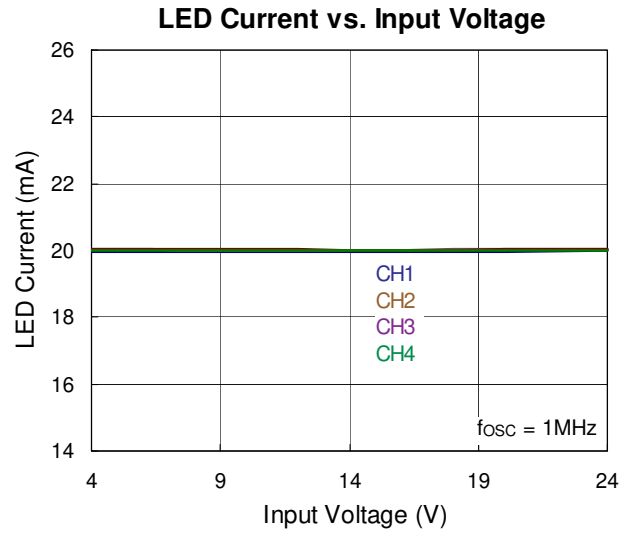
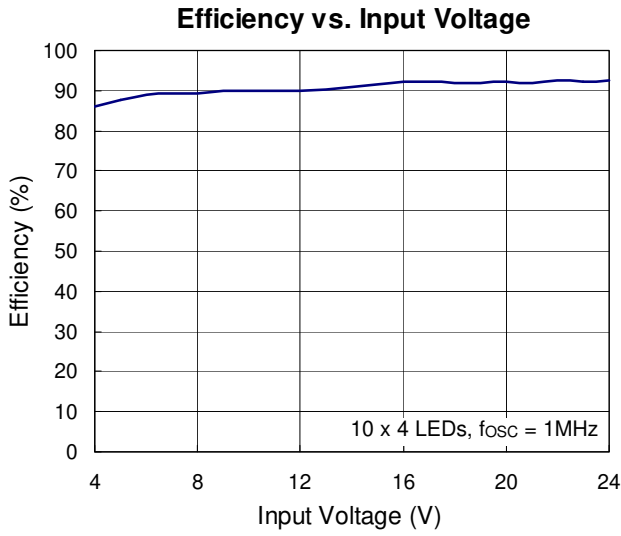

OVP Threshold vs. Input Voltage

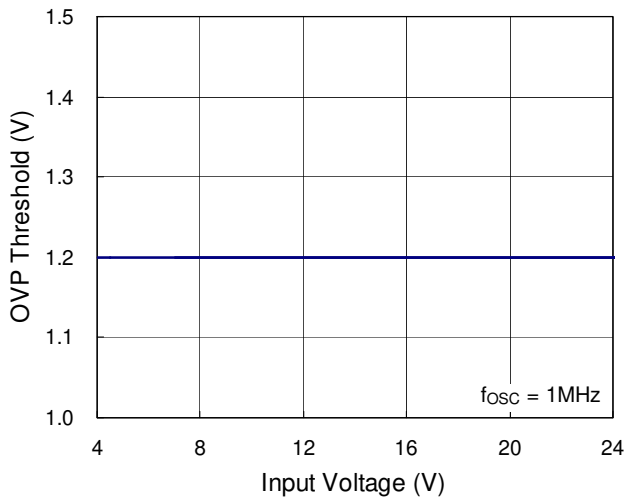

Switch Off Current vs. Temperature

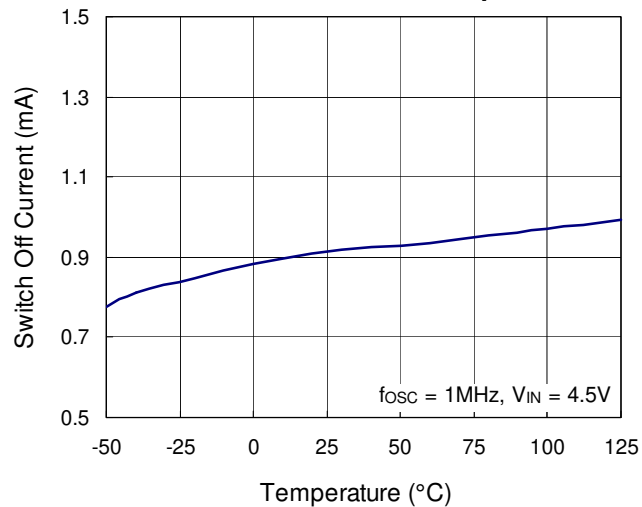

Line Transient Response

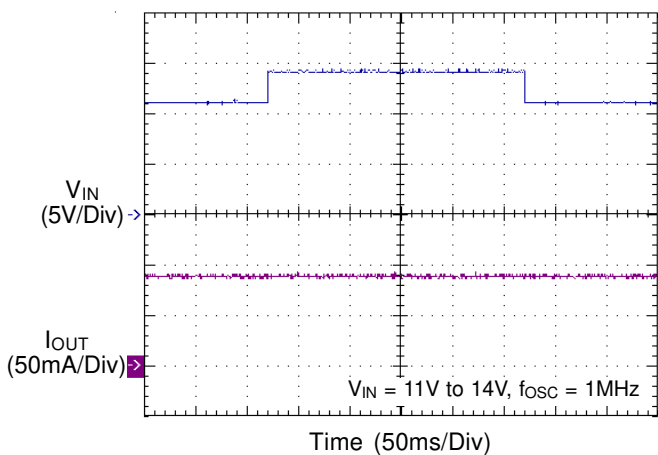

Line Transient Response

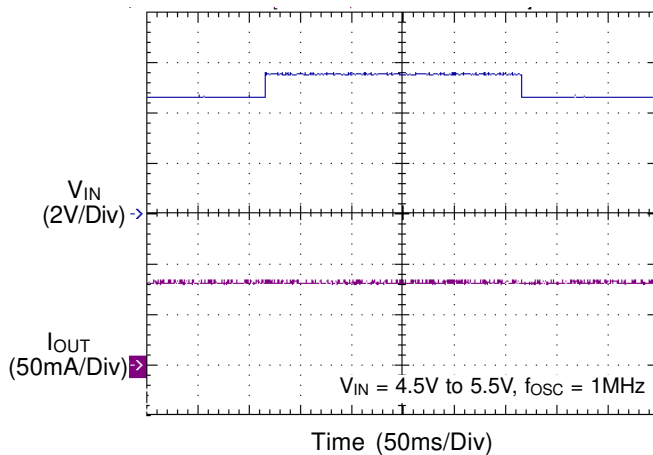

Application Information

The RT8510 is a general purpose 4-CH LED driver capable of delivering an adjustable 10 to 40mA LED current. The IC is a current mode boost converter integrated with a 43V/2A power switch and can cover a wide V_{IN} range from 4.2V to 24V. The switching frequency is adjustable by an external resistor from 500kHz to 2MHz. The part integrates built-in soft start, with PWM dimming control; moreover, it provides over voltage, over temperature and current limiting protection features.

Soft-Start

The RT8510 equips a built-in soft-start feature to prevent high inrush current during start-up. The soft-start function prevents excessive input current and input voltage droop during power on state.

Compensation

The control loop can be compensated by adjusting the external components connected to the COMP pin. The COMP pin is the output of the internal error amplifier. The compensation capacitors, C3 and C4, will adjust the integrator zero and pole respectively to maintain stability. Moreover, the resistor, R3, will adjust the frequency integrator gain for fast transient response.

Switching Frequency

The LED driver switching frequency is able to adjusted as the following equation :

$$f_{OSC} \cong \frac{51k}{R_{RT}} \text{ (MHz)}$$

LED Connection

The RT8510 equips 4-CH LED drivers with each channel supporting up to 12 LEDs. The LED strings are connected from the output of the boost converter to pins 13, 14, 15 and 16 respectively. If one of the LED channel is not used, the LED pin should be opened directly.

Light Load Mode

When the input voltage is close to the output voltage, V_{OUT} ripple will increase. The V_{OUT} should be set at higher than $1.2 \times V_{IN}$. If duty pulse is close to minimum on-time and smaller than 120ns, the duty pulse will be skipped. Figure 3 shows the timing diagram with skipped pulse.

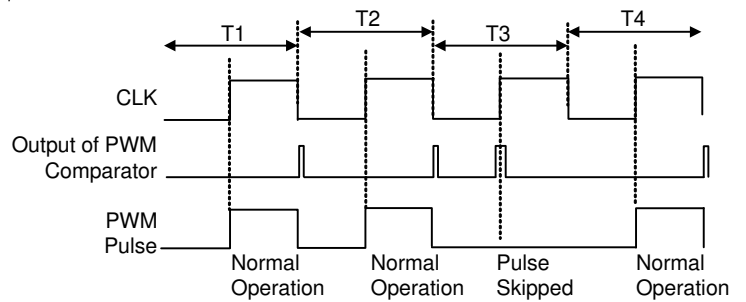

Figure 3. Pulse Skip Mode

Setting and Regulation of LED Current

The LED current can be calculated by the following equation :

$$I_{LED} \cong \frac{95}{R_{ISET}}$$

where R_{ISET} is the resistor between the ISET pin and GND. This setting is the reference for the LED current at channel 1-4 and represents the sensed LED current for each string. The DC/DC converter regulates the LED current according to R_{ISET} .

Power Sequence

LED Driver is without power sequence concern. Figure 4, Figure 5 and Figure 6 are different power sequences respectively. There is no concern in the above condition.

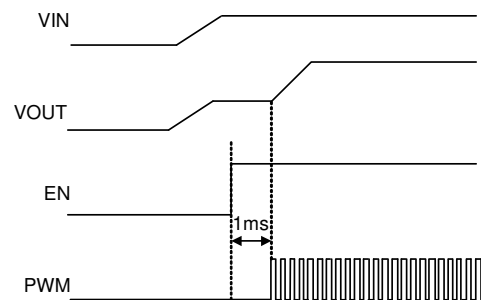

Power On Mode 1

Figure 4

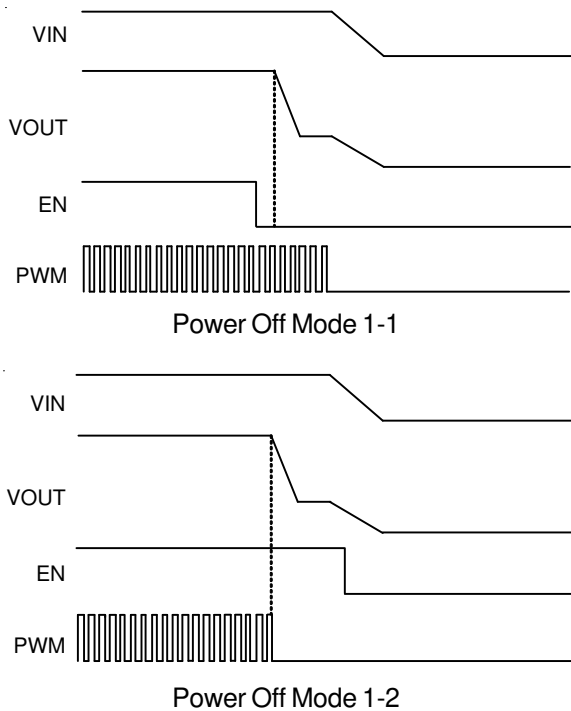

Figure 5

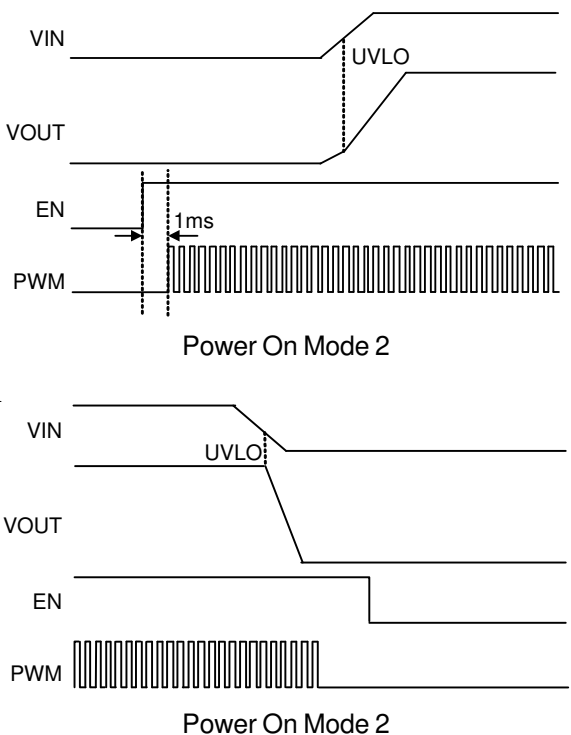

Figure 6

Over Voltage Protection

The RT8510 integrates over voltage protection (OVP) function. When the voltage at the OVP pin reaches the threshold voltage, the internal switch will be turned off. The internal switch will be turned on again once the voltage at OVP pin drops below its threshold voltage.

The OVP threshold voltage is adjustable and can be clamped at a certain voltage level and it can be calculated by the following equation :

$$V_{OUT(OVP)} = V_{OVP} \times \left(1 + \frac{R_{OVP2}}{R_{OVP1}} \right)$$

where $V_{OVP} = 1.2V$ (typ.).

R_{OVP1} and R_{OVP2} are the resistors in the voltage divider connected to the OVP pin. If at least one string is in normal operation, the controller will automatically ignore the open strings and continue to regulate the current for the strings in normal operation. It is suggested to use $2M\Omega$ for R_{OVP2} to reduce loading effect.

Current Limit Protection

The RT8510 can limit the peak current to achieve over current protection. The RT8510 senses the inductor current during the “ON” period that flows through the LX pin. The duty cycle depends on the current signal and internal slope compensation in comparison with the error signal. The internal switch will be turned off when the current signal is larger than the internal slope compensation. In the “OFF” period, the inductor current will be decreased until the internal switch is turned on by the oscillator.

Brightness Control

The RT8510 brightness dimming control is determined by the signal on the PWM pin with a suggested PWM frequency range from 120Hz to 30kHz. However, the LED current cannot be 100% proportional to duty cycle especially for high frequency and low duty ratio because of physical limitation caused by inductor rising time. Please refer to Table 1 and Figure 7.

Table 1.

Dimming Frequency (Hz)	Duty (Min.)	Duty (Max.)
120 < f _{PWM} ≤ 500	0.2%	100%
500 < f _{PWM} ≤ 1k	0.4%	100%
1k < f _{PWM} ≤ 2k	0.8%	100%
2k < f _{PWM} ≤ 5k	1.5%	100%
5k < f _{PWM} ≤ 10k	3%	100%
10k < f _{PWM} ≤ 30k	10%	100%

Note : The minimum duty in Table 1 is based on the application circuit and does not consider the deviation of current linearity.

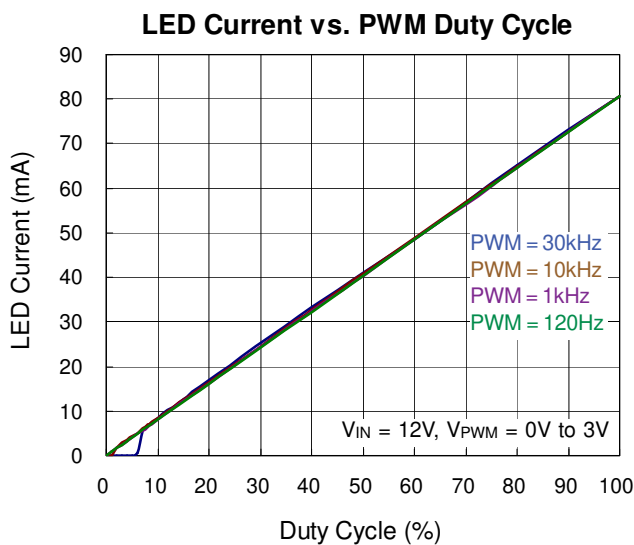

Figure 7

Over Temperature Protection

The RT8510 has over temperature protection function to prevent the IC from overheating due to excessive power dissipation. The OTP function will shutdown the IC when junction temperature exceeds 160°C .

Inductor Selection

The value of the inductance L can be approximated by the following equation, where the transition is from discontinuous conduction mode (DCM) to continuous conduction mode (CCM) :

$$L = \frac{D \times (1 - D)^2 \times V_{OUT}}{2 \times f_{OSC} \times I_{OUT}}$$

The duty cycle can be calculated according to the following equation :

$$D = \frac{V_{OUT} - V_{IN}}{V_{OUT}}$$

where V_{OUT} is the maximum output voltage, V_{IN} is the minimum input voltage, f_{OSC} is the operating frequency and I_{OUT} is the total current from all LED strings.

The boost converter operates in DCM over the entire input voltage range when the inductor value is below this value L. When inductance greater is than L, the converter operates in CCM at the minimum input voltage and may be discontinuous at higher voltages.

The inductor must be selected with a saturated current rating that is greater than the peak current provided by the following equation :

$$I_{PEAK} = \frac{V_{OUT} \times I_{OUT}}{\eta \times V_{IN}} + \frac{V_{IN} \times D \times T}{2 \times L}$$

where η is the efficiency of the power converter and T is the operating period.

Diode Selection

Schottky diodes are recommended for most applications because of their fast recovery time and low forward voltage. The power dissipation, reverse voltage rating and pulsating peak current are the important parameters for Schottky diode selection. Make sure that the diode's peak current rating exceeds I_{PEAK} and reverse voltage rating exceeds the maximum output voltage.

Output Capacitor Selection

The input capacitor reduces current spikes from the input supply and minimizes noise injection to the converter. For most applications, a 10μF ceramic capacitor is sufficient. A value higher or lower may be used depending on the noise level from the input supply and the input current to the converter.

For lower output voltage ripple, a low ESR ceramic capacitor is recommended. The output voltage ripple consists of two components: one is the pulsating output ripple current flowing through the ESR, and the other is

$$V_{RIPPLE} = V_{RIPPLE_ESR} + V_{RIPPLE_C}$$

$$\cong I_{PEAK} \times R_{ESR} + \frac{I_{PEAK}}{C_{OUT1}} \left(\frac{V_{AVDD} - V_{IN1}}{V_{AVDD} \times f \times \eta} \right)$$

Thermal Considerations

The junction temperature should never exceed the absolute maximum junction temperature $T_{J(MAX)}$, listed under Absolute Maximum Ratings, to avoid permanent damage to the device. The maximum allowable power dissipation depends on the thermal resistance of the IC package, the PCB layout, the rate of surrounding airflow, and the difference between the junction and ambient temperatures. The maximum power dissipation can be calculated using the following formula :

$$P_{D(MAX)} = (T_{J(MAX)} - T_A) / \theta_{JA}$$

where $T_{J(MAX)}$ is the maximum junction temperature, T_A is the ambient temperature, and θ_{JA} is the junction-to-ambient thermal resistance.

For continuous operation, the maximum operating junction temperature indicated under Recommended Operating Conditions is 125°C. The junction-to-ambient thermal resistance, θ_{JA} , is highly package dependent. For a WQFN-16L 3x3, the thermal resistance, θ_{JA} , is 68°C/W on a standard JEDEC 51-7 high effective-thermal-conductivity four-layer test board. The maximum power dissipation at $T_A = 25^\circ\text{C}$ can be calculated as below :

$$P_{D(MAX)} = (125^\circ\text{C} - 25^\circ\text{C}) / (68^\circ\text{C/W}) = 1.471\text{W for a WQFN-16L 3x3 package.}$$

The maximum power dissipation depends on the operating ambient temperature for the fixed $T_{J(MAX)}$ and the thermal resistance, θ_{JA} . The derating curves in Figure 1 allows the designer to see the effect of rising ambient temperature on the maximum power dissipation.

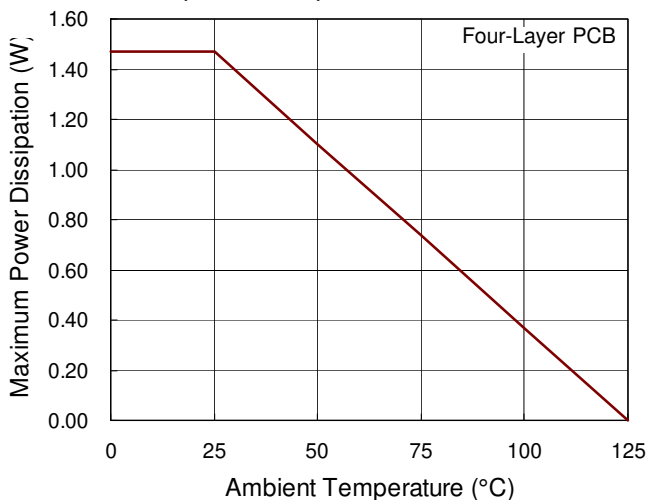

Figure 8. Derating Curve of Maximum Power Dissipation

Layout Considerations

PCB layout is very important for designing switching power converter circuits. The following layout guides should be strictly followed for best performance of the RT8510.

- ▶ The power components, L1, D1, C_{IN}, C_{OUT} must be placed as close as possible to reduce current loop. The PCB trace between power components must be as short and wide as possible.
- ▶ Place L1 and D1 as close as possible to LX pin . The trace should be as short and wide as possible.
- ▶ The compensation circuit should be kept away from the power loops and should be shielded with a ground trace to prevent any noise coupling. Place the compensation components as close as possible to COMP pin.
- ▶ The exposed pad of the chip should be connected to ground plane for thermal consideration.

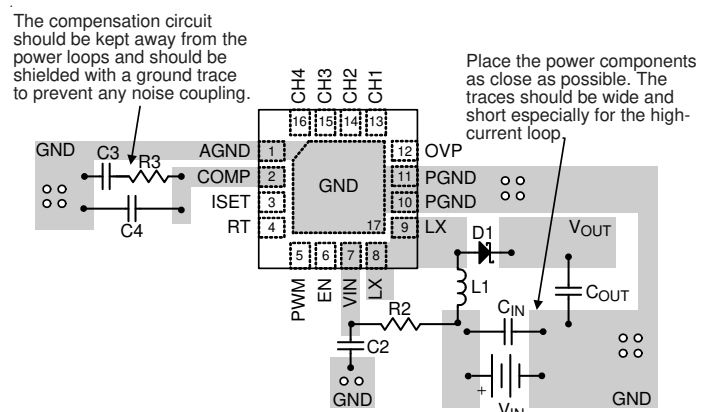
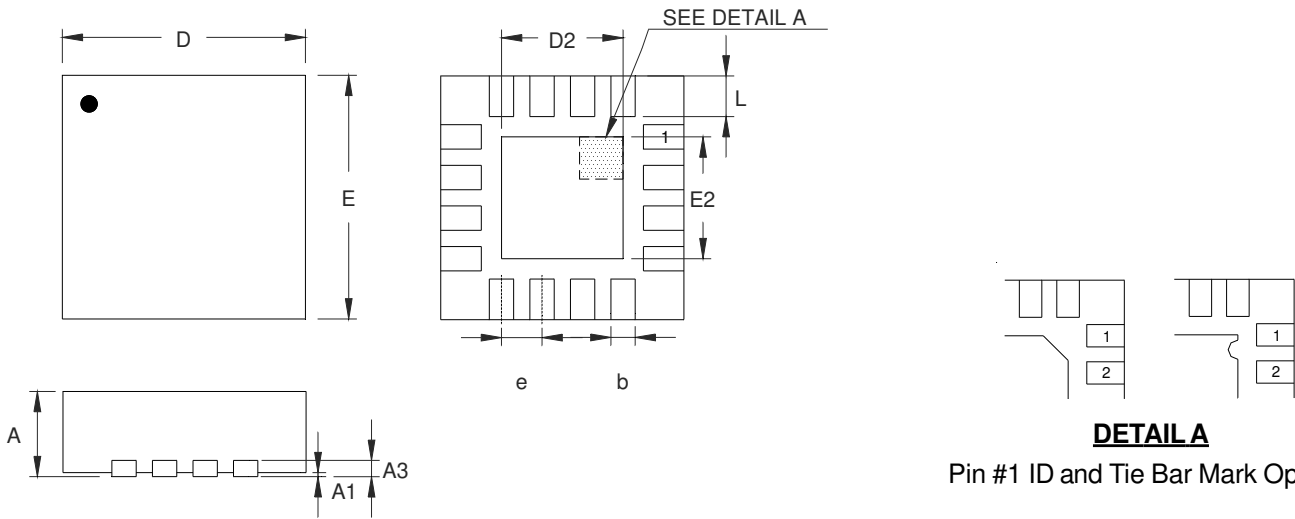

Figure 9. PCB Layout Guide

Outline Dimension



DETAIL A

Pin #1 ID and Tie Bar Mark Options

Note : The configuration of the Pin #1 identifier is optional, but must be located within the zone indicated.

Symbol	Dimensions In Millimeters		Dimensions In Inches	
	Min	Max	Min	Max
A	0.700	0.800	0.028	0.031
A1	0.000	0.050	0.000	0.002
A3	0.175	0.250	0.007	0.010
b	0.180	0.300	0.007	0.012
D	2.950	3.050	0.116	0.120
D2	1.300	1.750	0.051	0.069
E	2.950	3.050	0.116	0.120
E2	1.300	1.750	0.051	0.069
e	0.500		0.020	
L	0.350	0.450	0.014	0.018

W-Type 16L QFN 3x3 Package

Richtek Technology Corporation

14F, No. 8, Tai Yuen 1st Street, Chupei City
 Hsinchu, Taiwan, R.O.C.
 Tel: (8863)5526789

Richtek products are sold by description only. Richtek reserves the right to change the circuitry and/or specifications without notice at any time. Customers should obtain the latest relevant information and data sheets before placing orders and should verify that such information is current and complete. Richtek cannot assume responsibility for use of any circuitry other than circuitry entirely embodied in a Richtek product. Information furnished by Richtek is believed to be accurate and reliable. However, no responsibility is assumed by Richtek or its subsidiaries for its use; nor for any infringements of patents or other rights of third parties which may result from its use. No license is granted by implication or otherwise under any patent or patent rights of Richtek or its subsidiaries.