

Description

The [XR33193](#), [XR33194](#), and [XR33195](#) are a high performance RS-485/RS-422 driver family offered in a tiny TSOT23 package designed to meet the increasing system requirements found in today's performance serial communication applications. These standalone drivers operate off a single 3.3V supply and meet RS-485 and RS-422 standards for balanced RS-485 and RS-422 serial communications networks.

The driver family offers several speed options to maximize performance in different applications. The XR33193 and XR33194 have slew limited outputs for reduced EMI and for error free communication over long or improper/unterminated data cables or multi-drop applications with unterminated stubs. The XR33195 driver operates at data rates up to 20Mbps with tight skew and prop delay spec's required by demanding high speed applications. All parts in the XR33193/94/95 driver family operate over the extended temperature range of -40°C to 125°C .

The XR33193/94/95 driver family is protected by short-circuit detection as well as thermal shutdown and will maintain a high impedance state in shutdown or when powered off. The driver family also includes hot swap circuitry to protect against false transitions on the bus during power-up or live insertion.

For companion standalone RS-485/RS-422 receivers in tiny TSOT23 packages see our XR33180/81/83/84 product datasheet.

FEATURES

- Data rate options of 250kbps, 2.5Mbps and 20Mbps
- Tiny 6-pin TSOT23 package
- 3.3V $\pm 5\%$ supply operation
- Robust ESD protection
 - $\pm 15\text{kV}$ Human Body Model (bus pins)
 - $\pm 4\text{kV}$ Human Body Model (all other pins)
- Short-circuit protection
- Thermal protection circuitry
- Hot swap glitch protection
- Extended -40°C to 125°C operating temperature range
- Low current shutdown mode (2 μA max)
- Lead-free (RoHS compliant)

APPLICATIONS

- Clock distribution
- Robotic control
- Space constrained systems
- Security camera networks
- Industrial and process control equipment

Ordering Information – [back page](#)

Typical Application

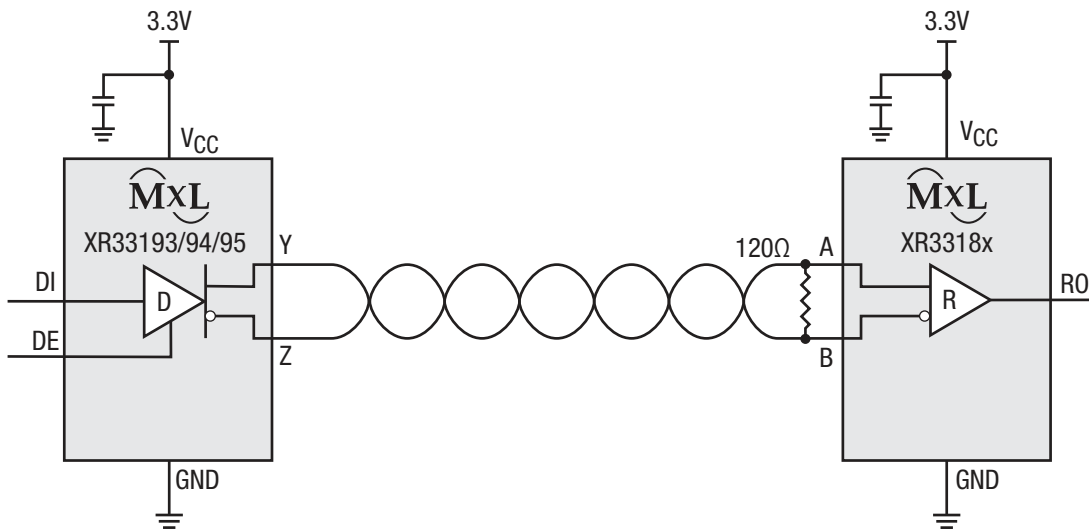

Figure 1. Typical Application

Absolute Maximum Ratings

Stresses beyond the limits listed below may cause permanent damage to the device. Exposure to any Absolute Maximum Rating condition for extended periods may affect device reliability and lifetime.

Supply voltage (V_{CC}) -0.3V to 7.0V
 Maximum junction temperature 150°C
 Input voltages, DI and DE..... -0.3V to 7.0V
 Bus output voltages Y and Z ±18V
 Transient voltage pulse through 100Ω, Figure 7 ±100V

Operating Conditions

Operating temperature range -40°C to 125°C
 V_{CC} supply range 3.135V to 3.465V
 Storage temperature range -65°C to 150°C
 Lead temperature (soldering, 10s) 300°C

Thermal Information

6-pin TSOT23 θ_{JA} 167.3°C/W
 6-pin TSOT23 θ_{JC} 61.6°C/W

ESD Ratings

HBM - Human Body Model (Y and Z pins) ±15kV
 HBM - Human Body Model (all other pins) ±4kV

Electrical Characteristics

Specifications are at $T_A = 25^\circ\text{C}$, $V_{CC} = 3.3\text{V} \pm 5\%$ unless otherwise noted. Typical values represent the most likely parametric norm at $T_A = 25^\circ\text{C}$, and are provided for reference purposes only.

Symbol	Parameter	Conditions	Min	Typ	Max	Units
Supply						
V_{CC}	Supply voltage range		3.135		3.465	V
I_{CC}	Supply current	No load (DE = V_{CC} , DI = 0V)		0.18	0.375	mA
I_{SNDN}	Supply current in shutdown mode	No load (DE = 0V)		0.5	2	μA
Logic Inputs/Outputs						
V_{IH}	Logic high input thresholds	DI and DE	2			V
V_{IL}	Logic high input thresholds	DI and DE			0.8	V
I_{IN}	Input current	DI and DE	-2		2	μA
Driver DC Characteristics						
V_{OD}	Differential driver voltage	No load	3			V
		$R_L = 100\Omega$ (RS-422), Figure 4	2			V
		$R_L = 54\Omega$ (RS-485), Figure 4	1.5			V
		$-7\text{V} \leq V_{CM} \leq 12\text{V}$, Figure 5	1.5			V
ΔV_{OD}	Change in magnitude of differential driver output voltage	$R_L = 54\Omega$ (RS-485) or 100Ω (RS-422), DE = V_{CC} , Figure 4			±0.2	V
V_{CM}	Driver common-mode output voltage (steady state)	$R_L = 54\Omega$ (RS-485) or 100Ω (RS-422), DE = V_{CC} , DI = V_{CC} or GND, Figure 4	-1	$V_{CC}/2$	3	V
ΔV_{CM}	Change in magnitude of driver common-mode output voltage	$R_L = 54\Omega$ (RS-485) or 100Ω (RS-422)			0.2	V
V_{OL}	Output leakage	Y and Z, $V_{OUT} = 12\text{V}$, DE = 0V, $V_{CC} = 3.3\text{V}$ or GND	-20		20	μA
		Y and Z, $V_{OUT} = -7\text{V}$, DE = 0V, $V_{CC} = 3.3\text{V}$ or GND	-20		20	μA
I_{OSD}	Driver short-circuit output current	$-7\text{V} \leq V_{OUT} \leq 12\text{V}$, Figure 6			±250	mA

Electrical Characteristics (Continued)

Specifications are at $T_A = 25^\circ\text{C}$, $V_{CC} = 3.3\text{V} \pm 5\%$ unless otherwise noted. Typical values represent the most likely parametric norm at $T_A = 25^\circ\text{C}$, and are provided for reference purposes only.

Symbol	Parameter	Conditions	Min	Typ	Max	Units
Thermal Characteristics						
T_{TS}	Thermal shutdown temperature			165		$^\circ\text{C}$
T_{TSH}	Thermal shutdown hysteresis			40		$^\circ\text{C}$
Driver AC Characteristics XR33193 (250kbps)						
t_{DPLH}	Driver propagation delay (low to high)	$C_L = 50\text{pF}$, $R_L = 54\Omega$, Figure 8	400		1300	ns
t_{DPHL}	Driver propagation delay (high to low)		400		1300	ns
t_{SKEW}	Driver propagation delay skew, $ t_{DPLH} - t_{DPHL} $				400	ns
t_R , t_F	Differential output rise or fall time	$C_L = 50\text{pF}$, $R_L = 54\Omega$, Figure 8	400		1200	ns
	Device to device propagation delay matching ⁽¹⁾	Same power supply, maximum temperature difference between devices = 30°C			900	ns
	Maximum data rate	$C_L = 50\text{pF}$, $R_L = 54\Omega$, duty cycle 40 to 60%	250			kbps
t_{DZH}	Driver enable to output high	$C_L = 100\text{pF}$, $R_L = 500\Omega$, Figure 9			2000	ns
t_{DZL}	Driver enable to output low				2000	ns
t_{DHZ}	Driver disable from output high				1000	ns
t_{DLZ}	Driver disable from output low				1000	ns
Driver AC Characteristics XR33194 (2.5Mbps)						
t_{DPLH}	Driver propagation delay (low to high)	$C_L = 50\text{pF}$, $R_L = 54\Omega$, Figure 8	24		70	ns
t_{DPHL}	Driver propagation delay (high to low)		24		70	ns
t_{SKEW}	Driver propagation delay skew, $ t_{DPLH} - t_{DPHL} $				40	ns
t_R , t_F	Differential output rise or fall time	$C_L = 50\text{pF}$, $R_L = 54\Omega$, Figure 8	10		70	ns
	Device to device propagation delay matching ⁽¹⁾	Same power supply, maximum temperature difference between devices = 30°C			46	ns
	Maximum data rate	$C_L = 50\text{pF}$, $R_L = 54\Omega$, duty cycle 40 to 60%	2.5			Mbps
t_{DZH}	Driver enable to output high	$C_L = 100\text{pF}$, $R_L = 500\Omega$, Figure 9			400	ns
t_{DZL}	Driver enable to output low				400	ns
t_{DHZ}	Driver disable from output high				100	ns
t_{DLZ}	Driver disable from output low				100	ns

NOTE:

1. Guaranteed by design; not production tested.

Electrical Characteristics (Continued)

Specifications are at $T_A = 25^\circ\text{C}$, $V_{CC} = 3.3\text{V} \pm 5\%$ unless otherwise noted. Typical values represent the most likely parametric norm at $T_A = 25^\circ\text{C}$, and are provided for reference purposes only.

Symbol	Parameter	Conditions	Min	Typ	Max	Units
Driver AC Characteristics XR33195 (20Mbps)						
t_{DPLH}	Driver propagation delay (low to high)	$C_L = 15\text{pF}$, $R_L = 54\Omega$, Figure 8			25	ns
t_{DPHL}	Driver propagation delay (high to low)				25	ns
t_{SKEW}	Driver propagation delay skew, $ t_{DPLH} - t_{DPHL} $			5		ns
t_R , t_F	Differential output rise or fall time	$T_A = -40^\circ\text{C}$ to 125°C , $C_L = 50\text{pF}$, $R_L = 54\Omega$, Figure 8			18.5	ns
		$T_A \leq 85^\circ\text{C}$, $C_L = 50\text{pF}$, $R_L = 54\Omega$, Figure 8			15	ns
	Device to device propagation delay matching ⁽¹⁾	Same power supply, maximum temperature difference between devices = 30°C			25	ns
	Maximum data rate	$T_A \leq 85^\circ\text{C}$, $C_L = 50\text{pF}$, $R_L = 54\Omega$, duty cycle 40 to 60%	20			Mbps
	Maximum data rate	$C_L = 50\text{pF}$, $R_L = 54\Omega$, duty cycle 40 to 60%	16			Mbps
t_{DZH}	Driver enable to output high	$C_L = 100\text{pF}$, $R_L = 500\Omega$, Figure 9			400	ns
t_{DZL}	Driver enable to output low				400	ns
t_{DHZ}	Driver disable from output high				100	ns
t_{DLZ}	Driver disable from output low				100	ns

NOTE:

1. Guaranteed by design; not production tested.

Pin Configuration

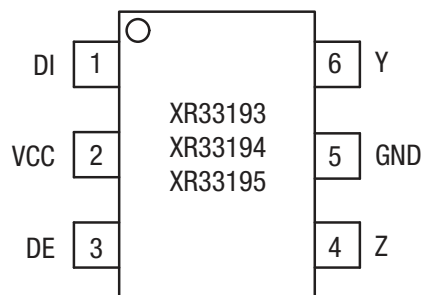

TSOT23-6, Top View

Pin Functions

Pin Number			Pin Name	Type	Description
XR33193	XR33194	XR33195			
1	1	1	DI	Input	Driver input. A low on DI forces the Y output low and the Z output high. A high on DI forces the Y output high and the Z output low.
2	2	2	VCC	Supply	Power supply ($V_{CC} = 3.3V \pm 5\%$). Bypass with $0.1\mu F$ capacitor to ground.
3	3	3	DE	Input	Driver output enable. A high on DE enables the driver outputs (Y and Z). A low on DE will disable the driver outputs (Y and Z), tri-stating the outputs and putting the device into shutdown (low power) state. The hot swap function is implemented on the DE pin, see Applications Information section for a description of hot swap function.
4	4	4	Z	Bus Output	$\pm 15kV$ ESD protected, RS-485/RS-422 inverting driver output.
5	5	5	GND	Supply	Ground.
6	6	6	Y	Supply	$\pm 15kV$ ESD protected, RS-485/RS-422 non-inverting driver output.

Functional Block Diagram

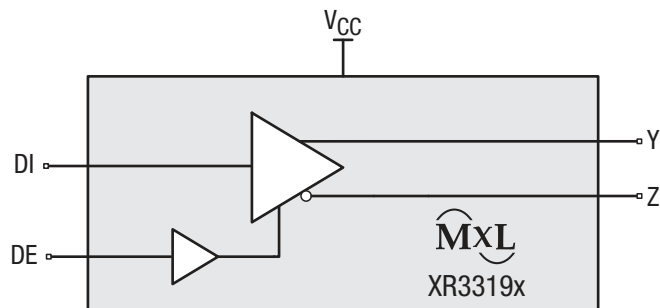

Figure 2. Functional Block Diagram

Applications Information

The XR3319x RS-485/RS-422 devices are part of MaxLinear's high performance serial interface product line. These standalone drivers operate off a single 3.3V supply and meet RS-485 and RS-422 standards for balanced RS-485 and RS-422 serial communications networks.

Hot Swap Capability

When V_{CC} is first applied the XR3319x family holds the driver enable inactive for approximately 10 μ s. During power ramp-up, other system ICs may drive unpredictable values or tristated lines may be influenced by stray capacitance. The hot swap feature prevents the XR3319x family from driving any output signal until power has stabilized. After the initial 10 μ s, the driver enable pin is weakly pulled to the disabled state (low for DE) until the first transition. After the first transition, the DE pin operate as high impedance input.

If circuit boards are inserted into an energized backplane (commonly called "live insertion" or "hot swap") power may suddenly be applied to all circuits. Without the hot swap capability, this situation could improperly enable the transceiver's driver, driving invalid data onto shared buses and possibly causing driver contention or device damage.

Driver Output Protection

Two mechanisms prevent excessive output current and power dissipation caused by faults or by bus contention. First, a driver current limit on the output stage provides immediate protection against short circuits over the whole common-mode voltage range. Second, a thermal shutdown circuit forces the driver outputs into a high impedance state if junction temperature becomes excessive.

Line Length

The RS-485/RS-422 standard covers line lengths up to 4000ft. Maximum achievable line length is a function of signal attenuation and noise. Termination prevents signal reflections by eliminating the impedance mismatches on a transmission line. Line termination is generally used if rise and fall times are shorter than the round trip signal propagation time. Higher output drivers may allow longer cables to be used.

± 15 kV HBM ESD Protection (Unpowered Part)

ESD protection structures are incorporated on all pins to protect against electrostatic discharges encountered during handling and assembly. The driver outputs of the XR3319x family have extra protection against static electricity. MaxLinear uses state-of-the-art structures to protect these pins against ESD damage:

- ± 15 kV HBM for bus pins to GND
- ± 4 kV HBM for all other pins

ESD Test Conditions

ESD performance depends on a variety of conditions. Contact MaxLinear for a reliability report that documents test setup, methodology and results.

Low Power Shutdown Mode

The XR3319x has a low-power shutdown mode that is initiated by bringing DE low (to disable the XR33193/94/95). While in shutdown the XR3319x draws less than 2 μ A of supply current.

Applications Information (Continued)

Product Selector Guide

Part Number	Data Rate (Mbps)	Slew-Rate Limited	Package
XR33193	0.25	Yes	6-pin TSOT23
XR33194	2.5	Yes	
XR33195	20	No	

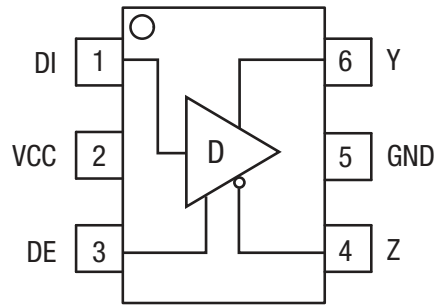

Figure 3. Differential Driver

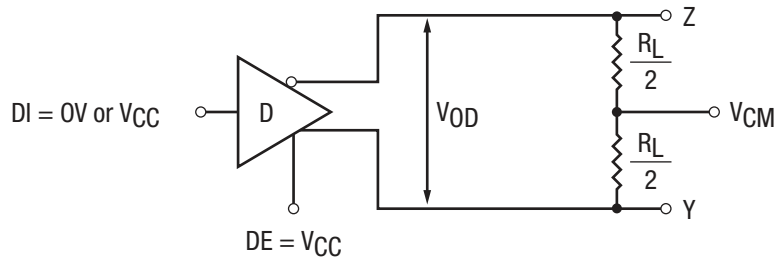

Figure 4. Differential Driver Output Voltage

Applications Information (Continued)

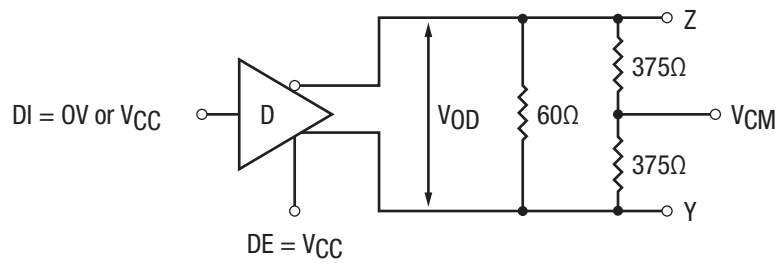

Figure 5. Differential Driver Output Voltage Over Common Mode

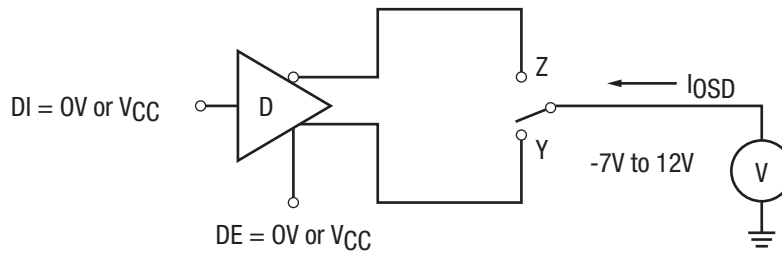

Figure 6. Driver Output Short-Circuit Current

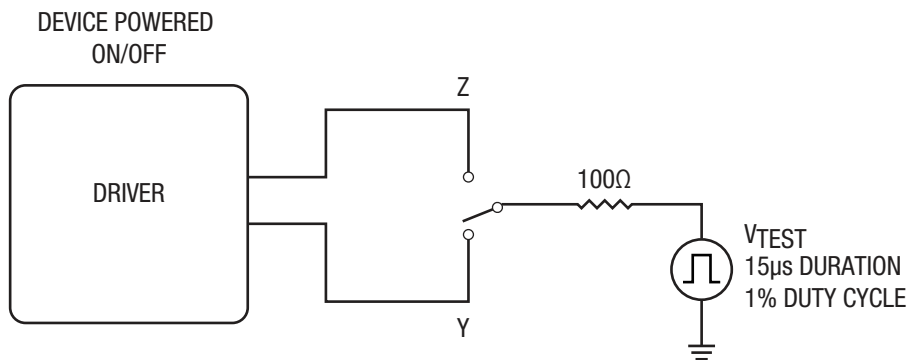

Figure 7. Transient Overvoltage Test Circuit

Applications Information (Continued)

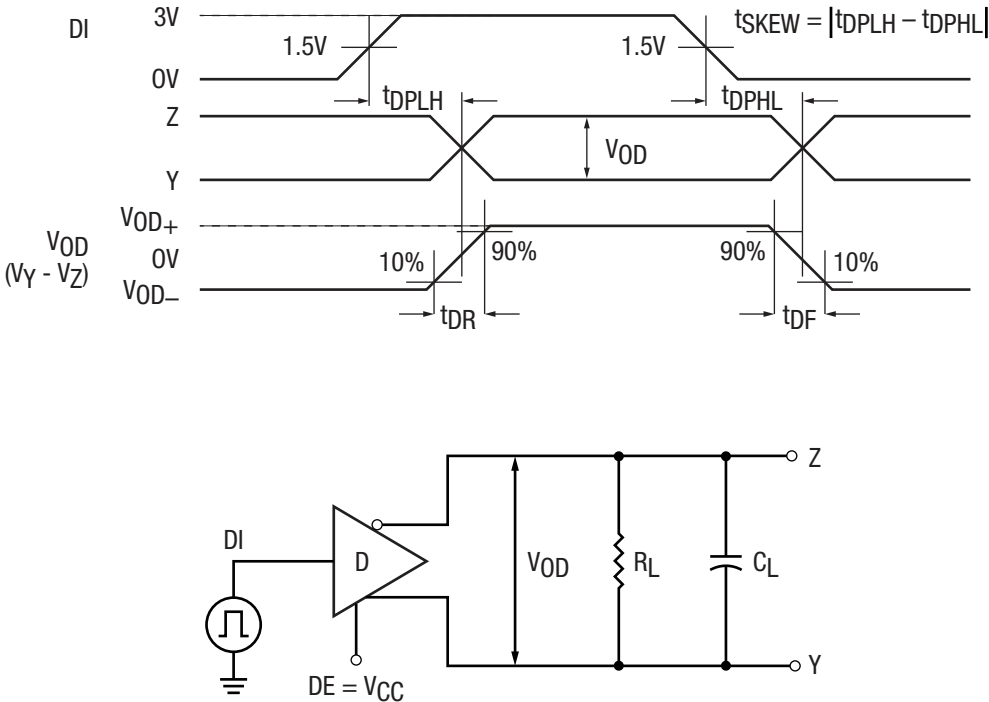

Figure 8. Driver Propagation Delay Test Circuit and Timing Diagram

Applications Information (Continued)

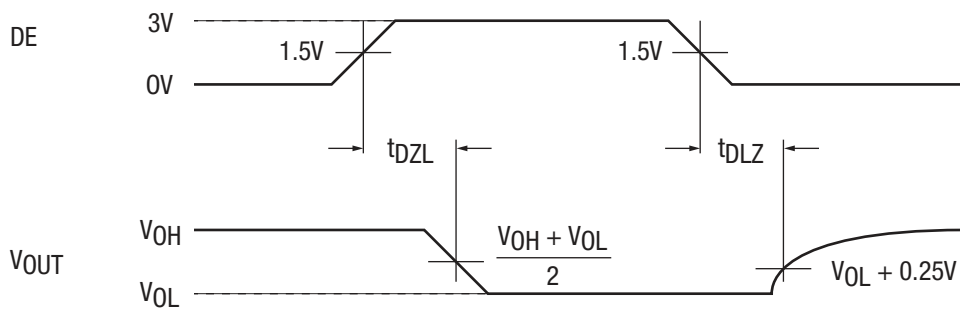
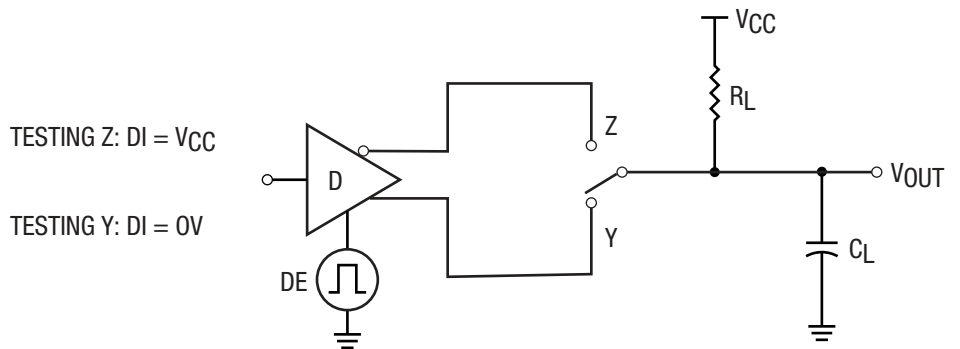
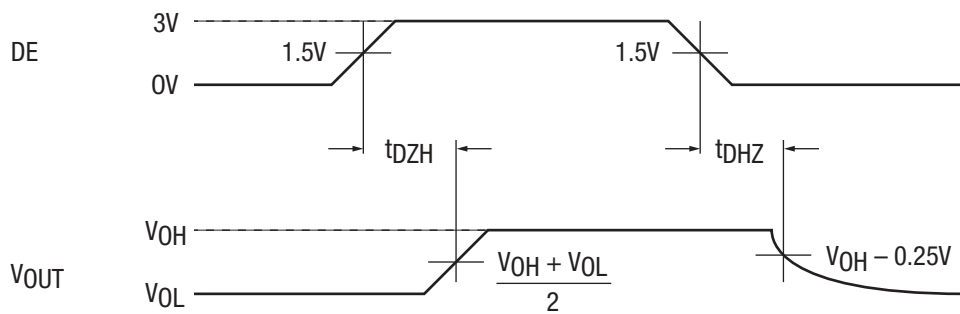
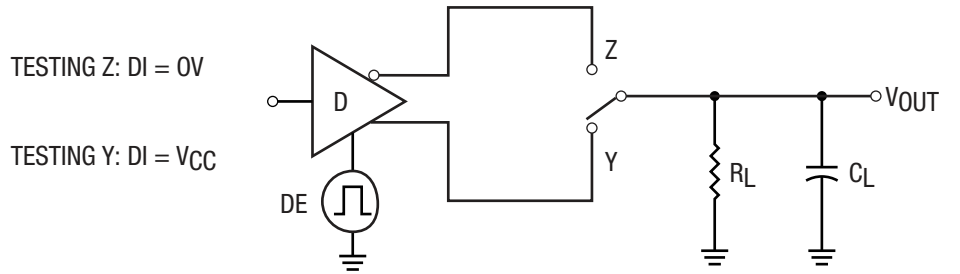
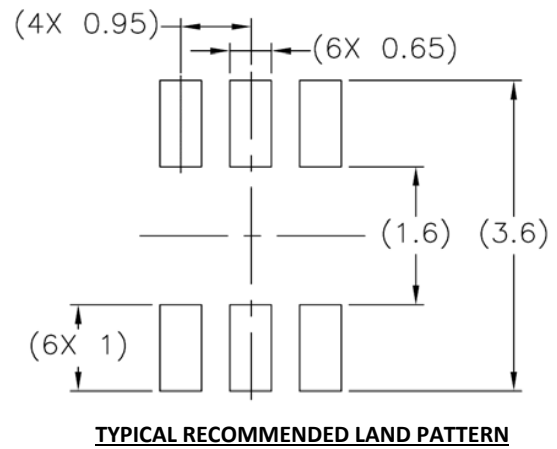
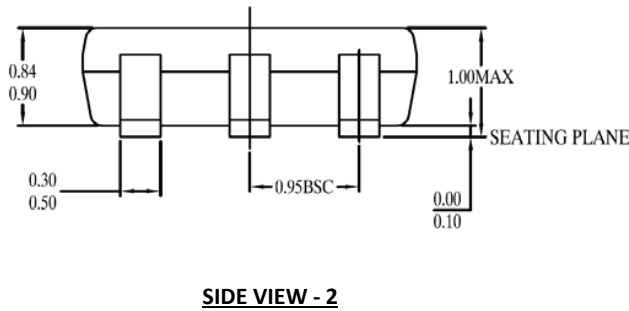
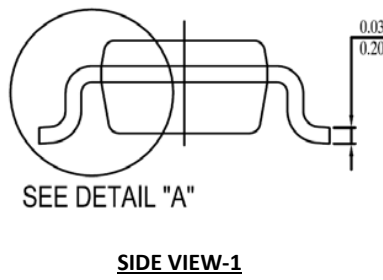
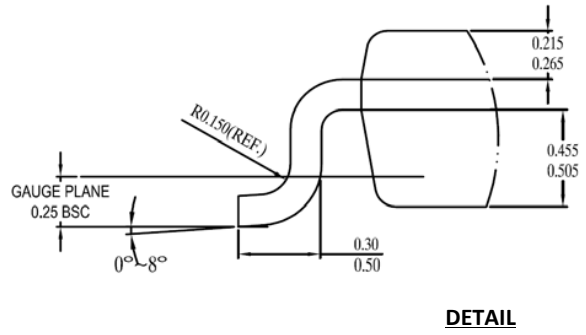
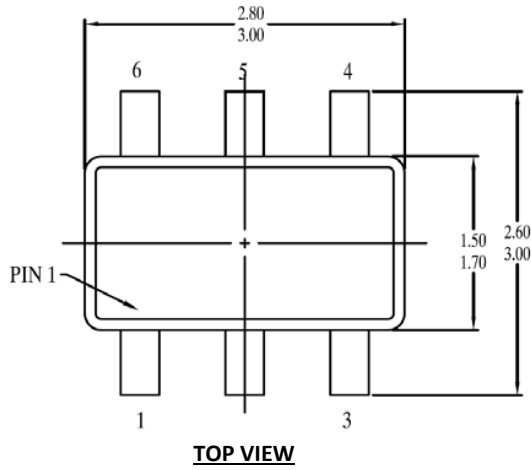

Figure 9. Driver Enable and Disable Timing Test Circuits and Timing Diagrams

Mechanical Dimensions

TSOT23-6



1. All dimensions are in Millimeters
2. Dimensions and tolerance per Jecdec MO-193

Drawing No. : POD - 00000077

Revision: A.1

Ordering Information⁽¹⁾

Part Number	Speed (Mbps)	Slew Rate Limited	Operating Temperature Range	Lead-Free	Package	Packaging Method
XR33193ESBTR	0.250	Yes	-40°C to 125°C	Yes ⁽²⁾	6-pin TSOT23	Tape and Reel
XR33194ESBTR	2.50	Yes				
XR33195ESBTR	20	No				
XR33193ESBEVB	Evaluation board					
XR33194ESBEVB						
XR33195ESBEVB						

NOTE:

1. Refer to www.exar.com/XR33193, www.exar.com/XR33194, www.exar.com/XR33195 for most up-to-date Ordering Information.
2. Visit www.exar.com for additional information on Environmental Rating.

Revision History

Revision	Date	Description
1A	July 2016	Initial release.
1B	February 2018	Update to MaxLinear logo. Update format and Ordering Information format. Moved ESD ratings to page 2.



Corporate Headquarters:
 5966 La Place Court
 Suite 100
 Carlsbad, CA 92008
 Tel.: +1 (760) 692-0711
 Fax: +1 (760) 444-8598
www.maxlinear.com

High Performance Analog:
 1060 Rincon Circle
 San Jose, CA 95131
 Tel.: +1 (669) 265-6100
 Fax: +1 (669) 265-6101
 Email: serialtechsupport@exar.com
www.exar.com

The content of this document is furnished for informational use only, is subject to change without notice, and should not be construed as a commitment by MaxLinear, Inc.. MaxLinear, Inc. assumes no responsibility or liability for any errors or inaccuracies that may appear in the informational content contained in this guide. Complying with all applicable copyright laws is the responsibility of the user. Without limiting the rights under copyright, no part of this document may be reproduced into, stored in, or introduced into a retrieval system, or transmitted in any form or by any means (electronic, mechanical, photocopying, recording, or otherwise), or for any purpose, without the express written permission of MaxLinear, Inc.

MaxLinear, Inc. does not recommend the use of any of its products in life support applications where the failure or malfunction of the product can reasonably be expected to cause failure of the life support system or to significantly affect its safety or effectiveness. Products are not authorized for use in such applications unless MaxLinear, Inc. receives, in writing, assurances to its satisfaction that: (a) the risk of injury or damage has been minimized; (b) the user assumes all such risks; (c) potential liability of MaxLinear, Inc. is adequately protected under the circumstances.

MaxLinear, Inc. may have patents, patent applications, trademarks, copyrights, or other intellectual property rights covering subject matter in this document. Except as expressly provided in any written license agreement from MaxLinear, Inc., the furnishing of this document does not give you any license to these patents, trademarks, copyrights, or other intellectual property.

Company and product names may be registered trademarks or trademarks of the respective owners with which they are associated.