

Features/Benefits

- Operating life 500,000 cycles
- Low profile 4 mm and 3.2 mm height
- Card detection sealed switch

Typical Applications

- Transaction
- Identification
- POS
- MPOS



Full Size

Mechanical

| | |
|------------------------|----------------------|
| NUMBER OF CONTACTS: | 8 |
| MECHANICAL LIFE: | 500,000 cycles |
| CARD INSERTION FORCE: | 10 N max. |
| CARD EXTRACTION FORCE: | 1 N min. / 10 N max. |
| CONTACT FORCE: | 0,2 N / 0,60 N max. |

Packaging

Tray 25 parts or Reel 350 parts

Soldering

Compatible with lead free SMT reflow soldering process

Contact Electrical Data

| | |
|------------------------|---------------------------|
| INSULATION RESISTANCE: | 1,000 M Ω min. |
| CONTACT RESISTANCE: | 100 m Ω max. |
| CURRENT RATING: | 10 μ A min. / 1A max. |
| DIELECTRIC STRENGTH: | 750 Vrms min. |

Switch Electrical Data

| | |
|------------------------|------------------------|
| CARD DETECTION SWITCH: | Normally open |
| CONTACT RESISTANCE: | 100 m Ω max. |
| DIELECTRIC STRENGTH: | 250 Vrms min. |
| CURRENT RATING: | 1 mA min. / 10 mA max. |
| MAXIMUM POWER: | 0.2 VA |

Environmental Data

| | |
|------------------------|---------------------|
| OPERATING TEMPERATURE: | -40°C to + 85°C |
| CARD DETECTION SWITCH: | Sealed against dust |
| RoHS compliant | |

How To Order

To order, simply select desired option from each category and place in the appropriate box. For additional options not shown in catalog, consult our Customer Service Center.

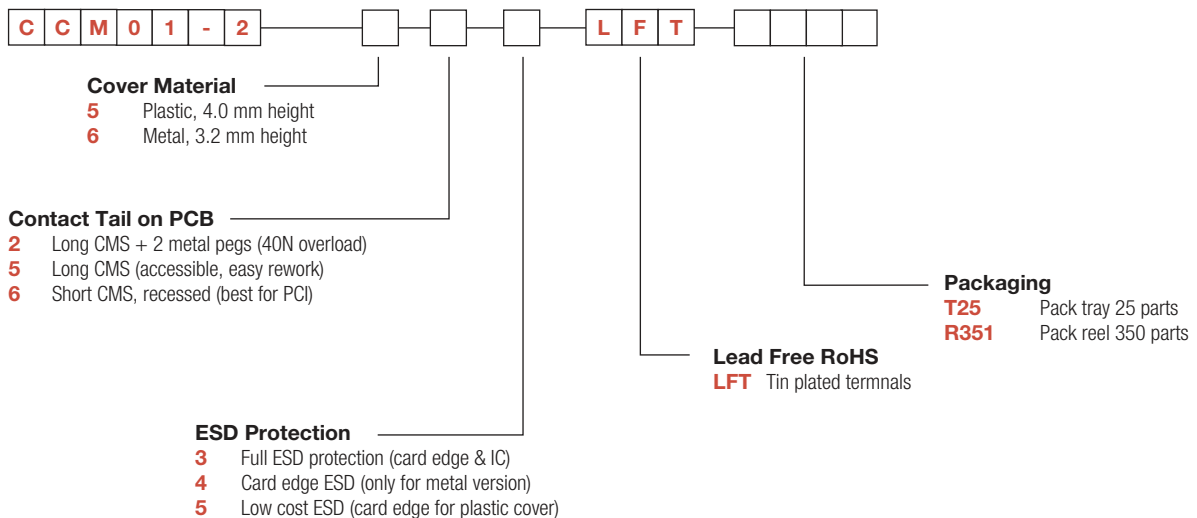

CCM01 MK5 Series

CCM01-2664 LFT T25 Metal cover, short tails

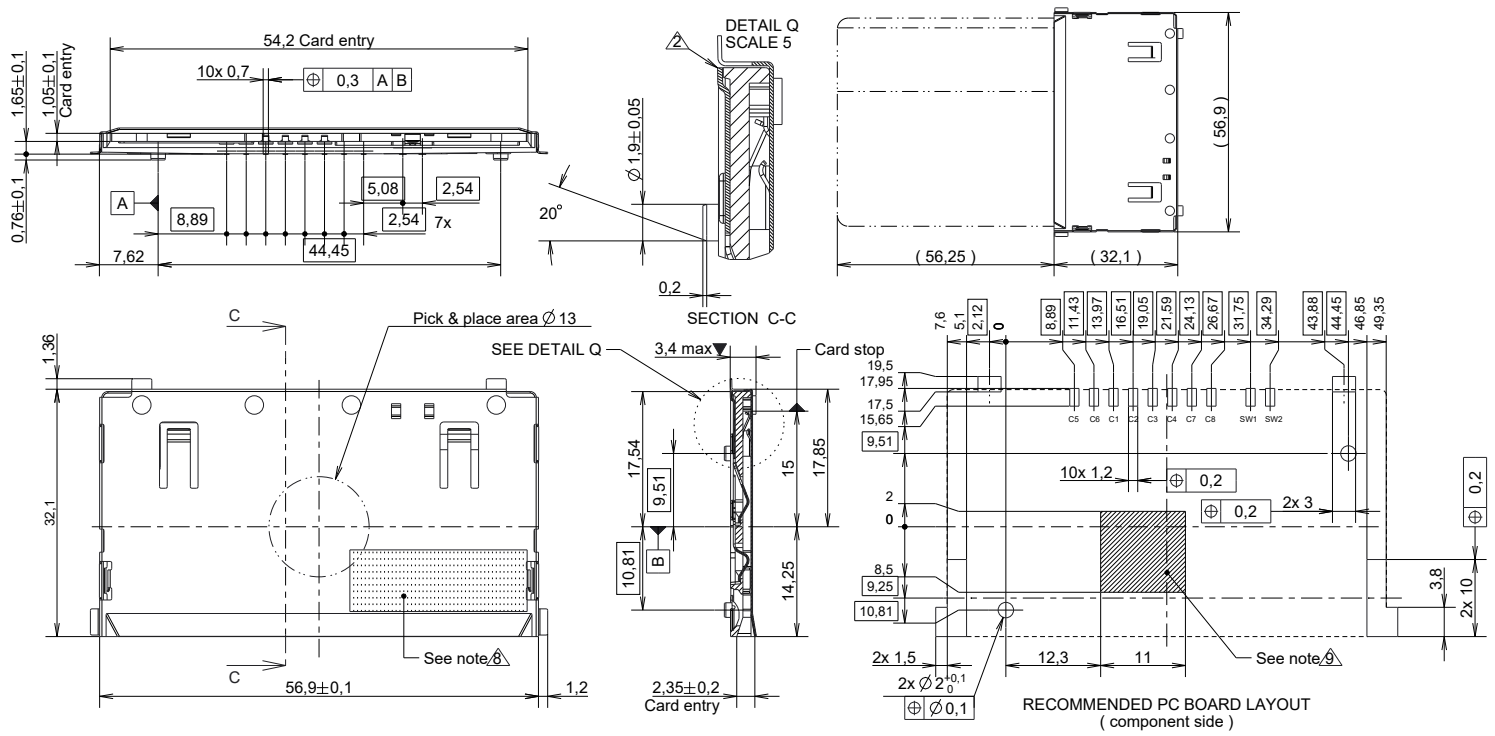

CCM01-2553 LFT T25 Plastic cover, long tails, full ESD protection

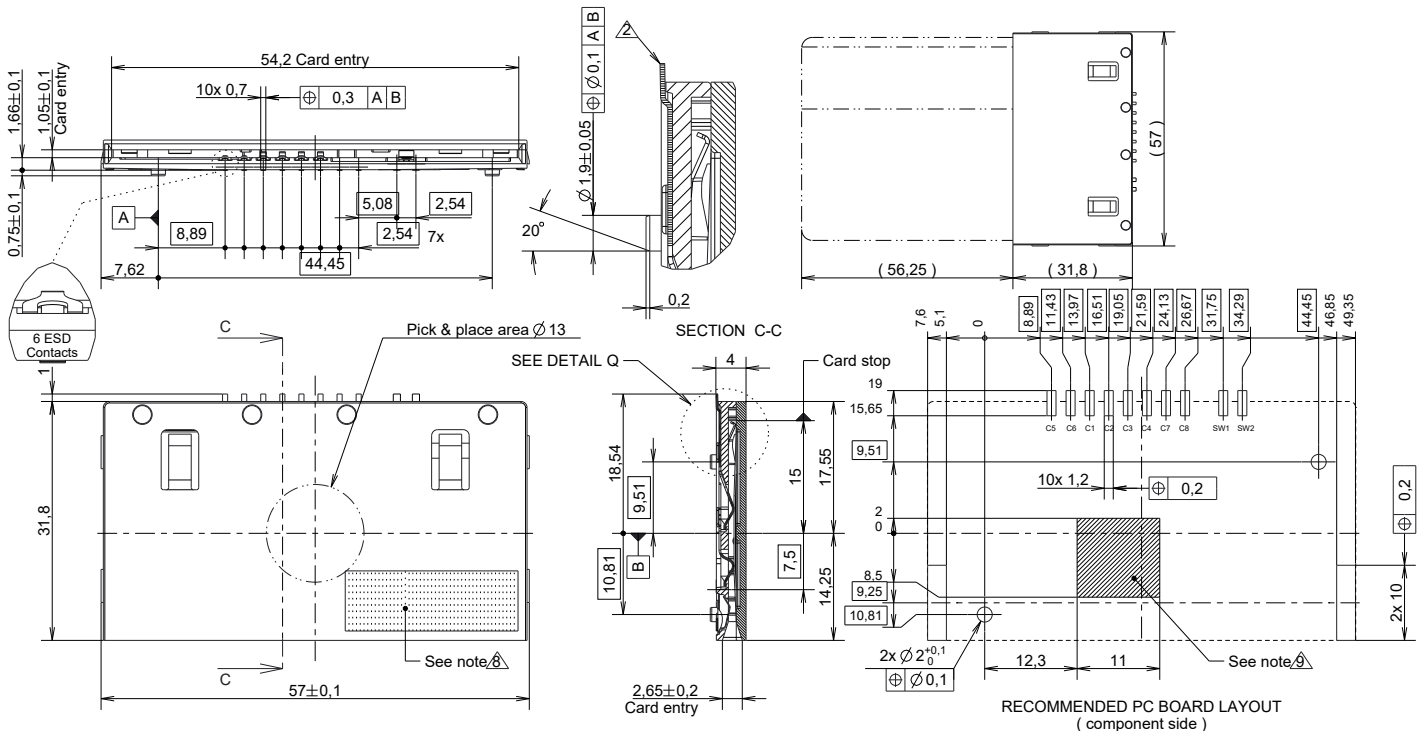

18 May 20



Dimensions are shown in mm
Specifications and dimensions subject to change

www.ckswitches.com

CCM01 MK5 Series

CCM01-2565 LFT T25 Plastic cover, long tails, metal pegs

Full Size

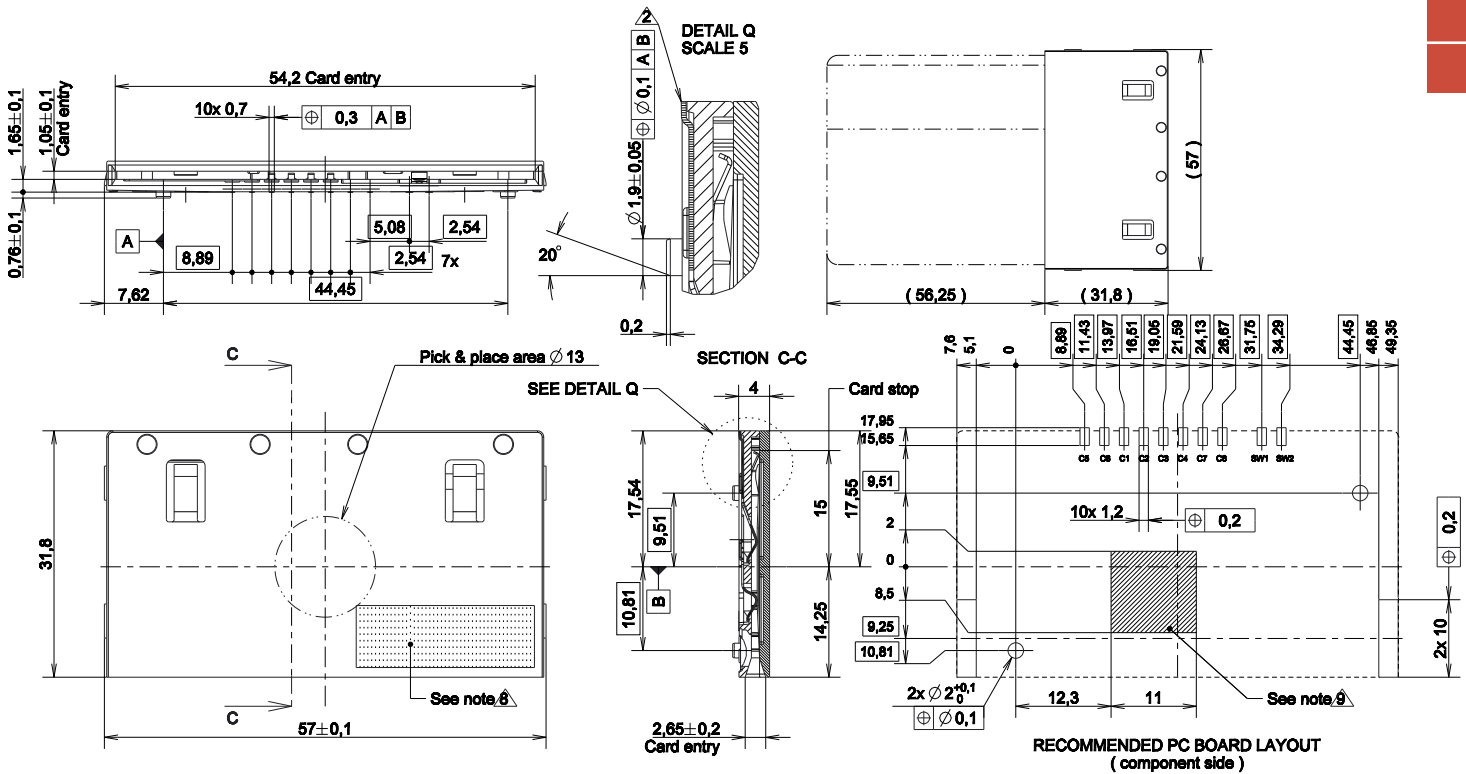

18 May 20



Dimensions are shown in mm
Specifications and dimensions subject to change

www.ckswitches.com