

没有Nuventix的书面授权，不允许替代材料或不同材料以及零件或工艺过程的更改

REV	DESCRIPTION	BY	APR	DATE
A01	PRODUCTION RELEASE	DNG		2010-10-27

SUBSTITUTIONS OR DEVIATIONS OF MATERIALS, COMPONENTS OR MANUFACTURING PROCESSES IS NOT ALLOWED WITHOUT WRITTEN CONSENT FROM NUVENTIX, INC.

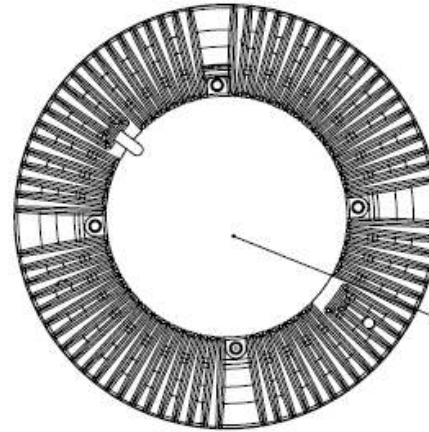
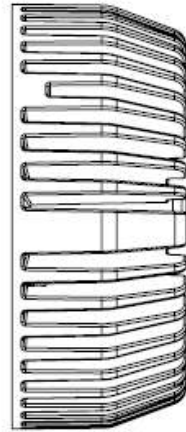
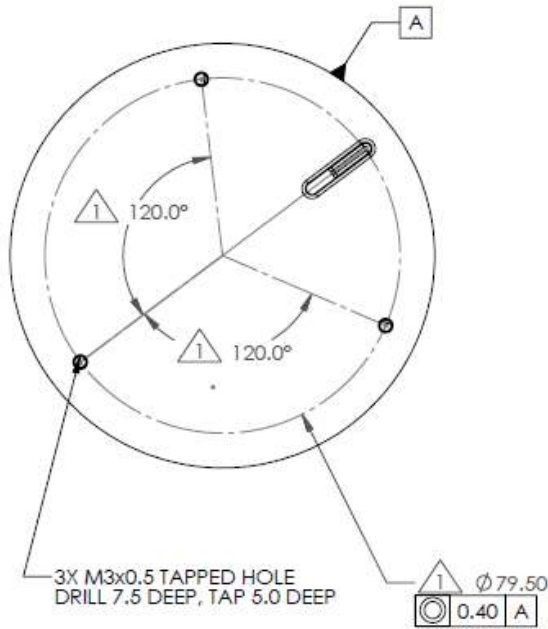

BASE PART

NOTES:

DIMENSION IS CRITICAL TO FUNCTION

2. IDENTIFY THE PART IN THE AREA SHOWN PER NUVENTIX SPECIFICATION MFG-SPEC-00023.

PART #	BASE PART	DESCRIPTION
030-00277-01	030-00195	BLACK
030-00277-02	030-00195-01	SAND BLAST FINISH, NATURAL COLOR

PROPRIETARY AND CONFIDENTIAL: THE INFORMATION CONTAINED IN THIS DRAWING IS THE SOLE PROPERTY OF NUVENTIX, INC. ANY REPRODUCTION IN PART OR AS A WHOLE WITHOUT THE WRITTEN PERMISSION OF NUVENTIX, INC IS PROHIBITED.

UNLESS OTHERWISE SPECIFIED: -ALL DIMENSIONS IN MILLIMETERS -DRAFT ANGLES TO BE 3 DEGREES -DIMENSIONS INCLUDE PLATING		NAME	DATE	
TOLERANCES: .X: ± 0.2 .XX: ± 0.1 ANGLES: ± 0.5°		DRAWN	DNG	
MATERIAL N/A		CHECKED	A	
FINISH N/A		ENG APPR.	A	TITLE: DRAWING, PAR30 HEAT SINK MACHINING, FORTIMO TWISTABLE
SIZE B	DO NOT SCALE DRAWING	THIRD ANGLE PROJECTION		DWG. NO. 031-00001
				REV A01
				SCALE: 1:1 SHEET 1 OF 1

HP30S-CALBL-002 Heat Sink, 40W, Down Light Module 95, Philips Twistable, Zhaga B2, Black