

0.14 ±0.05  
PIN WIDTH

⊕ 0.15 Y

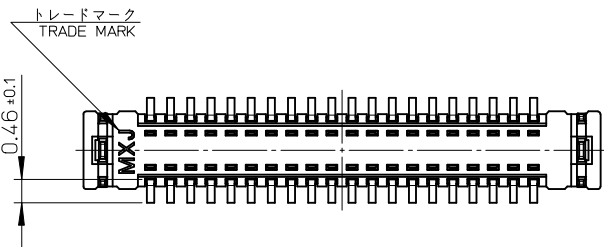
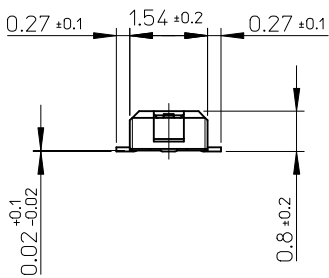
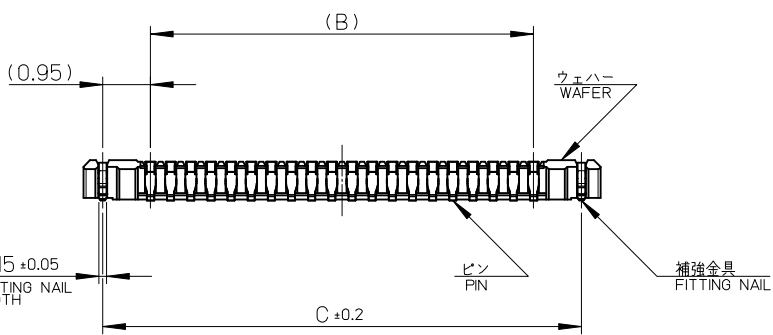

17.5	15.6	18.26	502430-8010	80
14.3	12.4	15.06	502430-6410	64
13.5	11.6	14.26	502430-6010	60
11.5	9.6	12.26	502430-5010	50
10.3	8.4	11.06	502430-4410	44
9.5	7.6	10.26	502430-4010	40
8.3	6.4	9.06	502430-3410	34
7.9	6.0	8.66	502430-3210	32
7.5	5.6	8.26	502430-3010	30
6.7	4.8	7.46	502430-2610	26
6.3	4.4	7.06	502430-2410	24
5.9	4.0	6.66	502430-2210	22
5.5	3.6	6.26	502430-2010	20
4.3	2.4	5.06	502430-1410	14
C	B	A	EMBOSSED PACKAGE オーダー番号 ORDER No.	極数 CIRCUITS

CONNECTOR SERIES No. 502430-\*\*19

REVISED EC NO: J2010-0990 DRWN: TSUZUKI 01 2009/11/09 CHKD: THIRATA 2009/11/09 APPR: MSASAO 2009/11/10	GENERAL TOLERANCES (UNLESS SPECIFIED)		DIMENSION STYLE MM ONLY		SCALE 10:1	DESIGN UNITS METRIC	THIRD ANGLE PROJECTION		
	10 UNDER ± ---	10 OVER 30 UNDER ± ---	DRAWN BY RTAKEUCHI	DATE 2007/10/03	TITLE 0.4 B-TO-B CONN. HGT=1.0 W=2.6 PLUG ASSY				
	30 OVER ± ---	ANGULAR ± --- °	CHECKED BY MSASAO	DATE 2007/10/03	MOLEX INCORPORATED				
	DRAFT WHERE APPLICABLE MUST REMAIN WITHIN DIMENSIONS		APPROVED BY MSASAO	DATE 2007/10/03	MATERIAL NO. SEE TABLE	DOCUMENT NO. SD-502430-001	SHEET NO. 1 OF 2		

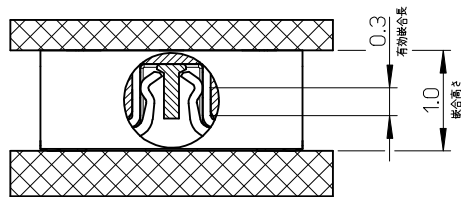

嵌合断面図 (参考)  
MATED DRAWING (REFERENCE)

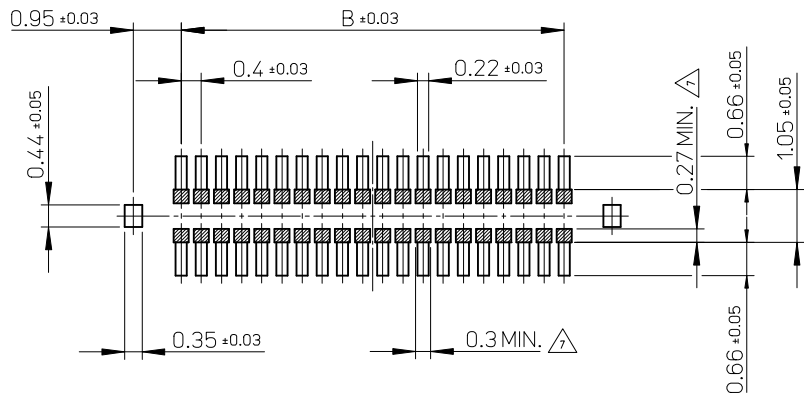

P.C. BOARD PATTERN LAYOUT  
(REFERENCE)

注記 NOTES

1. 使用材料 MATERIAL

ウェハー : 液晶ポリマー ( LCP ) ガラス充填 UL94V-0 ( 黒 )  
WAFER: LIQUID CRYSTAL POLYMER (GLASS FILLED) UL94V-0 (COLOR: BLACK)

ピン : りん青銅 (t=0.08)  
PIN : PHOSPHOR BRONZE (t=0.08)

金具 : りん青銅 (t=0.15)  
FITTING NAIL : PHOSPHOR BRONZE (t=0.15)

2. メッキ仕様 PLATING

ピン PIN

金メッキ : 0.1 マイクロメートル以上  
GOLD 0.1MICROMETER MINIMUM

下地メッキ : ニッケルメッキ 1.0 マイクロメートル以上  
UNDER PLATING : NICKEL 1.0MICROMETER MINIMUM

※コンタクト部とテール部はニッケルメッキによって分断されている金メッキです。  
DIVIDE INTO PARTS THE GOLD PLATING OF THE CONTACT AND THE TAIL PART BY THE NICKEL PLATING.

※封孔処理品

金具 FITTING NAIL

フラッシュ金メッキ  
FLASH Au PLATING

下地メッキ : ニッケルメッキ 1.0 マイクロメートル以上  
UNDER PLATING : NICKEL 1.0MICROMETER MINIMUM

△ (全極数 / 2) = 偶数の場合に適用。  
APPLY FOR (CIRCUIT/2)=EVEN.

4. 嵌合相手 : 502426 シリーズ  
MATE WITH : 502426 SERIES.

5. テール平坦度は、0.08 以下

テール及び金具の平坦度は、0.1 以下  
TAIL COPLANARITY TO BE 0.08MAXIMUM.  
TAIL AND FITTING NAIL COPLANARITY TO BE 0.1MAXIMUM.

6. ELV 及び RoHS 適合品  
ELV AND RoHS COMPLIANT.

△ 斜線部はパターン書込み禁止範囲と半田禁止範囲を示す。

ただし、斜線部に同一配線を配置する場合はレジストを施し、この部分に半田は無きこと。  
NO PATTERN CIRCUIT AND NO SOLDER ALLOWED IN THE SHADED AREA.  
HOWEVER, IF NEEDED TO ADD A TRACE OF THE SAME CIRCUIT, PUT THE SOLDER-RESIST,  
YET NO SOLDER ALLOWED IN THE AREA.

REVISED EC NO: J2010-0990 DRWN: TSUZUKI 2009/11/09 CHKD: THIRATA 2009/11/09 APPR: MSASAO 2009/11/10	GENERAL TOLERANCES (UNLESS SPECIFIED)		DIMENSION STYLE MM ONLY	SCALE 10:1	DESIGN UNITS METRIC	THIRD ANGLE PROJECTION
	10 UNDER	± ---	DRAWN BY RTAKEUCHI	DATE 2007/10/03	TITLE 0.4 B-TO-B CONN. HGT=1.0 W=2.6 PLUG ASSY	
	10 OVER 30 UNDER	± ---	CHECKED BY MSASAO	DATE 2007/10/03	MOLEX INCORPORATED	
	30 OVER	± ---	APPROVED BY MSASAO	DATE 2007/10/03	DOCUMENT NO. SD-502430-001	SHEET NO. 2 OF 2
REV	DESCRIPTION	ANGULAR ± --- °	MATERIAL NO. SEE SHEET 1	THIS DRAWING CONTAINS INFORMATION THAT IS PROPRIETARY TO MOLEX INCORPORATED AND SHOULD NOT BE USED WITHOUT WRITTEN PERMISSION		
DRAFT WHERE APPLICABLE MUST REMAIN WITHIN DIMENSIONS						

注記 NOTES

- 製品詳細寸法については製品単体図面を参照下さい。  
FOR DETAIL OF CONNECTOR DIMENSIONS,  
PLEASE SEE THE DRAWING OF CONNECTOR ITSELF (NOT PACKAGED).
- 梱包数量 : 3000 個 / リール  
NUMBER OF CONNECTORS : 3000PCS/REEL
- リードテープ長さ LEAD TAPE LENGTH

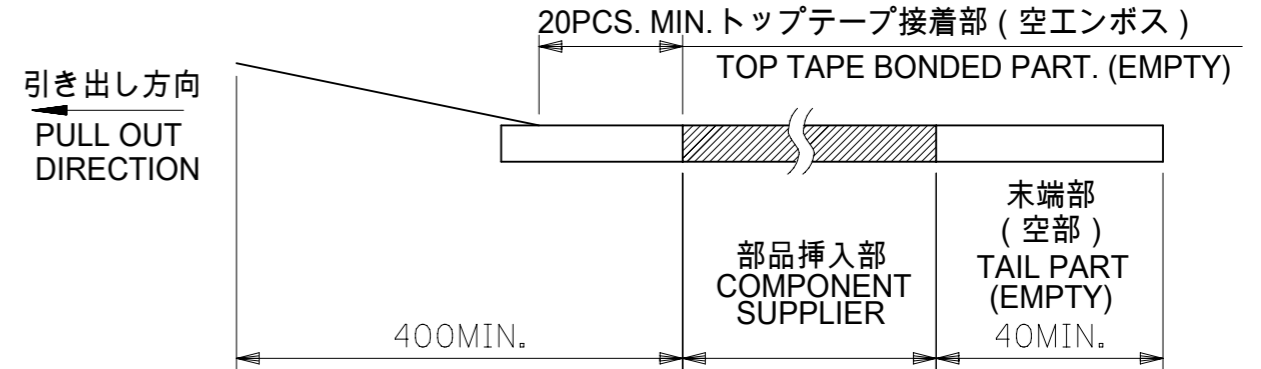

- 材料 MATERIAL  
キャリアテープ (CARRIER TAPE) : ポリスチレン (POLYSTYRENE)  
トップテープ (TOP TAPE) : PET, OTHER  
リール (REEL) : ポリスチレン (PS) <リサイクル材を含む>  
POLYSTYRENE (PS) <RECYCLE MATERIAL CONTAINED>
- ELV及びRoHS適合品  
ELV AND RoHS COMPLIANT

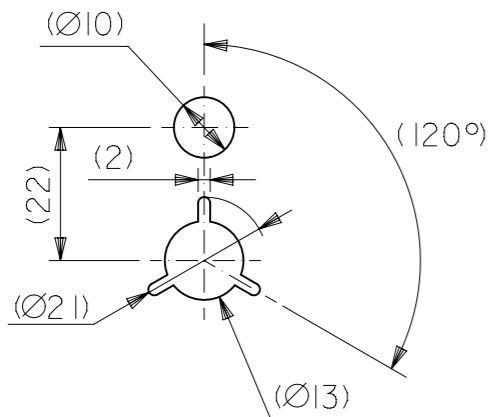
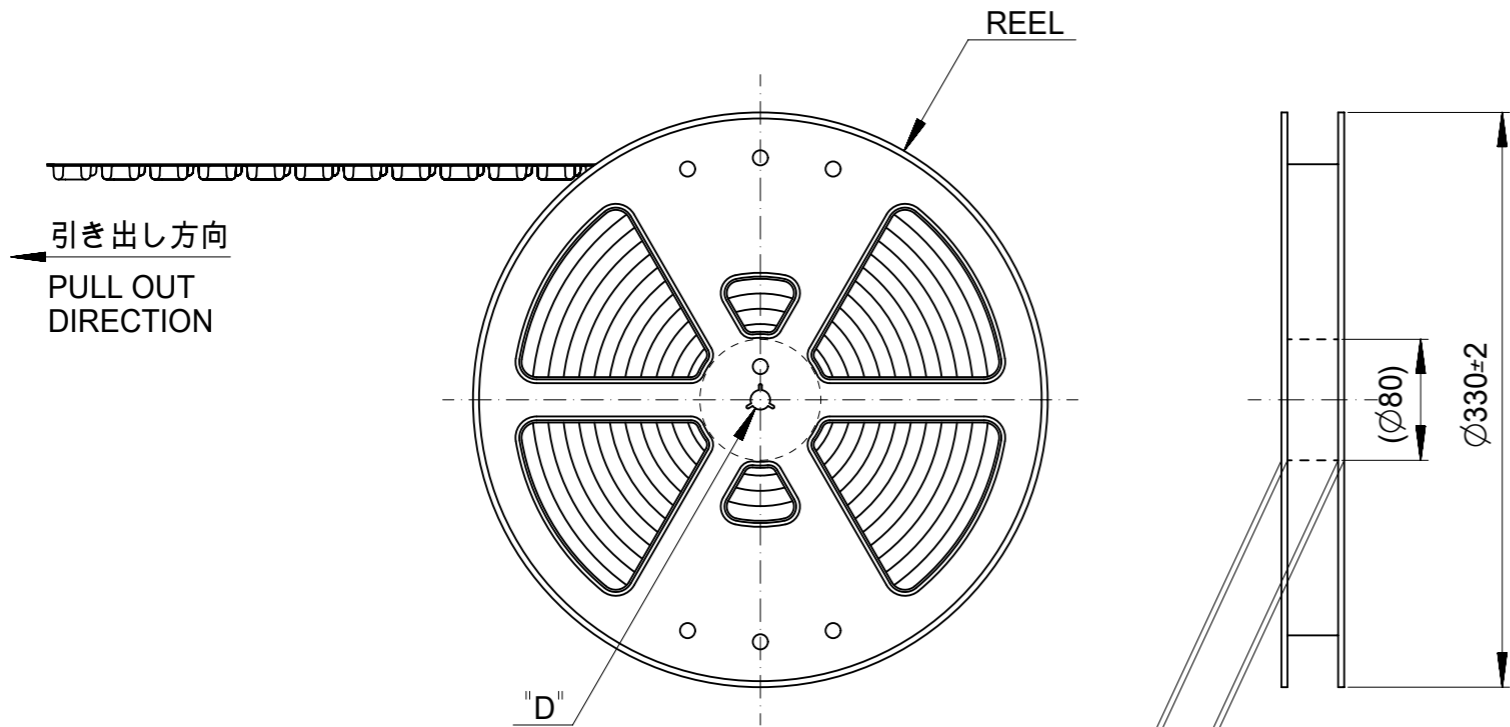

DETAIL "D"



MODEL NO. 502430-\*\*10

SYMBOLS	THIS DRAWING CONTAINS INFORMATION THAT IS PROPRIETARY TO MOLEX ELECTRONIC TECHNOLOGIES, LLC AND SHOULD NOT BE USED WITHOUT WRITTEN PERMISSION		CURRENT REV DESC:		<b>molex</b>			
	▽ = 0	mm						SCALE 1:1
	▽ = 0	GENERAL TOLERANCES (UNLESS SPECIFIED)		EC NO: 622285	0.4 B-TO-B CONN. HGT=1.0 PLUG ASSY EMBSTP PKG			
	▽ = 0	ANGULAR TOL	±	DRWN: KYHWANG 2019/08/13				
▽ = 0	4 PLACES	±	CHK'D: YNAITO 2019/08/13	PRODUCT CUSTOMER DRAWING				
▽ = 0	3 PLACES	±	APPR: RTAKEUCHI 2019/08/13					
▽ = 0	2 PLACES	±	INITIAL REVISION:	DOCUMENT NUMBER				
▽ = 0	1 PLACE	±	DRWN: RTAKEUCHI 2007/10/03				SD-502430-002	
▽ = 0	0 PLACES	±	APPR: MSASAO 2007/10/04	DOC TYPE DOC PART REVISION				
■ = 0	DRAFT WHERE APPLICABLE MUST REMAIN WITHIN DIMENSIONS		THIRD ANGLE PROJECTION				DRAWING	SERIES
▽ = 0			THIRD ANGLE PROJECTION	A3-SIZE	502430		GENERAL MARKET	1 OF 4

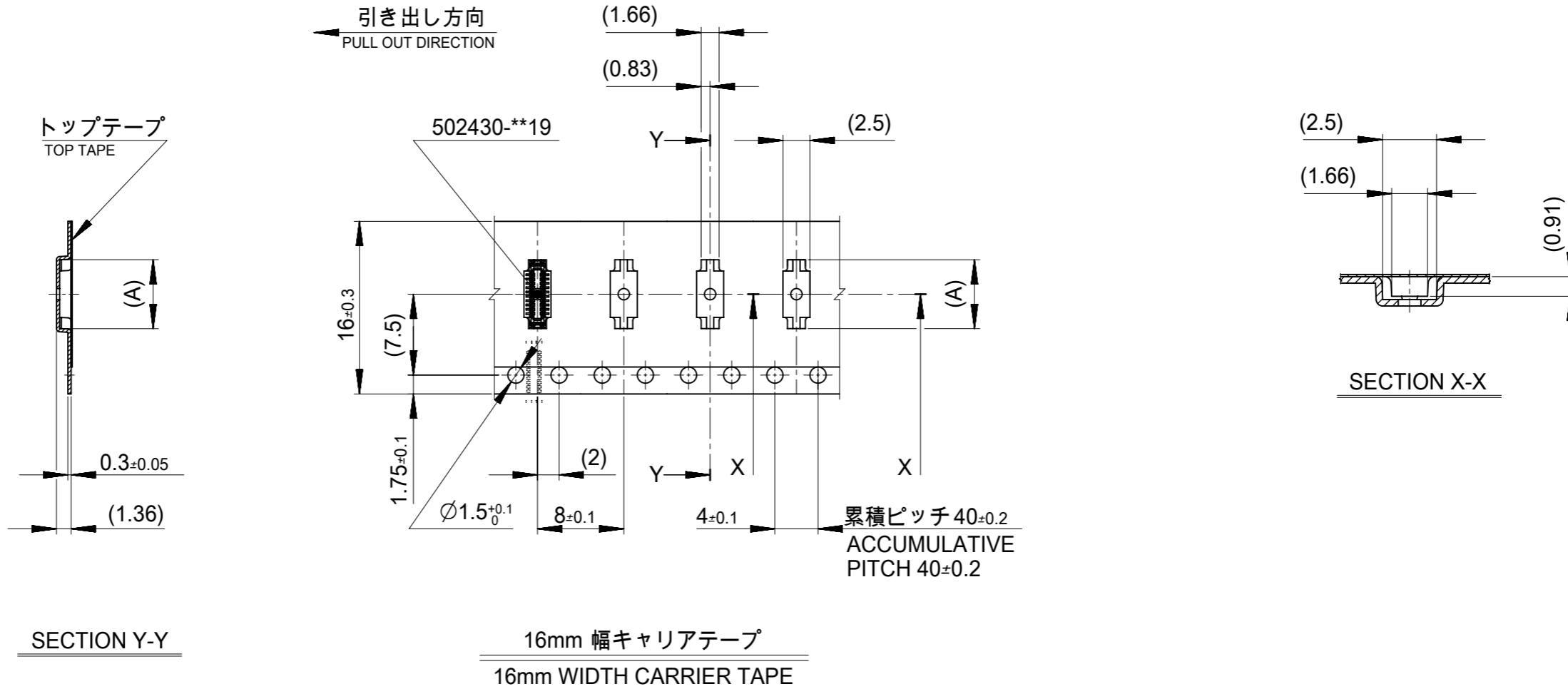

16	21.4	17.4	7.58	502430-2610	26
			7.18	502430-2410	24
			6.78	502430-2210	22
			6.38	502430-2010	20
			5.18	502430-1410	14
キャリアテープ幅 CARRIER TAPE WIDTH			C	B	(A)
			MATERIAL No.	CKT.	
			MODEL No.	502430-**10	

SYMBOLS		THIS DRAWING CONTAINS INFORMATION THAT IS PROPRIETARY TO MOLEX ELECTRONIC TECHNOLOGIES, LLC AND SHOULD NOT BE USED WITHOUT WRITTEN PERMISSION		CURRENT REV DESC:		<b>molex</b>	
▽ = 0	mm	SCALE	4:1	EC NO: 622285			
▽ = 0	GENERAL TOLERANCES (UNLESS SPECIFIED)		DRWN: KYHWANG		2019/08/13	PRODUCT CUSTOMER DRAWING	
▽ = 0	ANGULAR TOL ± °		CHK'D: YNAITO		2019/08/13	DOCUMENT NUMBER	
▽ = 0	4 PLACES ±		APPR: RTAKEUCHI		2019/08/13	SD-502430-002	
▽ = 0	3 PLACES ±		INITIAL REVISION:		DOC TYPE		DOC PART
▽ = 0	2 PLACES ±		DRWN: RTAKEUCHI		2007/10/03	PSD	001
▽ = 0	1 PLACE ±		APPR: MSASAO		2007/10/04	REVISION	
▽ = 0	0 PLACES ±		DRAFT WHERE APPLICABLE MUST REMAIN WITHIN DIMENSIONS		SERIES		K
□ = 0	THIRD ANGLE PROJECTION		DRAWING		A3-SIZE	MATERIAL NUMBER	
▽ = 0	DRAFT WHERE APPLICABLE MUST REMAIN WITHIN DIMENSIONS		SERIES		502430	CUSTOMER	
		THIRD ANGLE PROJECTION		DRAWING		SHEET NUMBER	
		DRAWING		A3-SIZE		GENERAL MARKET	
		SERIES		502430		2 OF 4	



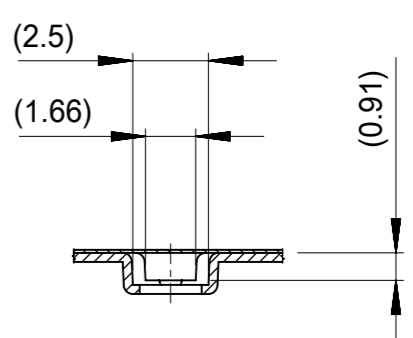
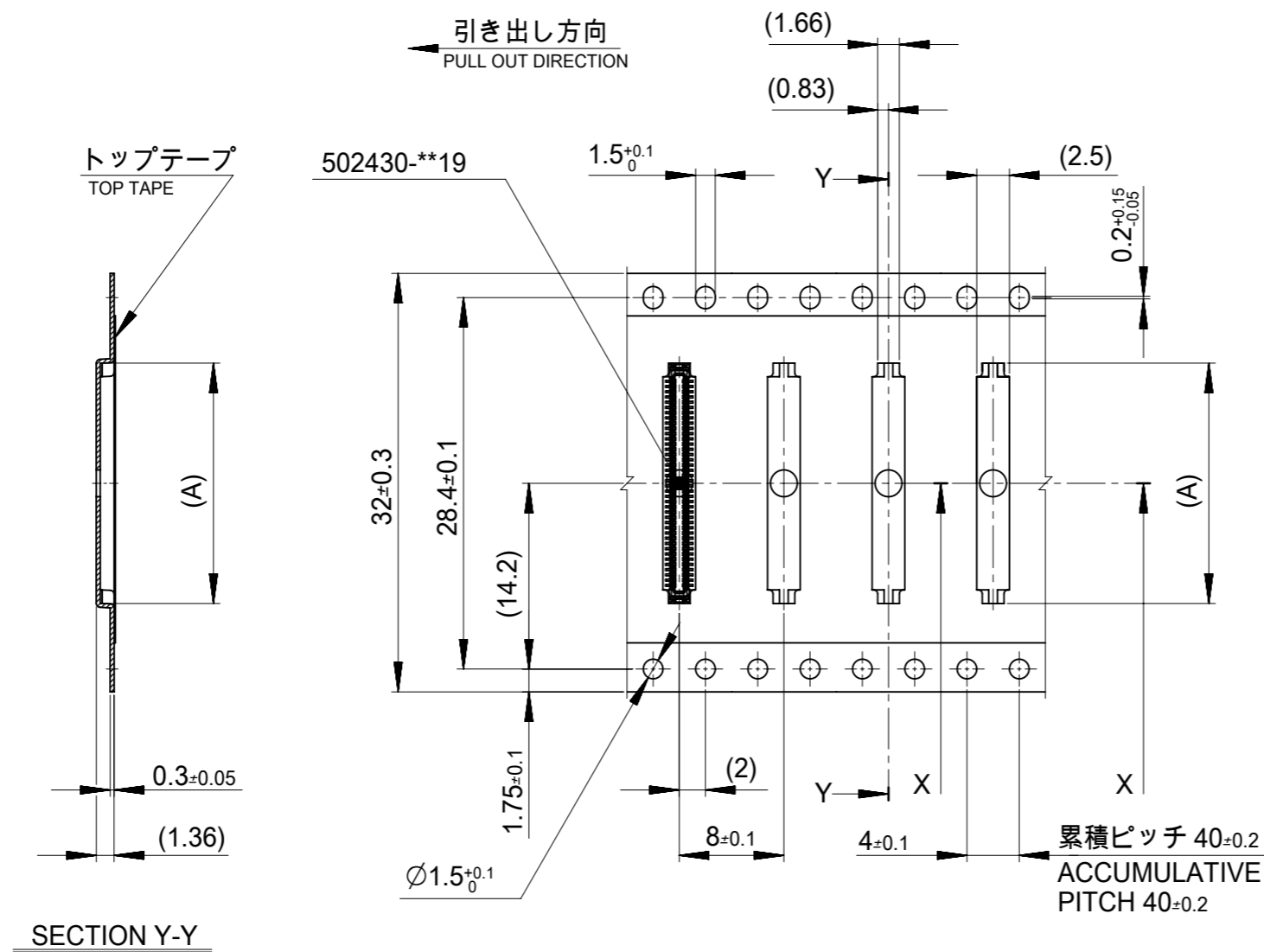

32mm 幅キャリアテープ  
32mm WIDTH CARRIER TAPE

32	37.4	33.4	18.38	502430-8010	80
キャリアテープ幅 CARRIER TAPE WIDTH			C	B	(A)
			MATERIAL No.		CKT.
			MODEL No.		502430-**10
THIS DRAWING CONTAINS INFORMATION THAT IS PROPRIETARY TO MOLEX ELECTRONIC TECHNOLOGIES, LLC AND SHOULD NOT BE USED WITHOUT WRITTEN PERMISSION					
SYMBOLS		CURRENT REV DESC:		<b>molex</b>	
DIMENSION UNITS		SCALE			
mm		1:1		0.4 B-TO-B CONN. HGT=1.0 PLUG ASSY EMBSTP PKG	
GENERAL TOLERANCES (UNLESS SPECIFIED)		EC NO: 622285		PRODUCT CUSTOMER DRAWING	
ANGULAR TOL ± °		DRWN: KYHWANG 2019/08/13		DOCUMENT NUMBER	
4 PLACES ±		CHK'D: YNAITO 2019/08/13		SD-502430-002	
3 PLACES ±		APPR: RTAKEUCHI 2019/08/13		DOC TYPE	
2 PLACES ±		INITIAL REVISION:		DOC PART	
1 PLACE ±		DRWN: RTAKEUCHI 2007/10/03		REVISION	
0 PLACES ±		APPR: MSASAO 2007/10/04		K	
DRAFT WHERE APPLICABLE MUST REMAIN WITHIN DIMENSIONS		THIRD ANGLE PROJECTION		MATERIAL NUMBER	
		DRAWING		CUSTOMER	
		A3-SIZE		GENERAL MARKET	
		SERIES		SHEET NUMBER	
		502430		4 OF 4	