

THIS DRAWING IS UNPUBLISHED. DIFFUSION RESTREINTE
 RELEASED FOR PUBLICATION LIBRE A LA DIFFUSION
 ALL RIGHTS RESERVED. TOUS DROITS RESERVES

REVISIONS					
P	LTR	DESCRIPTION MODIFICATIONS	DATE	DWN. DESS.	APVD. APP.
	K2	PLATING NOTE CORRECTED	02AUG2016	KJK	PS

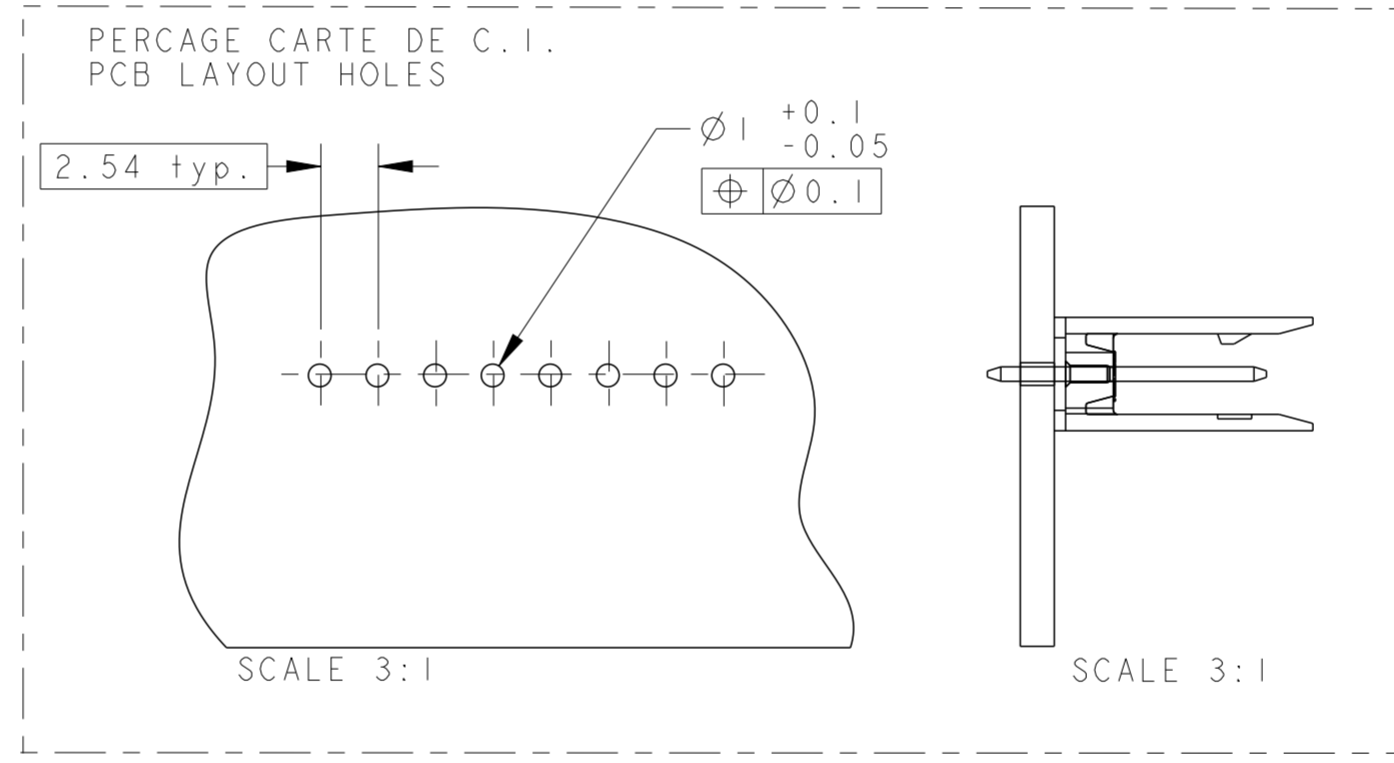
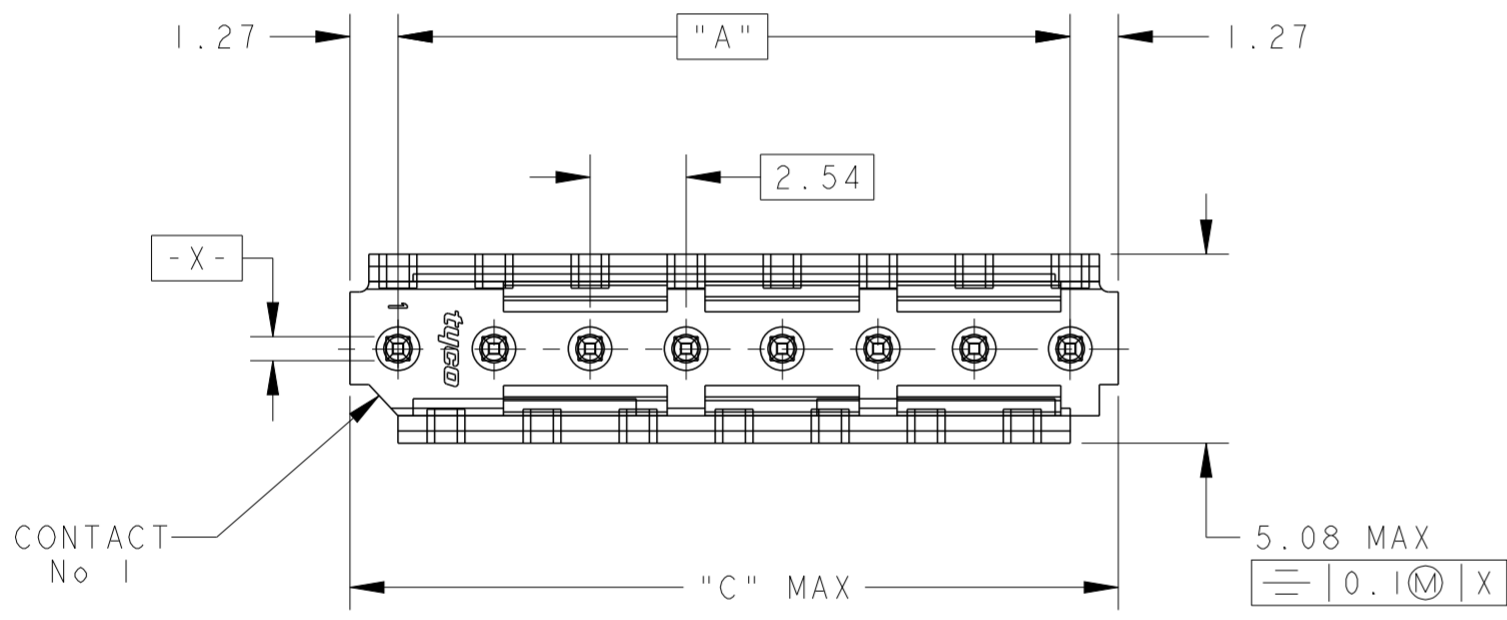
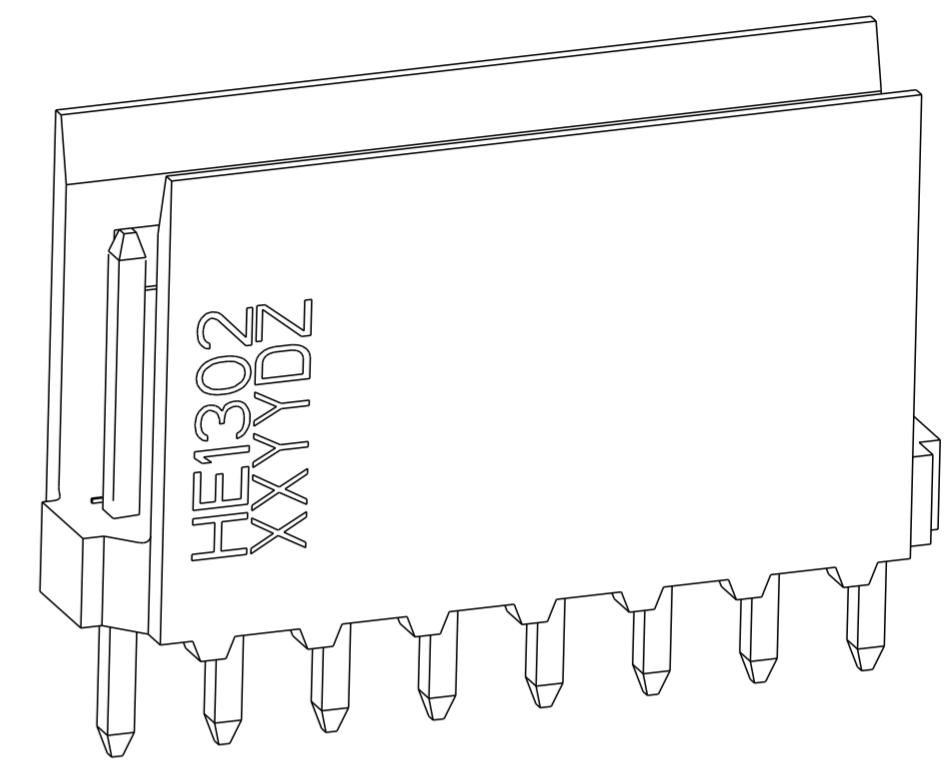
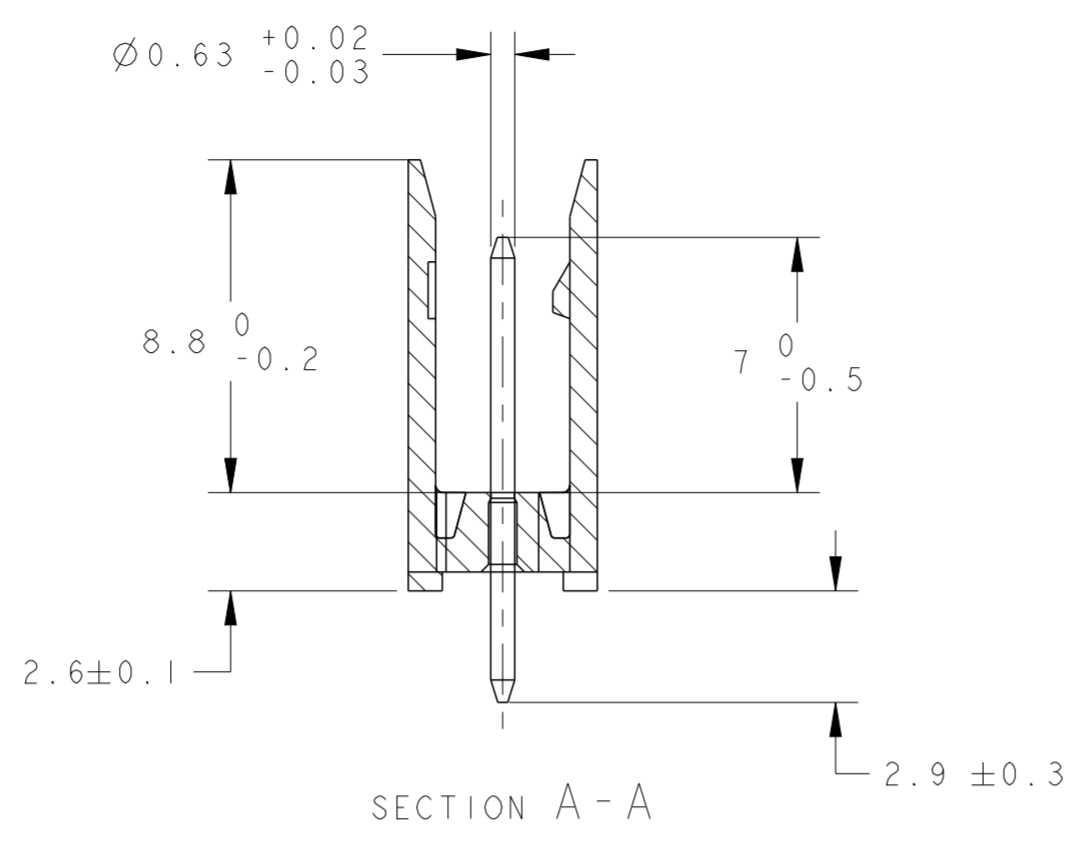
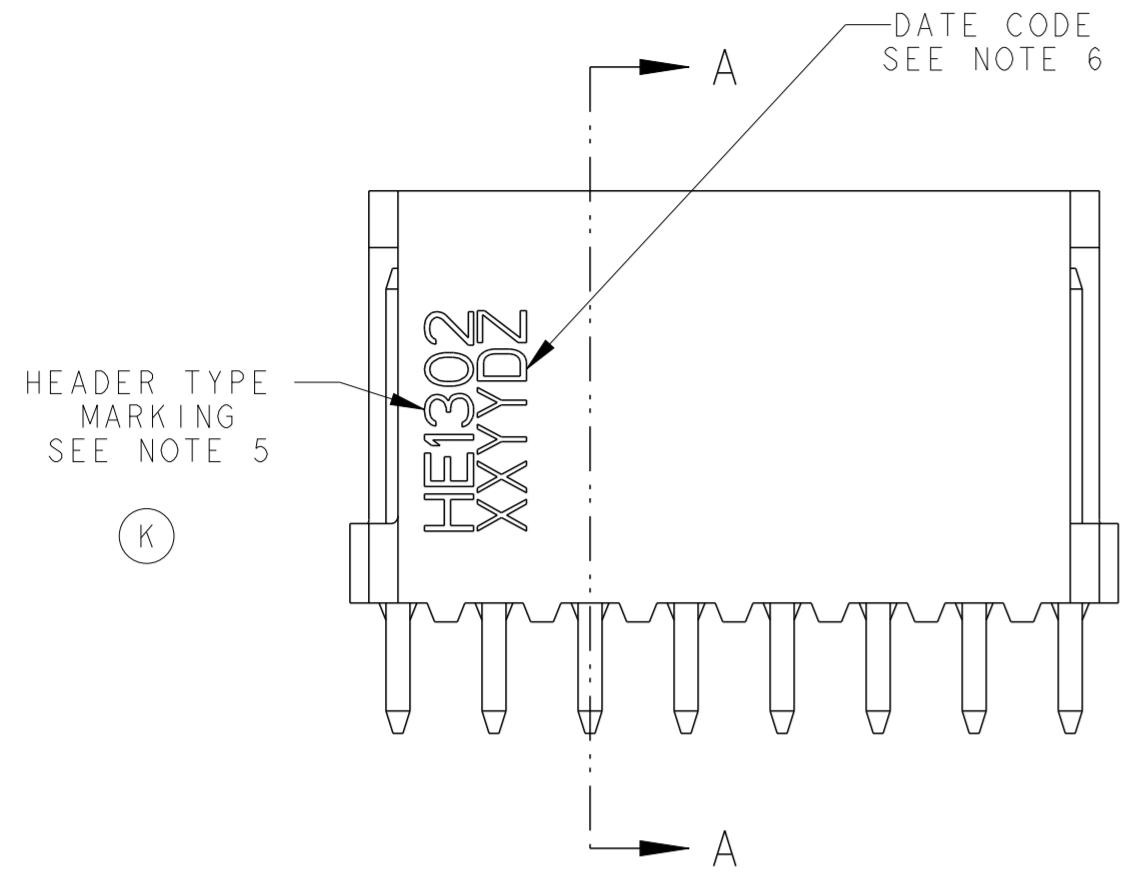

7 OBSOLETE	45.72	43.18	18	1-281696-8 *
	43.18	40.64	17	1-281696-7
	38.10	35.56	15	1-281696-5 *
	30.48	27.94	12	1-281696-2 *
	25.40	22.86	10	1-281696-0 *
	20.32	17.78	8	0-281696-8 *
	17.78	15.24	7	0-281696-7
	15.24	12.70	6	0-281696-6 *
	12.70	10.16	5	0-281696-5 *
	10.16	7.62	4	0-281696-4 *
	7.62	5.08	3	0-281696-3 *
	5.08	2.54	2	0-281696-2
	C	A	Nb DE POS	PART NUMBER
	DIMENSIONS			

- NOTES:
- THESE HEADERS ARE DESIGNED TO BE MATED WITH "HE1302" RECEPTACLES SINGLE ROW
 - THE PART NUMBERS FOLLOWED BY * ARE COVERED BY INTERNATIONAL STANDARD IEC 603-8
 - CONTACTS PLATING: MATING AREA, MIN. 0.4µm SELECTIVE GOLD OVER MIN. 1.27µm NICKEL
SOLDER AREA, MIN. 2.5µm TIN OVER MIN. 1.27µm NICKEL
 - PLASTIC MATERIAL: HIGH TEMPERATURE THERMOPLASTIC, UL-94V-0, BLUE COLOR
CONTACT MATERIAL: PHOSPHOR BRONZE
 - TYPE MARKING (HE1302) WITH BLACK INK
 - DATE CODE MARKING WITH BLACK INK

7 OBSOLETE PARTS: OBSOLETE CIS STREAMLINING PER D.RENAUD/D.SINISI

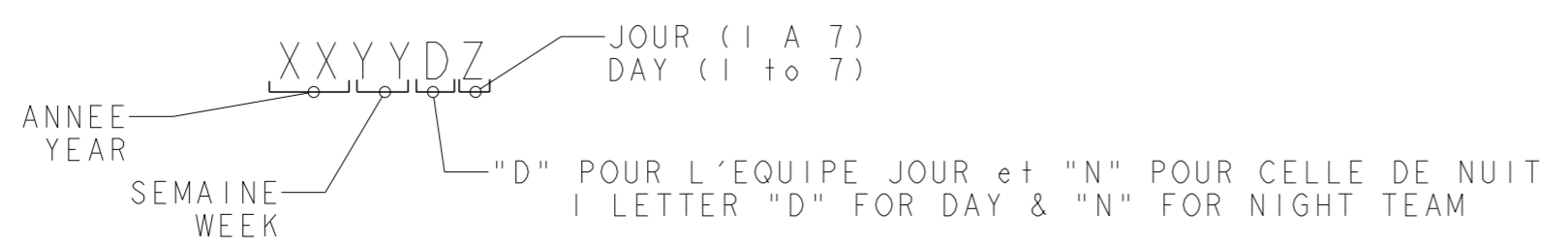

THIS DRAWING IS A CONTROLLED DOCUMENT. CE PLAN EST UN DOCUMENT CONTROLE PAR AMP INCORPORATED. IL EST SUSCEPTIBLE D'ETRE REVISE. CONTACTER LE SERVICE TECHNIQUE D'AMP DE FRANCE POUR OBTENIR LA DERNIERE REVISION.		DWN/DESSINE 22NOV2000 C. COMBEDOUZON CHK/VERIFIE 22NOV2000 T. CORRIOL APVD/APPROUVE 22NOV2000 Y. PETRONIN		TE Connectivity	
DIMENSIONS: mm		TOLERANCES UNLESS OTHERWISE SPECIFIED: (SUIV NB DE DECIMALES) 0 PLC/DEC: ± 1 PLC/DEC: ±0.3 2 PLC/DEC: ± 3 PLC/DEC: ± 4 PLC/DEC: ± ANGLES ±5°		NAME: HEADERS HE13, SINGLE ROW, STRAIGHT	
MATERIAL/MATIERE: SEE/VOIR NOTE 4		FINISH/FINITION: SEE/VOIR NOTE 3		PRODUCT SPEC: 108-15053	
WEIGHT MASSE APPROX. -		APPLICATION SPEC: -		SIZE FORMAT: A2	
CUSTOMER DRAWING /PLAN CLIENT		UNIQUEMENT POUR REFERENCE		DRAWING NO: C-281696	
SCALE ECHELLE: 5:1		SHEET FEUILLE: 1 OF DE: 1		RESTRICTED TO RESERVE A: -	
				REV: K2	