

## HRDS SERIES

### Single Shot Timer

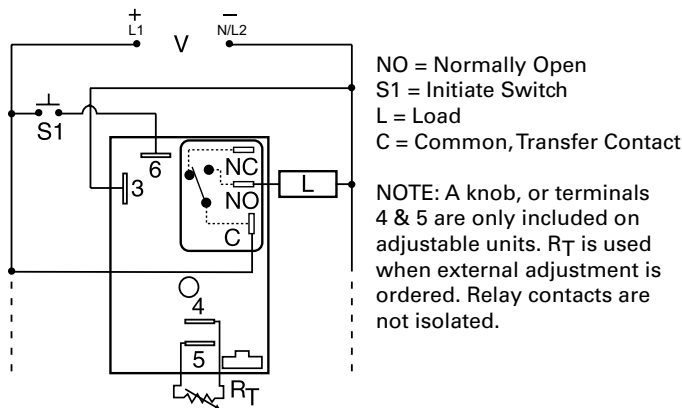

### Wiring Diagram



### Ordering Information

MODEL	INPUT VOLTAGE	ADJUSTMENT	TIME DELAY
HRDS120	12VDC	Onboard	0.1 - 10s
HRDS313M	24VDC	Fixed	3m
HRDS321	24VDC	Onboard	1 - 100s
HRDS421	120VAC	Onboard	1 - 100s
HRDS430	120VAC	External	0.1 - 10s

If you don't find the part you need, call us for a custom product 800-843-8848

### Description

The HRDS Series combines an electromechanical relay output with microcontroller timing circuitry. It offers 12 to 230V operation in five options and factory fixed, onboard or external adjustable time delays with a repeat accuracy of  $\pm 0.5\%$ . The output contact rating allows for direct operation of heavy loads, such as compressors, pumps, blower motors, heaters, etc. This series is ideal for OEM applications where cost is a factor.

#### Operation (Single Shot)

Input voltage must be applied before and during timing. Upon momentary or maintained closure of the initiate switch, the output relay energizes for a measured interval of time. At the end of the delay, the output de-energizes. Opening or reclosing the initiate switch during timing has no effect on the time delay. The output will energize if the initiate switch is closed when input voltage is applied.

**Reset:** Reset occurs when the time delay is complete and the initiate switch is opened. Loss of input voltage resets the time delay and output.

### Features & Benefits

FEATURES	BENEFITS
<b>Microcontroller based</b>	Repeat Accuracy $\pm 0.5\%$
<b>Compact, low cost design</b>	Allows flexibility for OEM applications
<b>Isolated, 30A, SPDT, NO output contacts</b>	Allows direct operation of heavy loads: compressors, pumps, blower motors, heaters.
<b>Encapsulated</b>	Protects against shock, vibration, and humidity

### Accessories



#### P1004-95, P1004-95-X Versa-Pot

Panel mountable, industrial potentiometer recommended for remote time delay adjustment.



#### P1023-6 Mounting bracket

The 90° orientation of mounting slots makes installation/removal of modules quick and easy.



#### P0700-7 Versa-Knob

Designed for 0.25 in. (6.35 mm) shaft of Versa-Pot. Semi-gloss industrial black finish.



#### P1015-13 (AWG 10/12), P1015-64 (AWG 14/16) Female Quick Connect

These 0.25 in. (6.35 mm) female terminals are constructed with an insulator barrel to provide strain relief.



#### P1015-18 Quick Connect to Screw Adapter

Screw adapter terminal designed for use with all modules with 0.25 in. (6.35 mm) male quick connect terminals.

## HRDS SERIES

### Accessories



**C103PM (AL) DIN Rail**  
35 mm aluminum DIN rail available in a 36 in. (91.4 cm) length.

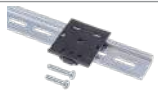

**P1023-20 DIN Rail Adapter**  
Allows module to be mounted on a 35 mm DIN type rail with two #10 screws.

\*8-pin models UL listed when used in combination with P1011-6 socket only.

### External Resistance vs. Time Delay

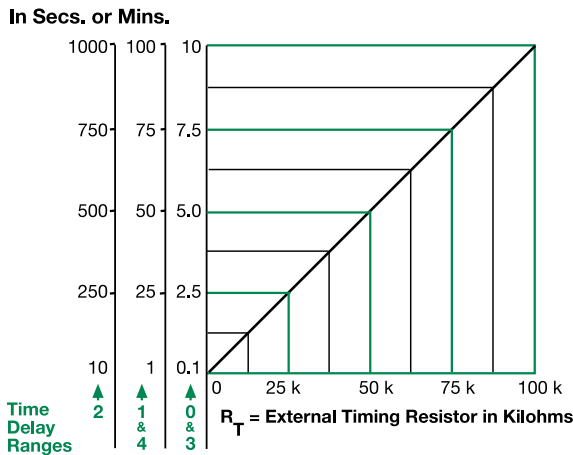

This chart applies to externally adjustable part numbers. The time delay is adjustable over the time delay range selected by varying the resistance across the R<sub>T</sub> terminals; as the resistance increases the time delay increases. When selecting an external R<sub>T</sub>, add the tolerances of the timer and the R<sub>T</sub> for the full time range adjustment.  
**Examples:** 1 to 50 S adjustable time delay, select time delay range 1 and a 50 K ohm R<sub>T</sub>. For 1 to 100 S use a 100 K ohm R<sub>T</sub>.

### Function Diagram

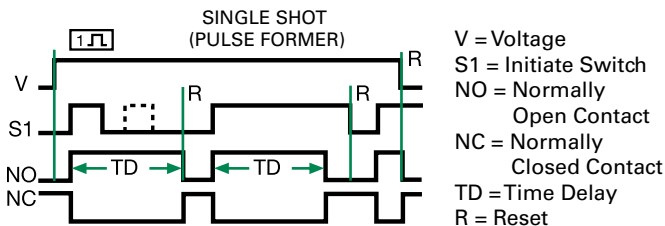

### Specifications

#### Time Delay

**Type** Microcontroller circuitry  
**Range** 0.1s - 100m in 5 adjustable ranges or fixed  
**Repeat Accuracy** ±0.5% or 20 ms, whichever is greater

**Tolerance** ±1%, ±5%  
**(Factory Calibration)**  
**Reset Time** ≤ 150ms  
**Initiate Time** ≤ 20ms

**Time Delay vs Temp. & Voltage** ±2%

#### Input

**Voltage** 12 or 24VDC; 24, 120, or 230VAC

**Tolerance**  
**12VDC & 24VDC** -15% - 20%  
**24 to 230VAC** -20% - 10%

**AC Line Frequency** 50/60 Hz  
**Power Consumption** AC ≤ 4VA; DC ≤ 2W

#### Output

**Type** Electromechanical relay  
**Form** SPDT, non-isolated

Ratings	SPDT-NO	SPDT-NC
<b>General Purpose</b> 125/240VAC	30A	15A
<b>Resistive</b> 125/240VAC	30A	15A
28VDC	20A	10A
<b>Motor Load</b> 125VAC	1 hp*	1/4 hp**
240VAC	2 hp**	1 hp**

**Life** Mechanical - 1 x 10<sup>6</sup>;  
Electrical - 1 x 10<sup>5</sup>, \*3 x 10<sup>4</sup>, \*\*6,000

#### Protection

**Surge** IEEE C62.41-1991 Level A  
**Circuitry** Encapsulated  
**Dielectric Breakdown** ≥ 2000V RMS terminals to mounting surface  
**Insulation Resistance** ≥ 100 MΩ  
**Polarity** DC units are reverse polarity protected

#### Mechanical

**Mounting** Surface mount with one #10 (M5 x 0.8) screw  
**Dimensions** **H** 76.7 mm (3"); **W** 51.3 mm (2");  
**D** 38.1 mm (1.5")  
**Termination** 0.25 in. (6.35 mm) male quick connect terminals

#### Environmental

**Operating/Storage Temperature** -40° to 60°C/-40° to 85°C  
**Humidity** 95% relative, non-condensing  
**Weight** ≈ 3.9 oz (111 g)