

FEATURES

- 1 pF off capacitance
- 2.6 pF on capacitance
- <1 pC charge injection
- 33 V supply range
- 120 Ω on resistance
- Fully specified at ± 15 V, +12 V
- No V_L supply required
- 3 V logic-compatible inputs
- Rail-to-rail operation
- 16-lead TSSOP
- Typical power consumption: <0.03 μ W

ENHANCED PRODUCT FEATURES

- Supports defense and aerospace applications (AQEC standard)
- Military temperature range: -55°C to $+125^\circ\text{C}$
- Controlled manufacturing baseline
- 1 assembly/test site
- 1 fabrication site
- Product change notification
- Qualification data available on request

APPLICATIONS

- Automatic test equipment
- Data acquisition systems
- Battery-powered systems
- Sample-and-hold systems
- Audio signal routing
- Video signal routing
- Communication systems

GENERAL DESCRIPTION

The **ADG1212-EP** is a monolithic complementary metal-oxide semiconductor (CMOS) device containing four independently selectable switches designed on an *i*CMOS[®] (industrial CMOS) process. *i*CMOS is a modular manufacturing process combining high voltage CMOS and bipolar technologies. It enables the development of a wide range of high performance analog ICs capable of 33 V operation in a footprint that no previous generation of high voltage parts has been able to achieve. Unlike analog ICs using conventional CMOS processes, *i*CMOS components can tolerate high supply voltages while providing increased performance, dramatically lower power consumption, and reduced package size.

FUNCTIONAL BLOCK DIAGRAM

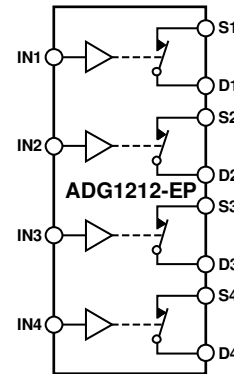

NOTES
1. SWITCHES SHOWN ARE FOR LOGIC 1 INPUT.

Figure 1.

10012-001

The ultralow capacitance and charge injection of this switch makes it an ideal solution for data acquisition and sample-and-hold applications, where low glitch and fast settling are required. Fast switching speed coupled with high signal bandwidth makes the part suitable for video signal switching.

*i*CMOS construction ensures ultralow power dissipation, making the part ideally suited for portable and battery-powered instruments.

The **ADG1212-EP** contains four independent single-pole/single-throw (SPST) switches. Each switch conducts equally well in both directions when on and has an input signal range that extends to the supplies. In the off condition, signal levels up to the supplies are blocked.

Additional application and technical information can be found in the **ADG1212** data sheet.

PRODUCT HIGHLIGHTS

1. Ultralow capacitance.
2. <1 pC charge injection.
3. 3 V logic compatible digital inputs: $V_{IH} = 2.0$ V, $V_{IL} = 0.8$ V.
4. No V_L logic power supply required.
5. Ultralow power dissipation: <0.03 μ W.
6. 16-lead TSSOP package.

Rev. B

[Document Feedback](#)

Information furnished by Analog Devices is believed to be accurate and reliable. However, no responsibility is assumed by Analog Devices for its use, nor for any infringements of patents or other rights of third parties that may result from its use. Specifications subject to change without notice. No license is granted by implication or otherwise under any patent or patent rights of Analog Devices. Trademarks and registered trademarks are the property of their respective owners.

TABLE OF CONTENTS

Features	1	Single Supply	4
Enhanced Product Features	1	Absolute Maximum Ratings	5
Applications	1	ESD Caution.....	5
General Description	1	Pin Configuration and Function Descriptions.....	6
Functional Block Diagram	1	Typical Performance Characteristics	7
Product Highlights	1	Test Circuits.....	9
Revision History	2	Outline Dimensions	11
Specifications.....	3	Ordering Guide	11
Dual Supply	3		

REVISION HISTORY

5/2018—Rev. A to Rev. B

Change to Enhanced Product Features Section	1
Changes to Ordering Guide	11

7/2012—Rev. 0 to Rev. A

Changed Operating Temperature Range from -40°C to $+125^{\circ}\text{C}$ to -55°C to $+125^{\circ}\text{C}$; Table 3.....	5
---	---

11/2011—Revision 0: Initial Version

SPECIFICATIONS

DUAL SUPPLY

$V_{DD} = 15\text{ V} \pm 10\%$, $V_{SS} = -15\text{ V} \pm 10\%$, GND = 0 V, unless otherwise noted.

Table 1.

Parameter	25°C	-40°C to +85°C	-55°C to +125°C	Unit	Test Conditions/Comments
ANALOG SWITCH					
Analog Signal Range				V	
On Resistance (R_{ON})	120			Ω typ	$V_S = \pm 10\text{ V}$, $I_S = -1\text{ mA}$; see Figure 15
	190	230	260	Ω max	$V_{DD} = +13.5\text{ V}$, $V_{SS} = -13.5\text{ V}$
On Resistance Match Between Channels (ΔR_{ON})	2.5			Ω typ	$V_S = \pm 10\text{ V}$, $I_S = -1\text{ mA}$
	6	10	11	Ω max	
On Resistance Flatness ($R_{FLAT(ON)}$)	20			Ω typ	$V_S = -5\text{ V}/0\text{ V}/+5\text{ V}$; $I_S = -1\text{ mA}$
	57	72	79	Ω max	
LEAKAGE CURRENTS					
Source Off Leakage, I_S (Off)	± 0.02			nA typ	$V_{DD} = +16.5\text{ V}$, $V_{SS} = -16.5\text{ V}$
	± 0.1	± 0.6	± 1	nA max	$V_S = \pm 10\text{ V}$, $V_D = \pm 10\text{ V}$; see Figure 11
Drain Off Leakage, I_D (Off)	± 0.02			nA typ	$V_S = \pm 10\text{ V}$, $V_D = \pm 10\text{ V}$; see Figure 11
	± 0.1	± 0.6	± 1	nA max	
Channel On Leakage, I_D , I_S (On)	± 0.02			nA typ	$V_S = V_D = \pm 10\text{ V}$; see Figure 12
	± 0.1	± 0.6	± 1	nA max	
DIGITAL INPUTS					
Input High Voltage, V_{INH}			2.0	V min	
Input Low Voltage, V_{INL}			0.8	V max	
Input Current, I_{INL} or I_{INH}	0.005			μA typ	$V_{IN} = V_{INL}$ or V_{INH}
			± 0.1	μA max	
Digital Input Capacitance, C_{IN}	2.5			pF typ	
DYNAMIC CHARACTERISTICS¹					
t_{ON}	65			ns typ	$R_L = 300\ \Omega$, $C_L = 35\text{ pF}$
	80	95	110	ns max	$V_S = 10\text{ V}$; see Figure 18
t_{OFF}	80			ns typ	$R_L = 300\ \Omega$, $C_L = 35\text{ pF}$
	100	115	135	ns max	$V_S = 10\text{ V}$; see Figure 18
Charge Injection	-0.3			pC typ	$V_S = 0\text{ V}$, $R_S = 0\ \Omega$, $C_L = 1\text{ nF}$; see Figure 19
Off Isolation	80			dB typ	$R_L = 50\ \Omega$, $C_L = 5\text{ pF}$, $f = 1\text{ MHz}$; see Figure 13
Channel-to-Channel Crosstalk	90			dB typ	$R_L = 50\ \Omega$, $C_L = 5\text{ pF}$, $f = 1\text{ MHz}$; see Figure 14
Total Harmonic Distortion + Noise	0.15			% typ	$R_L = 10\text{ k}\Omega$, 5 V rms, $f = 20\text{ Hz}$ to 20 kHz; see Figure 17
-3 dB Bandwidth	1000			MHz typ	$R_L = 50\ \Omega$, $C_L = 5\text{ pF}$; see Figure 16
C_S (Off)	0.9			pF typ	$V_S = 0\text{ V}$, $f = 1\text{ MHz}$
	1.1			pF max	$V_S = 0\text{ V}$, $f = 1\text{ MHz}$
C_D (Off)	1			pF typ	$V_S = 0\text{ V}$, $f = 1\text{ MHz}$
	1.2			pF max	$V_S = 0\text{ V}$, $f = 1\text{ MHz}$
C_D , C_S (On)	2.6			pF typ	$V_S = 0\text{ V}$, $f = 1\text{ MHz}$
	3			pF max	$V_S = 0\text{ V}$, $f = 1\text{ MHz}$
POWER REQUIREMENTS					
I_{DD}	0.001			μA typ	$V_{DD} = +16.5\text{ V}$, $V_{SS} = -16.5\text{ V}$
			1.0	μA max	Digital inputs = 0 V or V_{DD}
I_{DD}	220			μA typ	Digital inputs = 5 V
			420	μA max	
I_{SS}	0.001			μA typ	Digital inputs = 0 V or V_{DD}
			1.0	μA max	
I_{SS}	0.001			μA typ	Digital inputs = 5 V
			1.0	μA max	

¹ Guaranteed by design, not subject to production test.

SINGLE SUPPLY

$V_{DD} = 12\text{ V} \pm 10\%$, $V_{SS} = 0\text{ V}$, $GND = 0\text{ V}$, unless otherwise noted.

Table 2.

Parameter	25°C	-40°C to +85°C	-55°C to +125°C	Unit	Test Conditions/Comments
ANALOG SWITCH					
Analog Signal Range			0 V to V_{DD}	V	
On Resistance (R_{ON})	300			Ω typ	$V_S = 0\text{ V to }10\text{ V}$, $I_S = -1\text{ mA}$; see Figure 15
	475	567	625	Ω max	$V_{DD} = 10.8\text{ V}$, $V_{SS} = 0\text{ V}$
On Resistance Match Between Channels (ΔR_{ON})	4.5			Ω typ	$V_S = 0\text{ V to }10\text{ V}$, $I_S = -1\text{ mA}$
	12	26	27	Ω max	
On Resistance Flatness ($R_{FLAT(ON)}$)	60			Ω typ	$V_S = 3\text{ V}/6\text{ V}/9\text{ V}$, $I_S = -1\text{ mA}$
LEAKAGE CURRENTS					
Source Off Leakage, I_S (Off)	± 0.02			nA typ	$V_{DD} = 13.2\text{ V}$, $V_{SS} = 0\text{ V}$
	± 0.1	± 0.6	± 1	nA max	$V_S = 1\text{ V}/10\text{ V}$, $V_D = 10\text{ V}/1\text{ V}$; see Figure 11
Drain Off Leakage, I_D (Off)	± 0.02			nA typ	$V_S = 1\text{ V}/10\text{ V}$, $V_D = 10\text{ V}/1\text{ V}$; see Figure 11
	± 0.1	± 0.6	± 1	nA max	
Channel On Leakage, I_D , I_S (On)	± 0.02			nA typ	$V_S = V_D = 1\text{ V or }10\text{ V}$; see Figure 12
	± 0.1	± 0.6	± 1	nA max	
DIGITAL INPUTS					
Input High Voltage, V_{INH}			2.0	V min	
Input Low Voltage, V_{INL}			0.8	V max	
Input Current, I_{INL} or I_{INH}	0.001			μA typ	$V_{IN} = V_{INL}$ or V_{INH}
			± 0.1	μA max	
Digital Input Capacitance, C_{IN}	3			pF typ	
DYNAMIC CHARACTERISTICS¹					
t_{ON}	80			ns typ	$R_L = 300\ \Omega$, $C_L = 35\text{ pF}$
	105	125	140	ns max	$V_S = 8\text{ V}$; see Figure 18
t_{OFF}	90			ns typ	$R_L = 300\ \Omega$, $C_L = 35\text{ pF}$
	115	140	165	ns max	$V_S = 8\text{ V}$; see Figure 18
Charge Injection	0			pC typ	$V_S = 6\text{ V}$, $R_S = 0\ \Omega$, $C_L = 1\text{ nF}$; see Figure 19
Off Isolation	80			dB typ	$R_L = 50\ \Omega$, $C_L = 5\text{ pF}$, $f = 1\text{ MHz}$; see Figure 13
Channel-to-Channel Crosstalk	90			dB typ	$R_L = 50\ \Omega$, $C_L = 5\text{ pF}$, $f = 1\text{ MHz}$; see Figure 14
-3 dB Bandwidth	900			MHz typ	$R_L = 50\ \Omega$, $C_L = 5\text{ pF}$; see Figure 16
C_S (Off)	1.2			pF typ	$V_S = 6\text{ V}$, $f = 1\text{ MHz}$
	1.4			pF max	$V_S = 6\text{ V}$, $f = 1\text{ MHz}$
C_D (Off)	1.3			pF typ	$V_S = 6\text{ V}$, $f = 1\text{ MHz}$
	1.5			pF max	$V_S = 6\text{ V}$, $f = 1\text{ MHz}$
C_D , C_S (On)	3.2			pF typ	$V_S = 6\text{ V}$, $f = 1\text{ MHz}$
	3.9			pF max	$V_S = 6\text{ V}$, $f = 1\text{ MHz}$
POWER REQUIREMENTS					
I_{DD}	0.001			μA typ	$V_{DD} = 13.2\text{ V}$
			1.0	μA max	Digital inputs = 0 V or V_{DD}
I_{DD}	220			μA typ	Digital inputs = 5 V
			420	μA max	

¹ Guaranteed by design, not subject to production test.

ABSOLUTE MAXIMUM RATINGS

$T_A = 25^\circ\text{C}$, unless otherwise noted.

Table 3.

Parameter	Rating
V_{DD} to V_{SS}	35 V
V_{DD} to GND	-0.3 V to +25 V
V_{SS} to GND	+0.3 V to -25 V
Analog Inputs ¹	$V_{SS} - 0.3\text{ V}$ to $V_{DD} + 0.3\text{ V}$ or 30 mA, whichever occurs first
Digital Inputs ¹	GND - 0.3 V to $V_{DD} + 0.3\text{ V}$ or 30 mA, whichever occurs first
Peak Current, S or D	100 mA (pulsed at 1 ms, 10% duty cycle maximum)
Continuous Current per Channel, S or D	25 mA
Operating Temperature Range	-55°C to +125°C
Storage Temperature Range	-65°C to +150°C
Junction Temperature	150°C
16-Lead TSSOP, θ_{JA} Thermal Impedance (4-Layer Board)	112°C/W
Lead Temperature, Soldering	As per JEDEC J-STD-020

¹ Overvoltages at IN, S, or D are clamped by internal diodes. Current should be limited to the maximum ratings given.

Stresses at or above those listed under Absolute Maximum Ratings may cause permanent damage to the product. This is a stress rating only; functional operation of the product at these or any other conditions above those indicated in the operational section of this specification is not implied. Operation beyond the maximum operating conditions for extended periods may affect product reliability.

Only one absolute maximum rating may be applied at any one time.

Table 4. ADG1212-EP Truth Table

ADG1212-EP INx	Switch Condition
1	On
0	Off

ESD CAUTION



ESD (electrostatic discharge) sensitive device. Charged devices and circuit boards can discharge without detection. Although this product features patented or proprietary protection circuitry, damage may occur on devices subjected to high energy ESD. Therefore, proper ESD precautions should be taken to avoid performance degradation or loss of functionality.

PIN CONFIGURATION AND FUNCTION DESCRIPTIONS

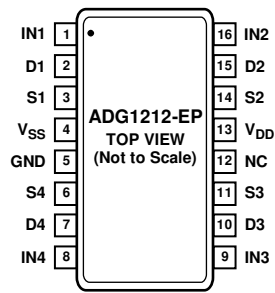

NOTES
 1. NC = NO CONNECT. DO NOT CONNECT TO THIS PIN.

10012-002

Figure 2. Pin Configuration

Table 5. Pin Function Descriptions

Pin No.	Mnemonic	Description
1	IN1	Logic Control Input.
2	D1	Drain Terminal. This pin can be an input or output.
3	S1	Source Terminal. This pin can be an input or output.
4	V _{SS}	Most Negative Power Supply Potential.
5	GND	Ground (0 V) Reference.
6	S4	Source Terminal. This pin can be an input or output.
7	D4	Drain Terminal. This pin can be an input or output.
8	IN4	Logic Control Input.
9	IN3	Logic Control Input.
10	D3	Drain Terminal. This pin can be an input or output.
11	S3	Source Terminal. This pin can be an input or output.
12	NC	No Connection.
13	V _{DD}	Most Positive Power Supply Potential.
14	S2	Source Terminal. This pin can be an input or output.
15	D2	Drain Terminal. This pin can be an input or output.
16	IN2	Logic Control Input.

TYPICAL PERFORMANCE CHARACTERISTICS

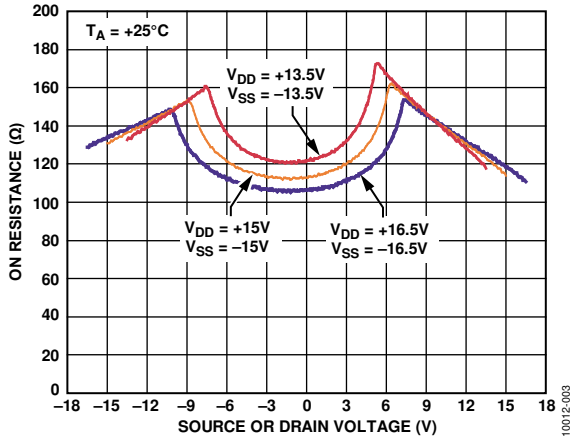

Figure 3. On Resistance as a Function of V_D (V_S) for Dual Supply

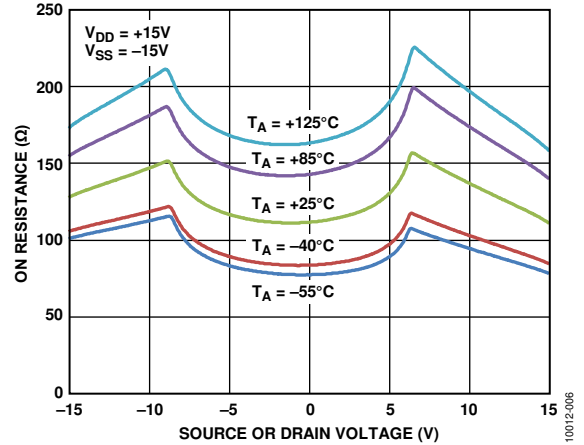

Figure 6. On Resistance as a Function of V_D (V_S) for Different Temperatures, Dual Supply

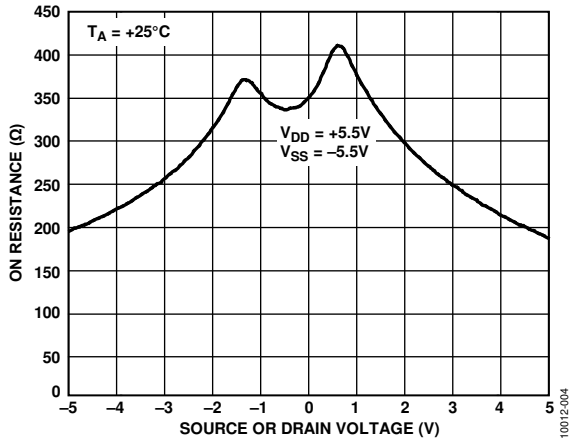

Figure 4. On Resistance as a Function of V_D (V_S) for Dual Supply

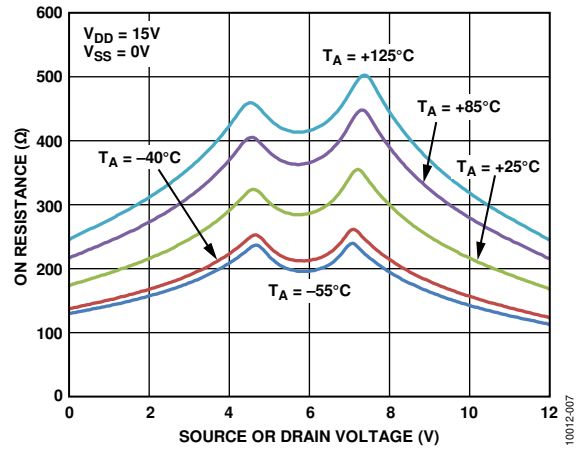

Figure 7. On Resistance as a Function of V_D (V_S) for Different Temperatures, Single Supply

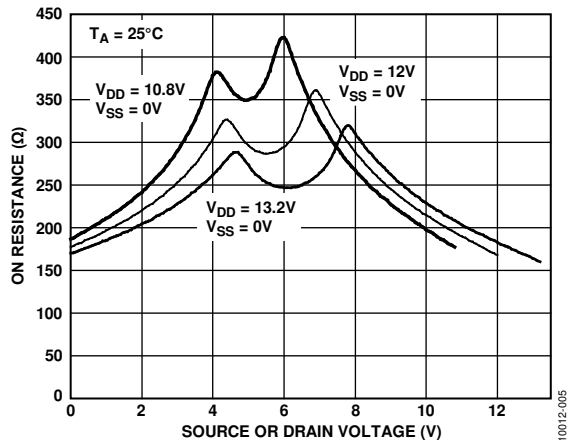

Figure 5. On Resistance as a Function of V_D (V_S) for Single Supply

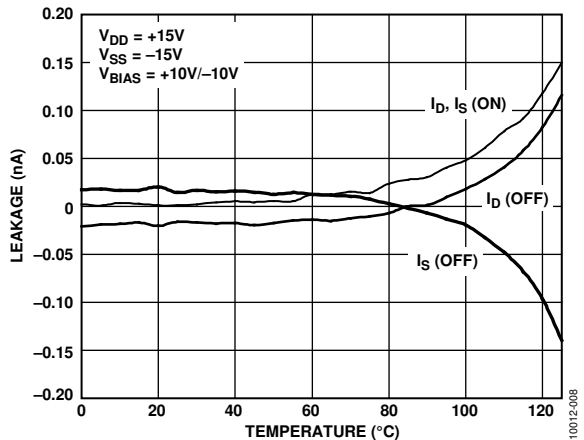

Figure 8. Leakage Currents as a Function of Temperature, Dual Supply

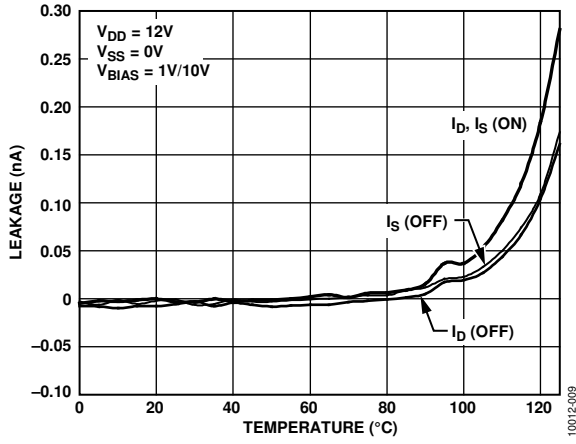

Figure 9. Leakage Currents as a Function of Temperature, Single Supply

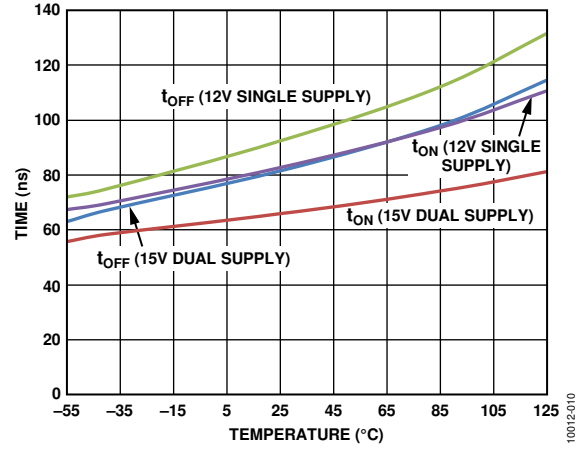

Figure 10. t_{ON}/t_{OFF} Times vs. Temperature

TEST CIRCUITS

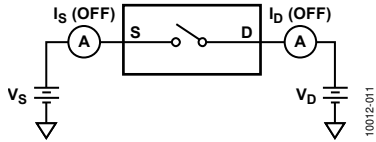

Figure 11. Off Leakage

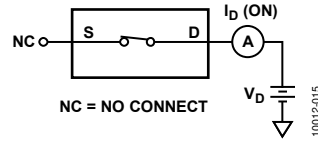

Figure 15. On Resistance

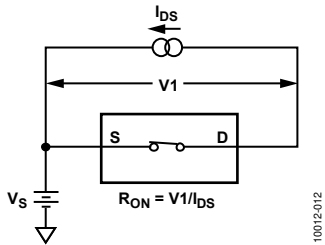

Figure 12. On Leakage

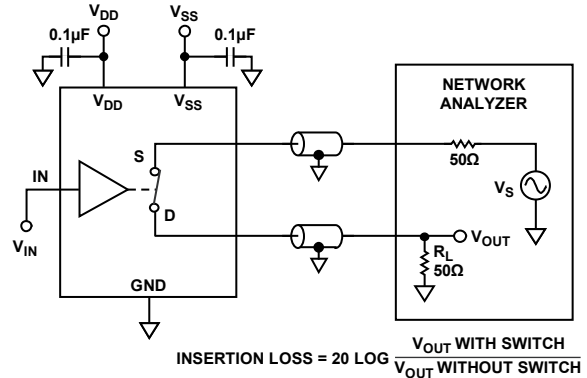

Figure 16. Bandwidth

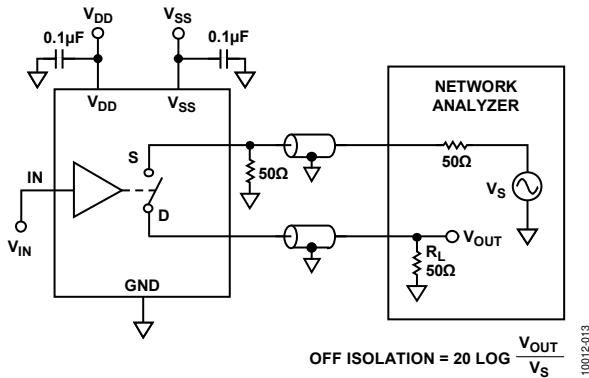

Figure 13. Off Isolation

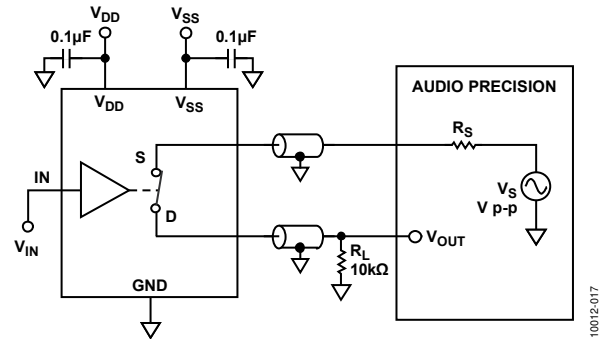

Figure 17. THD + Noise

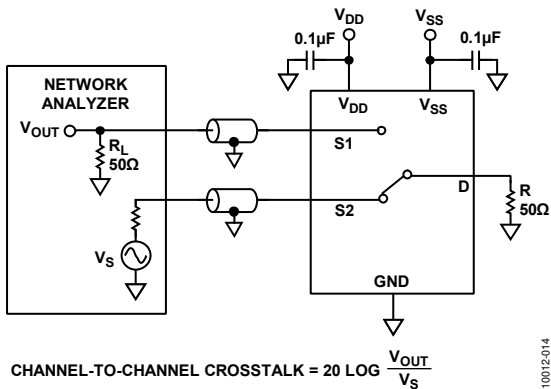

Figure 14. Channel-to-Channel Crosstalk

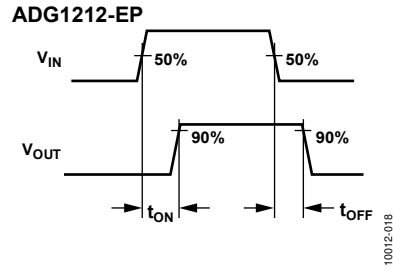
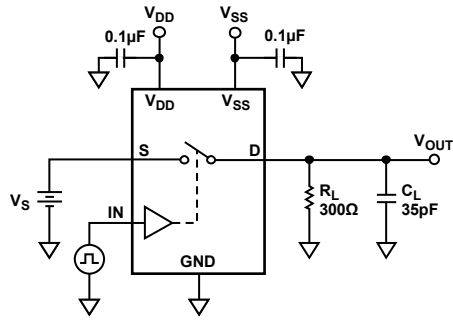

Figure 18. Switching Times

10012-018

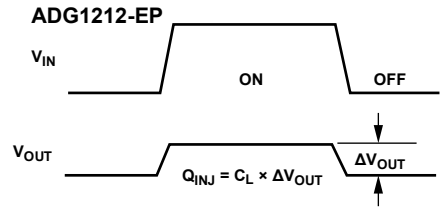
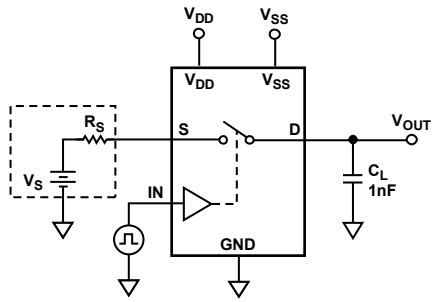
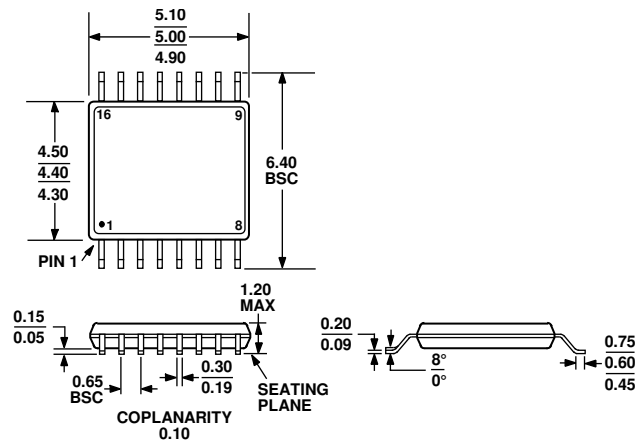

Figure 19. Charge Injection

10012-019

OUTLINE DIMENSIONS



COMPLIANT TO JEDEC STANDARDS MO-153-AB

Figure 20. 16-Lead Thin Shrink Small Outline Package [TSSOP]
(RU-16)
Dimensions shown in millimeters

ORDERING GUIDE

Model ¹	Temperature Range	Package Description	Package Option
ADG1212SRU-EP-RL7	-55°C to +125°C	16-Lead Thin Shrink Small Outline Package [TSSOP]	RU-16
ADG1212SRUZ-EP-RL7	-55°C to +125°C	16-Lead Thin Shrink Small Outline Package [TSSOP]	RU-16

¹ Z = RoHS Compliant Part

NOTES