

TOLERANCE UNLESS OTHERWISE SPECIFIED	
.X	±0.25
.XX	±0.15
.XXX	±0.10

THIS IS A C.A.D. GENERATED DRAWING
DO NOT MAKE MANUAL REVISIONS TO MASTER.
UNLESS OTHERWISE SPECIFIED, ALL RADIUS ARE 0.2 MM.



ISSUE NUMBER

ORIGINAL

1

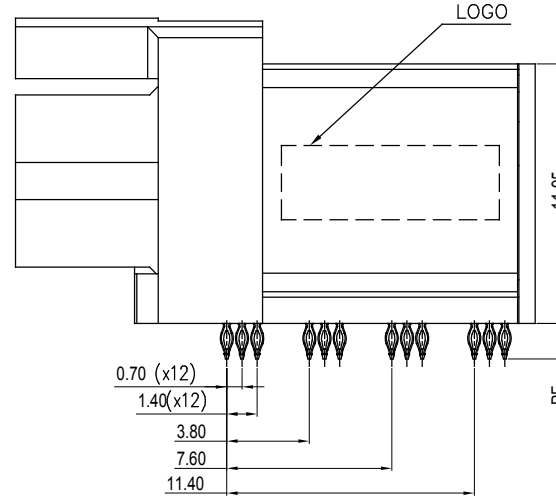
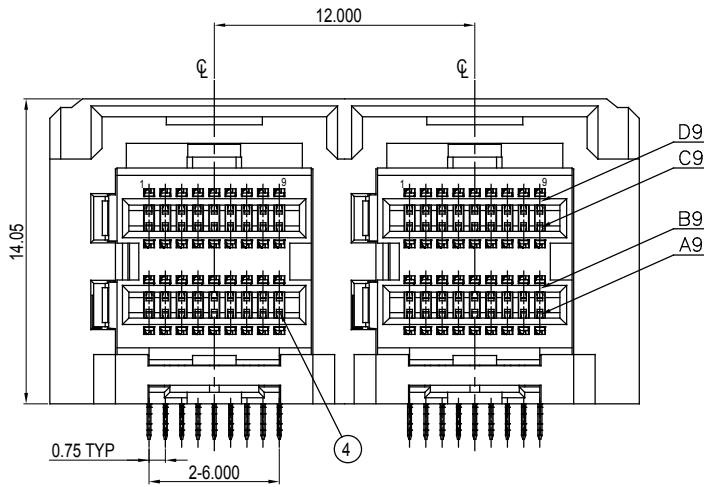

NOTES:

MATERIAL:

HOUSING:

CONTACT:

COLOR:

L.C.P HIGH TEMPERATURE GLASS,
UL-94V-0
COPPER ALLOY
GOLD FLASH PLATING ON CONTACT AREA
MATTE TIN PLATING ON SOLDER TAIL OVER
NICKEL UNDER PLATING
BLACK

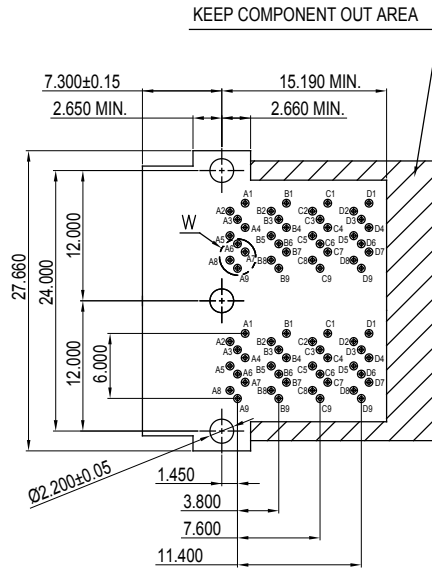

RECOMMENDED PCB LAYOUT (TOP VIEW)
TOLERANCE=±0.05mm

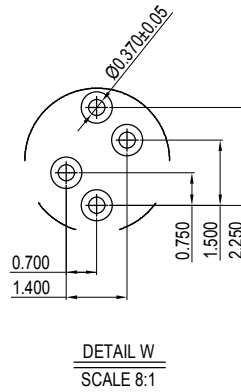

DETAIL W
SCALE 8:1

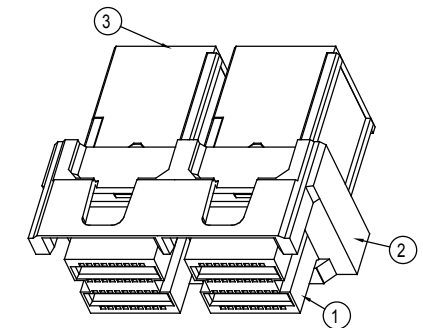
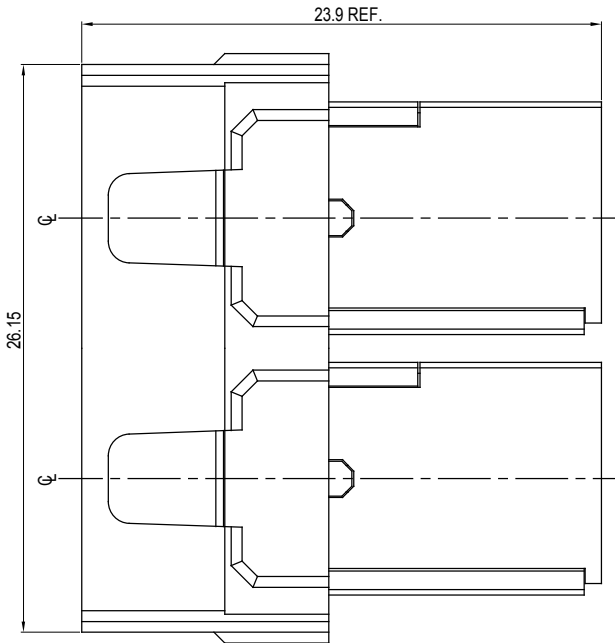

MINI SAS HD INTERNAL, RIGHT ANGLE PRESS FIT,
72 CONTACTS, FEMALE



EDAC INC
TORONTO, ONTARIO
CANADA
YOUR CONNECTION TO QUALITY & SERVICE

THESE DRAWINGS AND SPECIFICATIONS
ARE THE PROPERTY OF EDAC INC., AND
SHALL NOT BE REPRODUCED, OR COPIED
OR USED AS THE BASIS FOR THE
MANUFACTURE OR SALE OF APPARATUS
WITHOUT WRITTEN PERMISSION.

ACAD REFERENCE NO.: 902-072-225-002

DRAWN: W.T

DATE: JULY.03 /2018

CHECKED:

DATE:

SCALE: N.T.S

SHEET 1 OF 1

DRAWING NUMBER: 902-072-225-002

ISSUE

PART NUMBER: 902-072-225-002

1



THIS SERIES FULLY CONFORMS TO
THE EUROPEAN UNION DIRECTIVES
2011/65/EU FOR RoHS COMPLIANCY.