

THIS DRAWING IS UNPUBLISHED. RELEASED FOR PUBLICATION ,19 .
 © COPYRIGHT 19 BY AMP INCORPORATED. ALL RIGHTS RESERVED.

LOC	DIST	REVISIONS					
		P	LTR	DESCRIPTION	DATE	DWN	APVD
G	14		J	REDRAWN PER 0720-0377-94	10OCT94	LO	ME

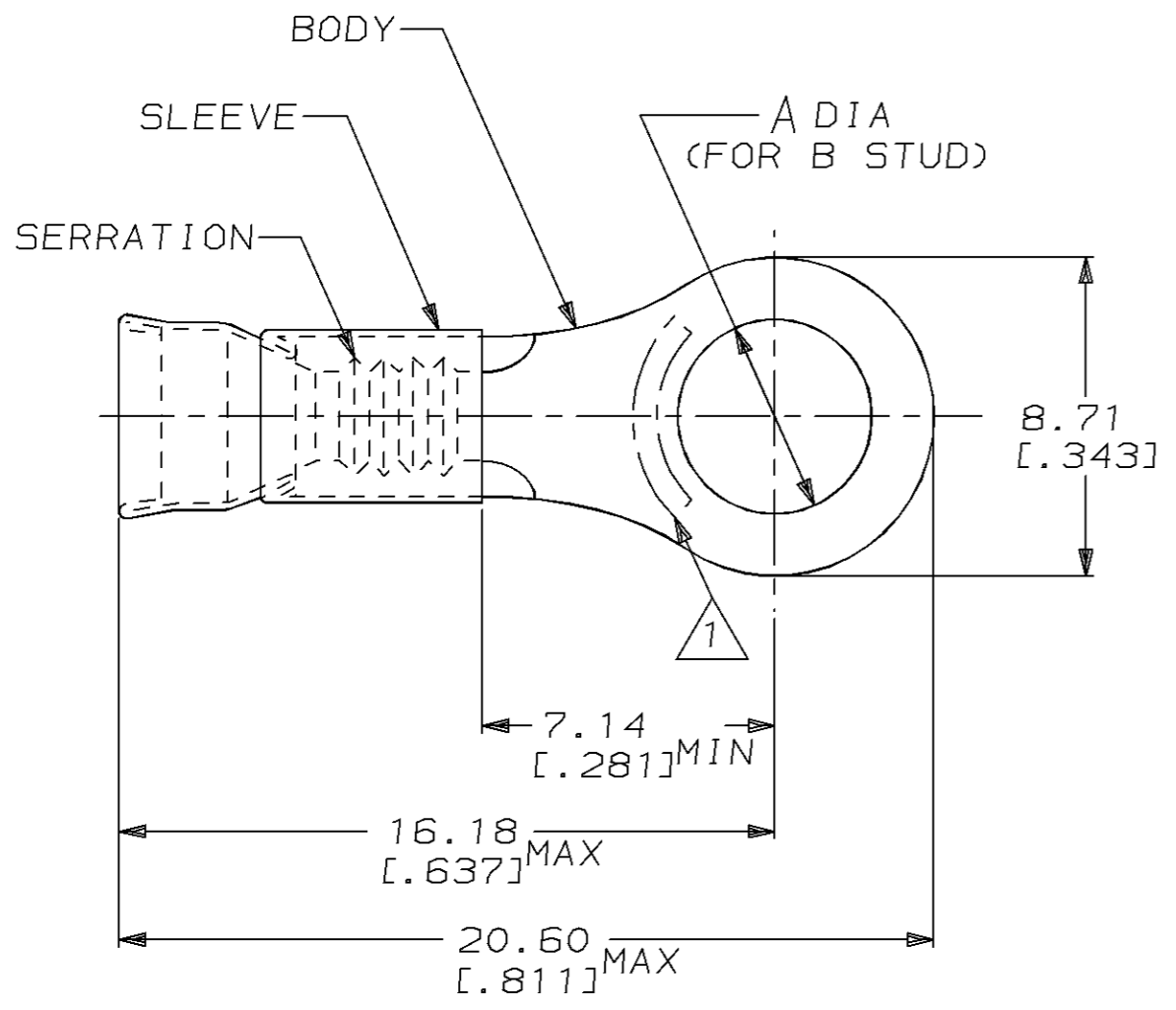

△ SEE TABLE FOR STAMPING

- 2. WIRE INSUL DIA, 3.05-4.32 [.120-.170]
- 3. TONGUE MATL THK, 0.79±0.05 [.031±.002]

AMP 16-14	4.34 ±0.08 [.171±.003]	#8	NICKEL PER ASTM B162	ORANGE	5000	ON TAPE, REEL	1-322337-2
AMP 16-14CH	5.00 ±0.08 [.197±.003]	#10	CHROMEL	GRAY	500	LOOSE PIECE	1-322337-1
AMP 16-14CH	4.34 ±0.08 [.171±.003]	#8	CHROMEL	GRAY	500	LOOSE PIECE	1-322337-0
AMP 16-14	4.34 ±0.08 [.171±.003]	#8	NICKEL PER ASTM B162	ORANGE	1000	LOOSE PIECE	322337
STAMPING	A	B	BODY MATERIAL	SLV COLOR	QTY	PACKAGE TYPE	PART NO

AMP INCORPORATED
 CUSTOMER SERVICE SYSTEM

FOR ADDITIONAL PRODUCT INFORMATION OR COPIES OF DRAWINGS AND TECHNICAL DOCUMENTS
 PRODUCT INFORMATION CENTER
 1-800-522-6752

FOR APPLICATION TOOLING INFORMATION
 TOOLING ASSISTANCE CENTER
 1-800-722-1111

FOR ORDER ENTRY
 1-800-526-5142

MAX RECOMMENDED OPERATING TEMPERATURE:
 649°C [1200°F]

VOLTAGE RATING:
 -

CIRCULAR MIL AREA:
 1.04mm² - 2.62mm² [2050-5180]

STRANDED WIRE

THIS DRAWING IS A CONTROLLED DOCUMENT FOR AMP INCORPORATED. IT IS SUBJECT TO CHANGE AND THE CONTROLLING ENGINEERING ORGANIZATION SHOULD BE CONTACTED FOR THE LATEST REVISION.

DIMENSIONS:
 mm [in]

TOLERANCES UNLESS OTHERWISE SPECIFIED:

0 PLC	±-
1 PLC	±-
2 PLC	±0.20 [.008]
3 PLC	±-
4 PLC	±-
ANGLES	±-

MATERIAL BODY, SEE TABLE
 SLEEVE, NI SIL PER ASTM B122

FINISH SLV COLOR, SEE TABLE

DWN L OLMEDA 10OCT94
 CHK M ELLIS 10OCT94
 APVD S BORTNER 10OCT94

AMP Incorporated
 Harrisburg, PA 17105-3608

NAME TERMINAL, RING TONGUE, STRATOTHERM, DIAMOND GRIP, WIRE SIZE, 16-14 AWG

SIZE A3 CAGE CODE 00779 DRAWING NO C-322337

WEIGHT -

CUSTOMER DRAWING SCALE 6:1 SHEET 1 OF 1 REV J