

THESE DRAWINGS ARE THE PROPERTY OF QUALTEK ELECTRONICS AND NOT TO BE REPRODUCED FOR OR COMMUNICATED TO A THIRD PARTY WITHOUT THE EXPRESS WRITTEN PERMISSION OF AN OFFICER OF QUALTEK ELECTRONICS.

REVISION			
REV.	DESCRIPTION	DATE	APPROVED
B	RoHS Compliancy	06-01-06	DP

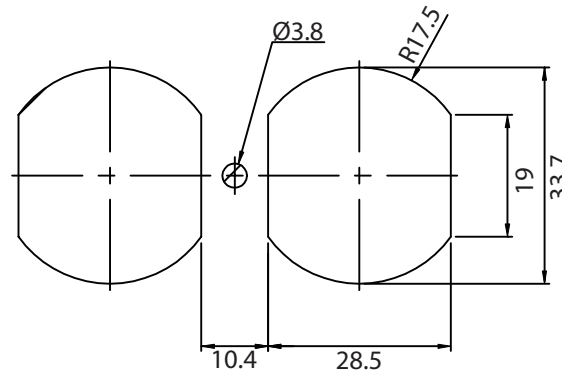

PANEL CUTOUT

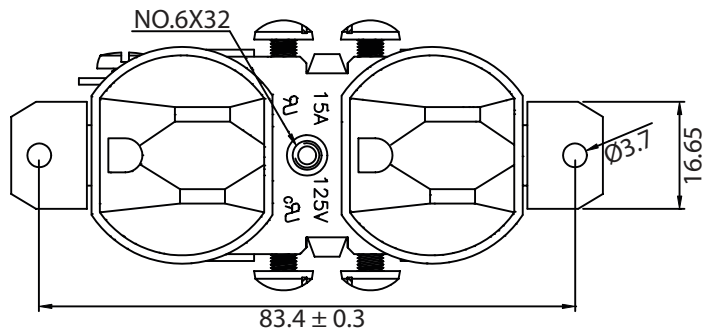
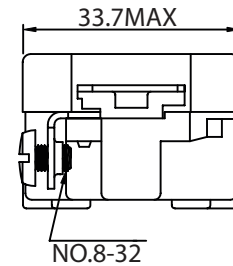
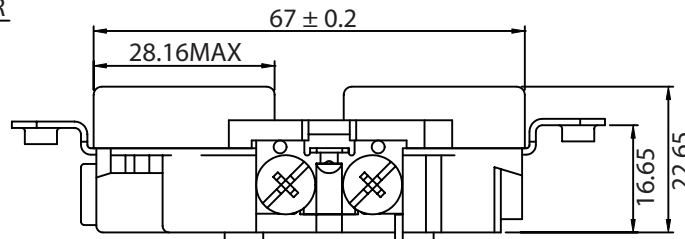
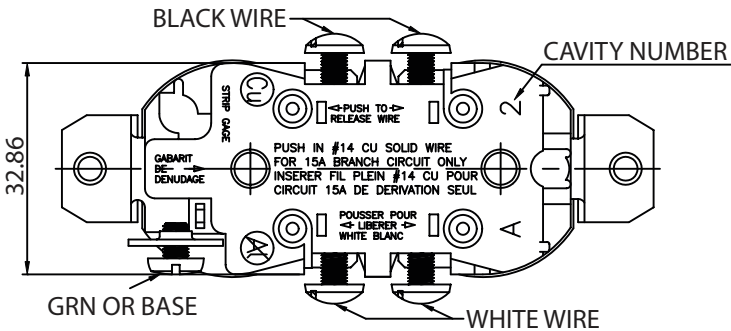
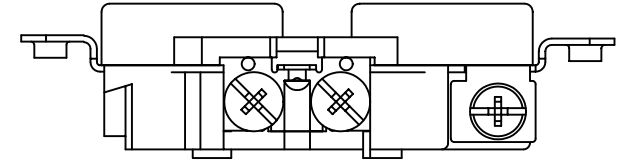

**CONTROLLED**

NOTES:

- USE SOLID COPPER WIRE ONLY
- RATING: 15A 125V
- STRAP-W/OUT PLASTER EARS, NO MTG.SCR.
- SIDE WIRE TERMINAL #14 AWG.
- MOLD GATE MARKS PERMISSIBLE
- TERMINAL SCREWS-IN ARE OPTIONAL
- COMBINATION HEAD SCREWS ARE OPTIONAL
- APPROVALS: UL,cUL
- RoHS COMPLIANT

Dim range (mm)		Tolerance +/- (mm)	Qualtek Electronics Corp. PPC DIVISION		
0-1		0.15	Part Number: 740W-H/01		RoHS Compliant
1-6		0.20	Description: AC RECEPTACLE		
6-18		0.30	UNIT: mm		REV. B
18-50		0.50	Drawn / Date	Checked / Date	Approved / Date
50-120		0.70	B.Zhang	09-04-02	JJH / 09-04-02
120-250		0.90	09-04-02	09-04-02	
250-500		1.20			