

THIS DRAWING IS UNPUBLISHED. RELEASED FOR PUBLICATION  
 © COPYRIGHT BY TYCO ELECTRONICS CORPORATION. ALL RIGHTS RESERVED.

LOC	DIST	REVISIONS					
G	86	P	LTR	DESCRIPTION	DATE	DWN	APVD
		A		REL PER ECR 05-008795	16AUG05	JR	MS

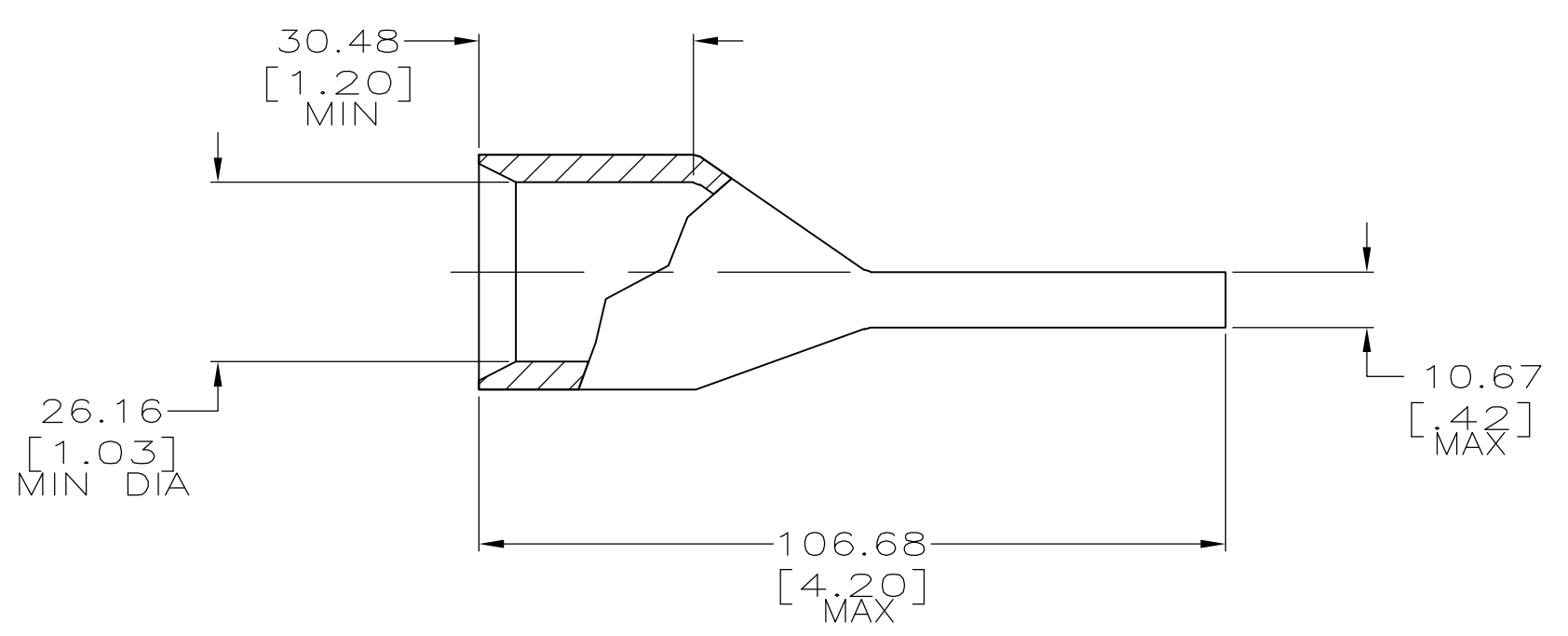
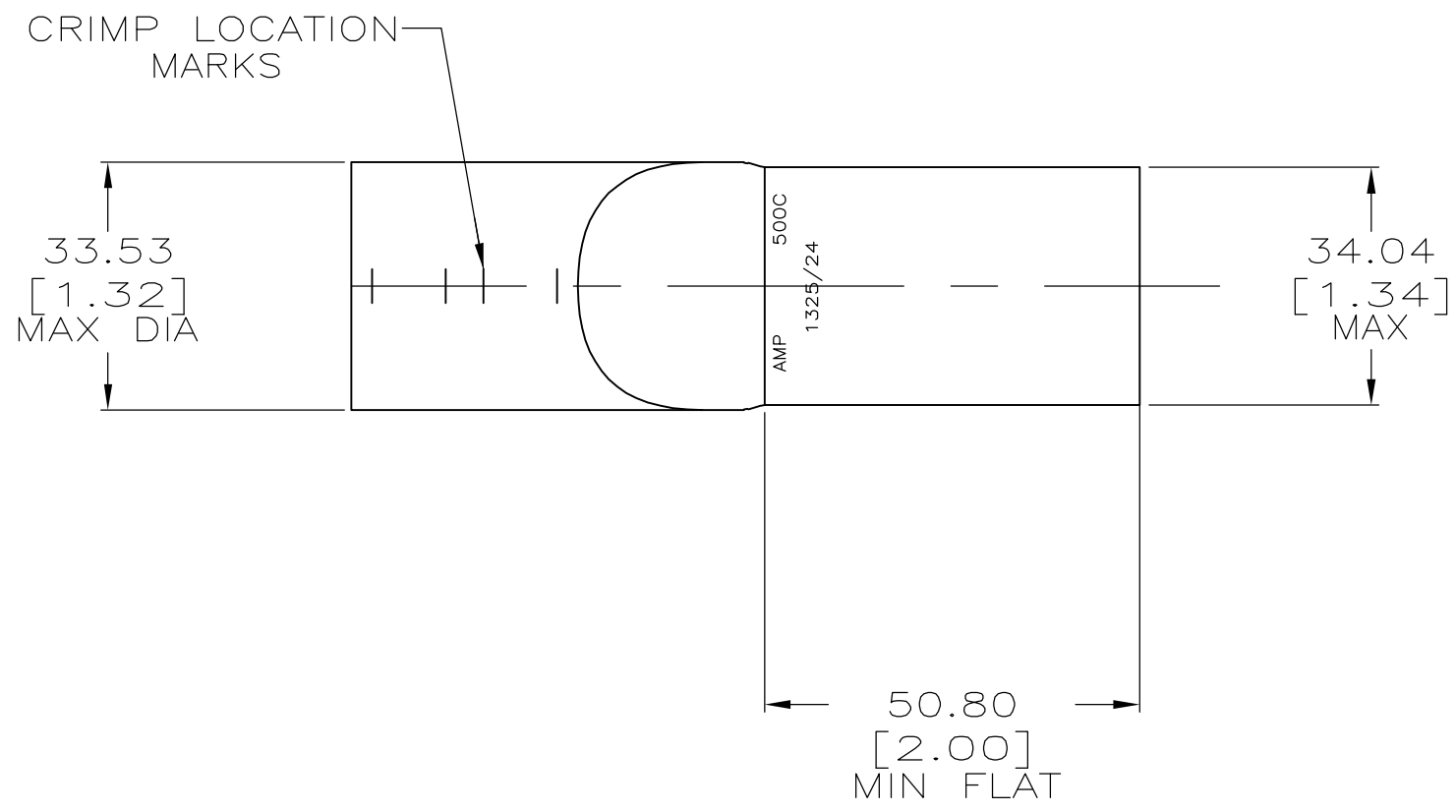

- ① TIN PL 0.00381[.000150] MIN THK PER ASTM B-545
- ② CRIMP DIES: USE P/N 46756-2 (600 MCM)
- ③ COPPER PER ASTM B-75, ANNEALED

696781-1  
 PART NO.

THIS DRAWING IS A CONTROLLED DOCUMENT.		DWN JR RUTH 01APR05	Tyco Electronics Corporation Harrisburg, Pa 17105-3608	
DIMENSIONS: INCHES		CHK MJ SPICER 01APR05		
TOLERANCES UNLESS OTHERWISE SPECIFIED:		APVD MJ SPICER 01APR05	NAME TERMINAL, CENTER LINE TONGUE, AMPOWER, WIRE SIZE: 500 HD MCM	
0 PLC ± - 1 PLC ± - 2 PLC ± 0.51[.020] 3 PLC ± - 4 PLC ± - ANGLES ± - FINISH - ①		PRODUCT SPEC -	SIZE A2	CAGE CODE 00779
MATERIAL - ③		APPLICATION SPEC -	DRAWING NO C=696781	RESTRICTED TO -
CUSTOMER DRAWING			SCALE 1:1	SHEET 1 OF 1

696781