

PART NUMBER	REVISION	DESCRIPTION	FEED TYPE
2151431-1	E	FINE CRIMP HEIGHT ADJUST	MECHANICAL
2151431-2	E	FINE CRIMP HEIGHT ADJUST	PNEUMATIC
7-2151431-1	E	MECHANICAL AND CRIMP TOOLING KIT	MECHANICAL
7-2151431-2	E	PNEUMATIC AND CRIMP TOOLING KIT	PNEUMATIC
7-2151431-7	A	CRIMP TOOLING KIT	-

ATLANTIC VERSION TERMINATOR INTERFACE ADAPTER

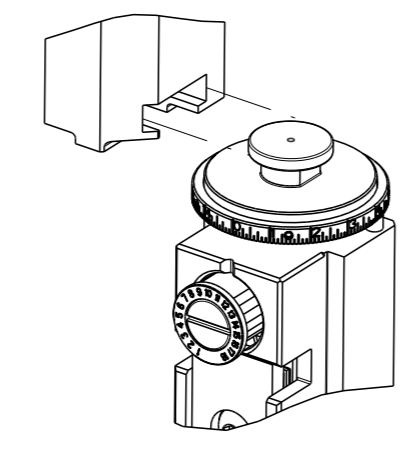

APPLICATOR DATA		
CRIMP	SIZE	TYPE
WIRE	2.01 mm [.079]	F
INSUL	2.82 mm [.111]	F

APPLICATOR INSTRUCTIONS
408-35042

TERMINAL DATA: MOLEX TERMINAL		MOLEX CRIMP SPECIFICATION	
TERMINAL NAME: PIN AND SOCKET TERMINAL			
WIRE STRIP LENGTH	INSULATION DIAMETER RANGE		
3.18-3.96 mm [.125-.156 IN]	Ø1.52-3.05 mm [.060-.120 IN]		
TERMINAL APPLICATION SPECIFICATION			
TERMINALS APPLIED			
TE TERMINAL	MOLEX TERMINAL	TE TERMINAL	MOLEX TERMINAL
1572015-7	02-06-1101	1572015-1	02-06-2101
1572015-8	02-06-5101	1572015-2	02-06-6101
1572015-9	02-06-5108	1572015-3	02-06-6118
1-1572015-0	02-06-5100	1572015-4	02-06-6116
1-1572015-1	02-06-5105	1572015-5	02-06-6100
1-1572015-2	02-06-1118	1572015-6	02-06-6105
1-1572015-3	02-06-2201		

WIRE SIZE	CRIMP HEIGHT mm [INCH]	CRIMP HEIGHT REFERENCE SETTING
18 AWG	1.055+/-0.015 [.0415+/- .0005]	5.9
20 AWG	0.99+/-0.03 [.039+/- .001]	6.3
22 AWG	0.935+/-0.025 [.037+/- .001]	6.8
24 AWG	0.885+/-0.025 [.035+/- .001]	7.1

- 1. RECOMMENDED SPARE PARTS
- 2. REFER TO SUPPLIED INSTRUCTION SHEET FOR CLEANING, LUBRICATION AND STORAGE OF APPLICATOR.
- 3. APPLY PART NUMBER 2-23419-6 LOCTITE TO THREADS OF ITEM 242.
- 4. CRIMP HEIGHT REFERENCE SETTING WAS THE SETTING USED WHEN THE APPLICATOR WAS QUALIFIED AT THE FACTORY. ADJUSTMENT MAY BE NECESSARY WHEN RUNNING APPLICATOR IN THE FIELD.
- 5. CUT TO LENGTH AT ASSEMBLY.
- 6. UNLESS SPECIFIED OTHERWISE TORQUE VALUES SHALL BE USED PER DOCUMENT, 101-35000.

LOC	DIST	REVISIONS					
		P	LY#	DESCRIPTION	DATE	OWN	APVD
A	66	B		ECR-17-016817	15NOV2017	FL	GB
		C		ECR-18-006851	03MAY2018	TB	JDG
		D		ECR-19-006071	15APR2019	RK	TE
		E		ECR-20-006519	07MAY2020	JWC	GB

1	-	1	1	1	2280441-1	INSERT, SHEAR	282
	-	1	-	-	2119640-1	PUSH ROD, AIR FEED	250
	-	1	-	-	2079988-1	BUSHING, LCH5-12, MISUMI	249
	-	1	-	-	2119641-1	FEED CAM, AIR FEED	248
	-	1	1	1	2119082-9	CAM, SNAIL, INSULATION ADJUSTMENT	244
	-	1	1	1	2079764-1	WASHER, WAVE SPRING, CREST-TO-CREST	243
3	-	1	1	1	2119083-1	RETAINER, INSULATION DIAL	242
	-	2	2	2	7-18023-7	SCR, SKT HD CAP M3 X 4.0	241
	-	-	1	-	2119580-1	MECHANICAL FEED ASSEMBLY	239
	-	1	-	-	2063440-1	AIR FEED MODULE	238
	-	2	-	-	21045-3	RING, RETAIN, EXTERN, 3/16 CRESCENT	172
	-	REF	REF	REF	994970-2	COUNTER, MAGNETIC	164
	-	1	-	-	240638-1	SPRING, FEED FINGER	163
	-	1	-	-	3-23627-7	PIN, RETAIN, GRVD, 3/16 X .854	137
	-	1	-	-	2119799-1	HOLDER, FEED FINGER, AF	136
	-	2	2	2	1-18028-2	WASHER, FLAT, REG M4	119
	-	1	1	1	2844908-1	SCREW, LOCKING	99
	-	1	1	1	2844907-1	POST, LOCKING	98
	-	1	1	1	455888-8	SPACER, CRIMPER	82
	-	1	1	1	240641-9	SPACER	81
	-	1	1	1	1803607-1	DOCUMENTATION PACKAGE	71
	-	1	1	1	2119791-5	DEPRESSOR, WIRE	70
	-	1	1	1	2119943-1	WASHER, SPACER	69
	-	1	1	1	2119740-1	TAG, IDENTIFICATION	67
	-	2	2	2	2168078-1	SCREW, DRIVE, RH, RoHS, 2 x .188	66
	-	1	1	1	2168083-2	SCR, SKT HD CAP, RoHS, M4 X 8.0	60
	-	1	1	1	5-18022-5	SCR, HEX HD CAP, M4 X 6.0	59
	-	1	1	1	1338685-1	PAWL, FEED	56
	-	4	4	4	2168083-3	SCR, SKT HD CAP, RoHS, M4 X 12.0	54
	-	2	2	2	2-2168083-6	SCR, SKT HD CAP, RoHS, M4 X 18	53
	-	1	2	1	18023-9	SCR, SKT HD CAP M4 X 6.0	49
	-	-	1	-	2119652-1	FEED CAM, PRE FEED	48
	-	-	1	-	2119653-1	FEED CAM, POST FEED	47
	-	1	1	1	1803583-9	APPLICATOR BASIC ASSEMBLY, SF	46
	-	1	1	1	1803515-1	RAM ASSEMBLY, SF ATLANTIC	44
	-	1	1	1	1803602-1	SCR, BHSC, RoHS (M8 X 25)	41
	-	2	2	2	2079383-5	SCR, BHSC, RoHS (M4 X 20)	33
	-	2	2	2	2-2844962-6	SPACER, CYLINDRICAL, STRIP GUIDE	30
	-	1	1	1	2844992-1	ASSEMBLY, STRIP GUIDE	29
	-	1	1	1	1-455888-0	SPACER, CRIMPER	28
	-	1	1	1	1320928-2	STRIP GUIDE	24
	-	1	1	1	2168083-2	SCR, SKT HD CAP, RoHS, M4 X 8.0	21
	-	1	1	1	1-18028-2	WASHER, FLAT, REG M4	20
	-	1	1	1	2119533-1	STRIPPER, SIDE FEED	19
	-	1	1	1	1-690518-2	HOLD DOWN, TERMINAL	18
1	-	1	1	1	690463-6	FLOATING SHEAR, REAR	17
5	-	2	2	2	1-2168083-1	SCR, SKT HD CAP, RoHS, M3 X 6	16
	-	1	1	1	690691-4	PLATE, REAR SHEAR	15
1	-	1	1	1	2119862-1	SHEAR HOLDER, REAR	14
1	-	1	1	1	2119806-1	INSERT, SHEAR	13
	-	2	2	2	3-22280-3	SPRING, COMPRESSION	12
	-	2	2	2	1-356885-4	STOP, SHEAR	11
1	-	1	1	1	2119805-1	SHEAR HOLDER, FRONT	10
1	-	1	1	1	1803095-1	FLOATING SHEAR, FRONT	9
1	1	2	2	1	1633620-4	ANVIL, COMBINATION	8
	-	1	1	1	240641-2	SPACER	7
	-	1	1	1	690468-1	DEPRESSOR SHEAR, REAR	6
	-	1	1	1	2119757-8	DEPRESSOR, SHEAR	5
	-	1	1	1	1-238011-6	BLOCK, CRIMPER SPACER	4
1	1	2	2	1	1803016-5	CRIMPER, INSULATION F	3
	-	1	1	1	455888-4	SPACER, CRIMPER	2
1	1	2	2	1	7-1633305-8	CRIMPER, WIRE PREMIUM	1

***WARNING**
 ON INSTALLATION, SET WIRE DISC TO CRIMP HEIGHT REFERENCE SETTING FOR LARGEST WIRE SIZE. CRIMP HEIGHT REFERENCE SETTINGS GREATER THAN THE VALUE SHOWN MAY CAUSE DAMAGE TO THE CRIMP TOOLING. REFER TO THE INSTRUCTION SHEET FOR PROPER SETUP AND ADJUSTMENTS.

ATLANTIC VERSION
 Shown on sheets 1 of 4 & 2 of 4
 (Pacific version shown on sheets 3 of 4 & 4 of 4)

DIMENSIONS:		TOLERANCES UNLESS OTHERWISE SPECIFIED:		MATERIAL:	
mm	0 PLC ±	1 PLC ±	2 PLC ±	3 PLC ±	4 PLC ±
	ANGLES	FINISH			

OWN	J. HUANG	14MAY2012	
CHK			
APVD	S. YI	14MAY2012	
PRODUCT SPEC			
APPLICATION SPEC			
WEIGHT			
CAGE CODE	00779	DRAWING NO	2151431
RESTRICTED TO			
Customer Accessible Production Drawing	SCALE	1:2	SHEET 1 OF 4

LOC	DIST	REVISIONS			
A	66	REV	DATE	OWN	APVD
-	-	SEE SHEET 1	-	-	-

FEED TYPE MECHANICAL

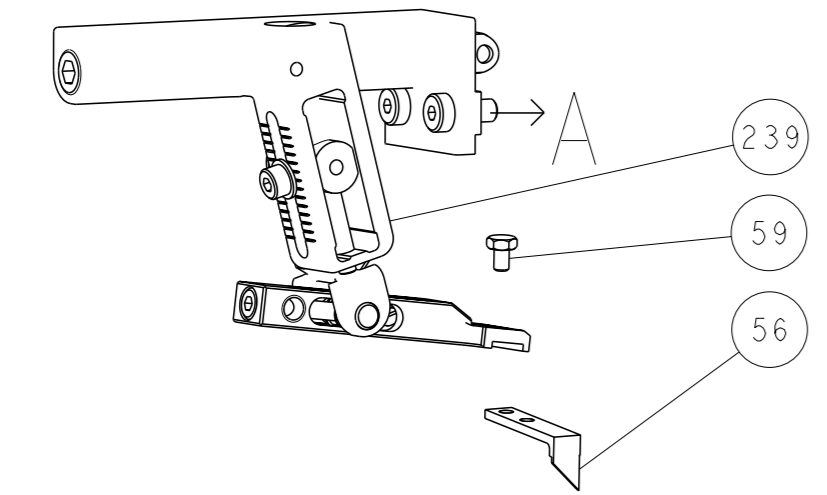

PNEUMATIC

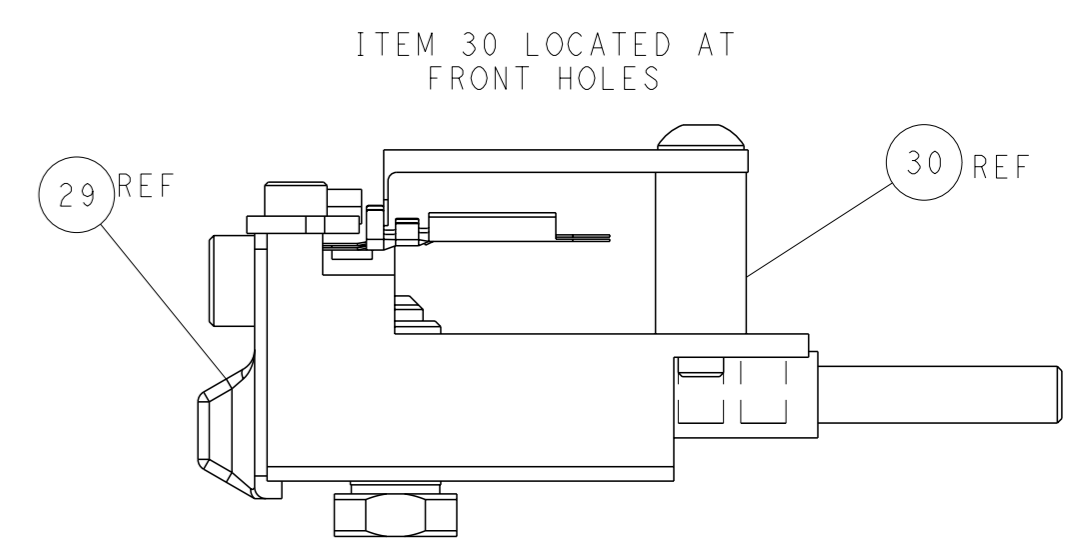
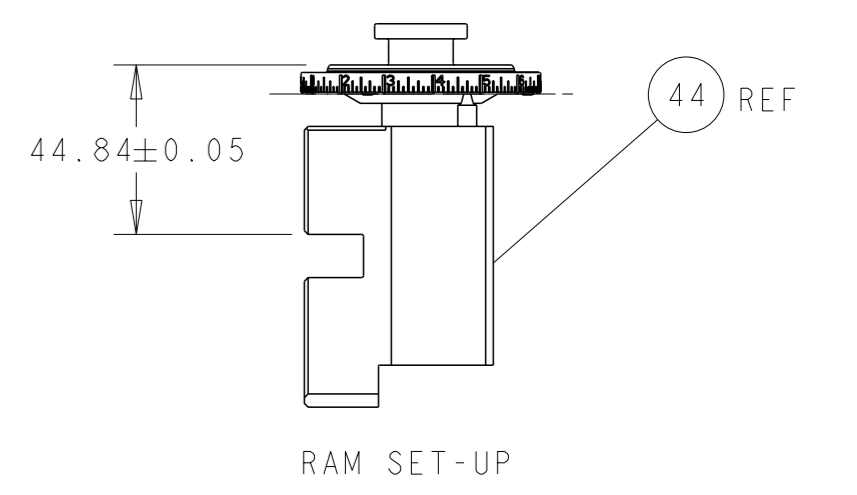
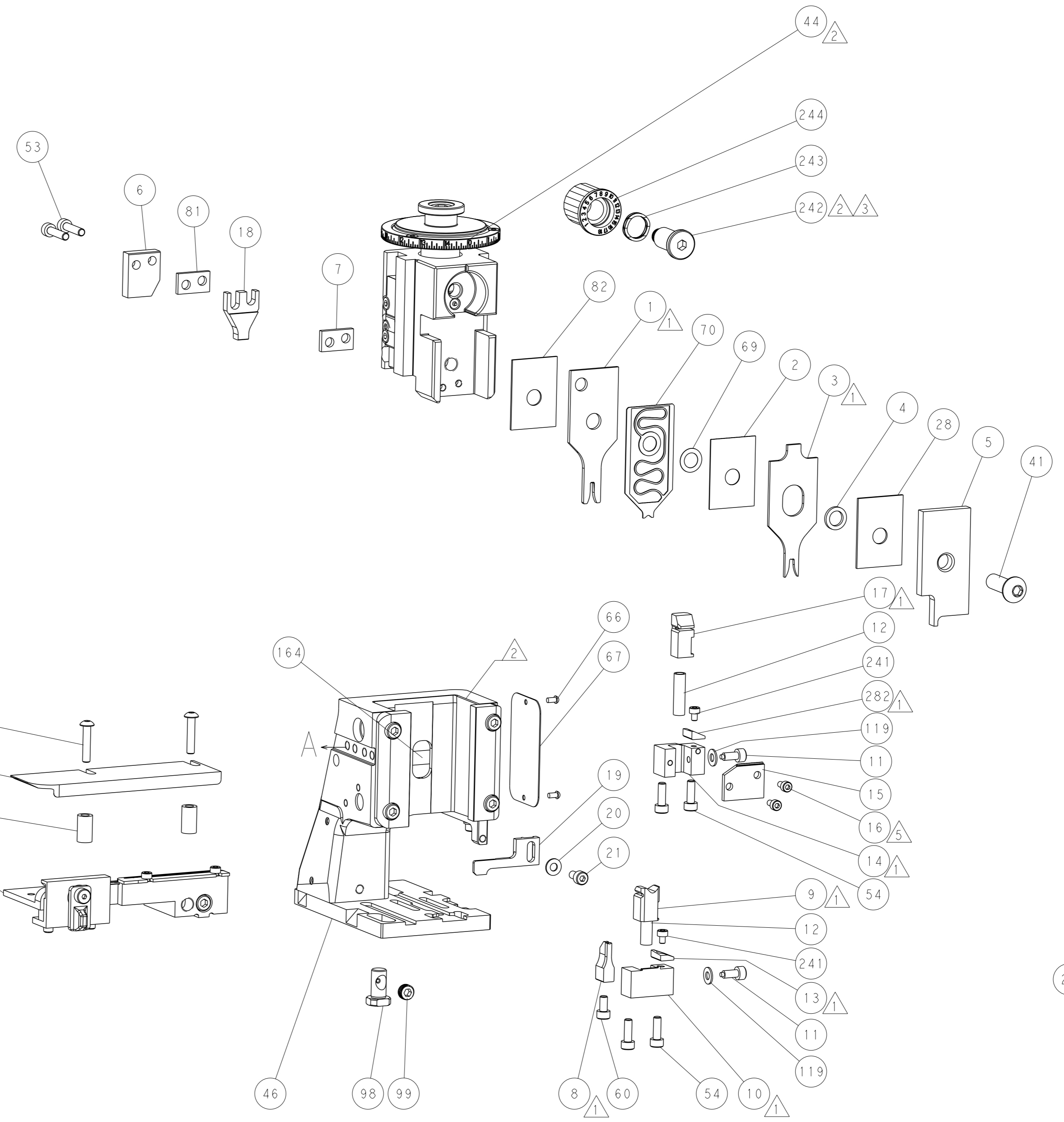
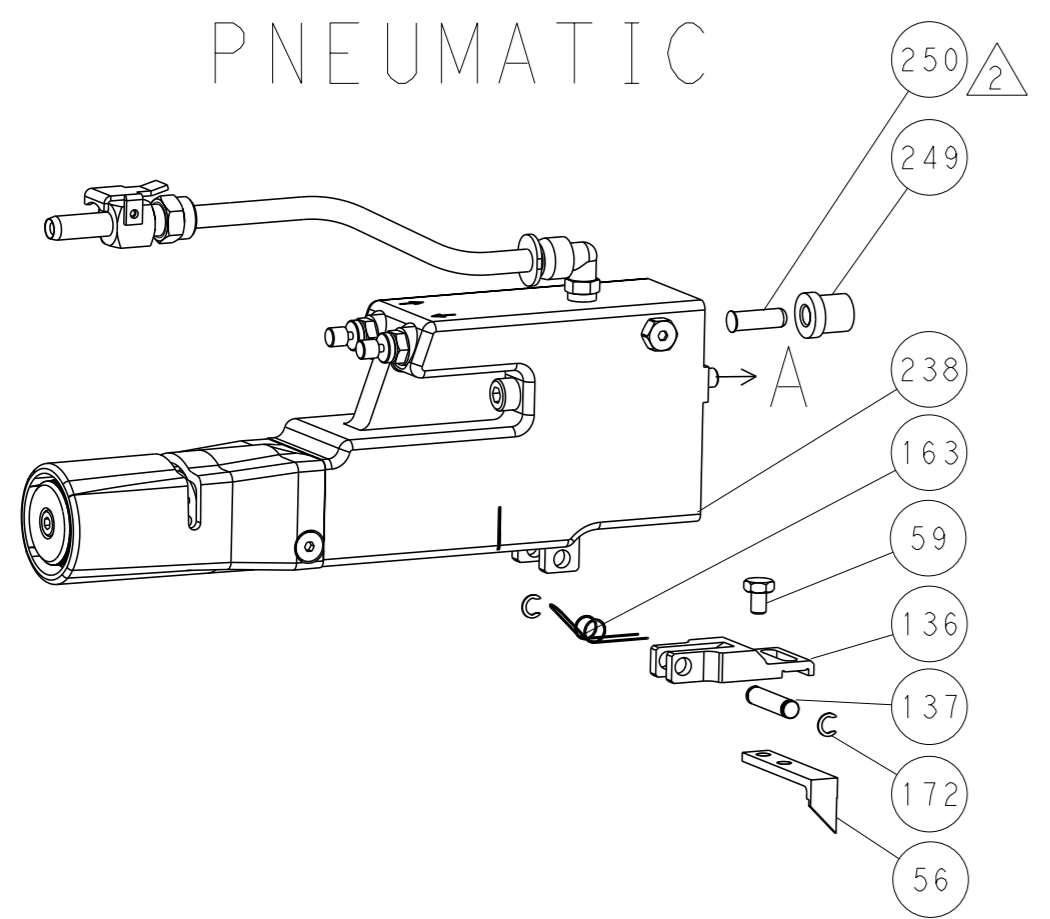

CAM POSITIONS

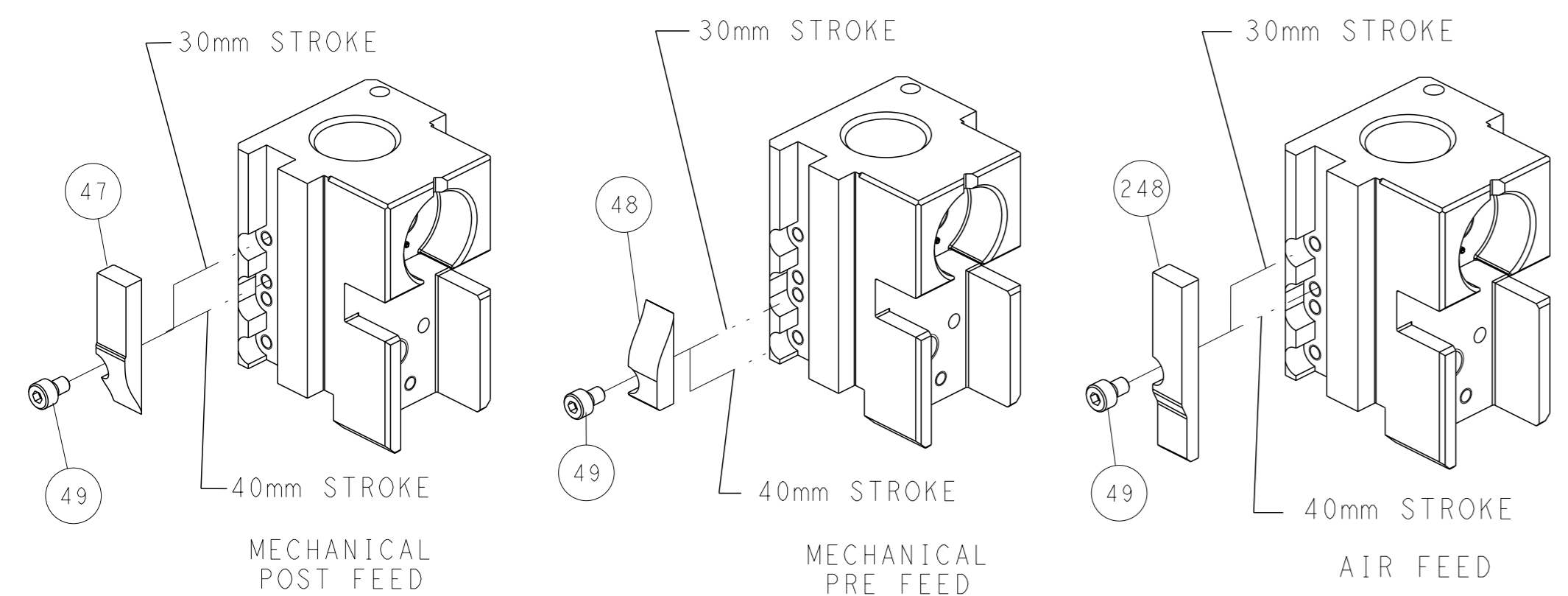

ATLANTIC VERSION
 Shown on sheets 1 of 4 & 2 of 4
 (Pacific version shown on sheets 3 of 4 & 4 of 4)

<small>THIS DRAWING IS UNPUBLISHED. RELEASED FOR PUBLICATION. IT IS SUBJECT TO CHANGE AND THE CONTROLING ENGINEERING ORGANIZATION SHOULD BE CONTACTED FOR THE LATEST REVISION.</small>		OWN: H. HUANG CHK: S. XI APVD: S. XI DATE: 14MAY2012	NAME: Ocean Side Feed Applicator SIZE: A1 CAGE CODE: 00779 DRAWING NO: 2151431	TE Connectivity Harrisburg, PA 17105-3608
DIMENSIONS: mm TOLERANCES UNLESS OTHERWISE SPECIFIED: 0 PLC ± 1 PLC ± 2 PLC ± 3 PLC ± 4 PLC ± ANGLES FINISH ±	WEIGHT: - SCALE: 1:2 SHEET: 2 of 4 REV: E	Customer Accessible Production Drawing		

PART NUMBER	REVISION	DESCRIPTION	FEED TYPE
2-2151431-1	E	FINE CRIMP HEIGHT ADJUST	MECHANICAL
2-2151431-2	E	FINE CRIMP HEIGHT ADJUST	PNEUMATIC
7-2151431-7	A	CRIMP TOOLING KIT	-

PACIFIC VERSION TERMINATOR
INTERFACE ADAPTER

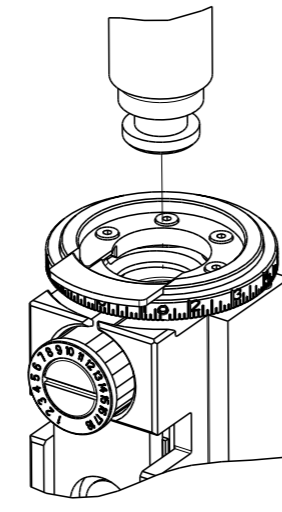

APPLICATOR DATA		
CRIMP	SIZE	TYPE
WIRE	2.01 mm [.079]	F
INSUL	2.82 mm [.111]	F
APPLICATOR INSTRUCTIONS 408-35042		

TERMINAL DATA: MOLEX TERMINAL MOLEX CRIMP SPECIFICATION

WIRE STRIP LENGTH	INSULATION DIAMETER RANGE
3.18-3.96 mm [.125-.156 IN]	Ø1.52-3.05 mm [.060-.120 IN]

TERMINAL APPLICATION SPECIFICATION	MLX #011182017 Rev -
------------------------------------	----------------------

TERMINALS APPLIED

TE TERMINAL	MOLEX TERMINAL	TE TERMINAL	MOLEX TERMINAL
1572015-7	02-06-1101	1572015-1	02-06-2101
1572015-8	02-06-5101	1572015-2	02-06-6101
1572015-9	02-06-5108	1572015-3	02-06-6118
1-1572015-0	02-06-5100	1572015-4	02-06-6116
1-1572015-1	02-06-5105	1572015-5	02-06-6100
1-1572015-2	02-06-1118	1572015-6	02-06-6105
1-1572015-3	02-06-2201		

WIRE SIZE	CRIMP HEIGHT mm [INCH]	CRIMP HEIGHT REFERENCE SETTING
18 AWG	1.055+/-0.015 [.0415+/-0.0005]	5.9
20 AWG	0.99+/-0.03 [.039+/-0.001]	6.3
22 AWG	0.935+/-0.025 [.037+/-0.001]	6.8
24 AWG	0.885+/-0.025 [.035+/-0.001]	7.1

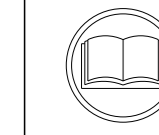

- 1 RECOMMENDED SPARE PARTS
- 2 REFER TO SUPPLIED INSTRUCTION SHEET FOR CLEANING, LUBRICATION AND STORAGE OF APPLICATOR.
- 3 APPLY PART NUMBER 2-23419-6 LOCTITE TO THREADS OF ITEM 242.
- 4 CRIMP HEIGHT REFERENCE SETTING WAS THE SETTING USED WHEN THE APPLICATOR WAS QUALIFIED AT THE FACTORY. ADJUSTMENT MAY BE NECESSARY WHEN RUNNING APPLICATOR IN THE FIELD.
- 5 CUT TO LENGTH AT ASSEMBLY.
- 6. UNLESS SPECIFIED OTHERWISE TORQUE VALUES SHALL BE USED PER DOCUMENT, 101-35000.

***WARNING**
ON INSTALLATION, SET WIRE DISC TO CRIMP HEIGHT REFERENCE SETTING FOR LARGEST WIRE SIZE. CRIMP HEIGHT REFERENCE SETTINGS GREATER THAN THE VALUE SHOWN MAY CAUSE DAMAGE TO THE CRIMP TOOLING. REFER TO THE INSTRUCTION SHEET FOR PROPER SETUP AND ADJUSTMENTS.

LOC	DIST	REV	DESCRIPTION	DATE	OWN	APVD
A	66	-	SEE SHEET 1	-	-	-

1	1	2280441-1	INSERT, SHEAR	282
-	1	2119640-1	PUSH ROD, AIR FEED	250
-	1	2079988-1	BUSHING, LCH5-12, MISUMI	249
-	1	2119082-9	CAM, SNAIL, INSULATION ADJUSTMENT	244
-	1	2079764-1	WASHER, WAVE SPRING, CREST-TO-CREST	243
3	1	2119083-1	RETAINER, INSULATION DIAL	242
-	2	7-18023-7	SCR, SKT HD CAP M3 X 4.0	241
-	-	2119580-1	MECHANICAL FEED ASSEMBLY	239
-	1	2063440-1	AIR FEED MODULE	238
-	2	21045-3	RING, RETAIN, EXTERN, 3/16 CRESCENT	172
-	REF	994970-2	COUNTER, MAGNETIC	164
-	1	240638-1	SPRING, FEED FINGER	163
-	1	2119641-2	FEED CAM, AIR FEED	151
-	1	2168083-8	SCR, SKT HD CAP, RoHS, M4 X 16	144
-	4	2168083-9	SCR, SKT HD CAP, RoHS, M4 X 20	143
-	-	2119653-2	FEED CAM, POST FEED	142
-	1	1-1803583-0	APPLICATOR BASIC ASSEMBLY, SF	141
-	1	1803516-1	RAM ASSEMBLY, SF PACIFIC	140
-	1	3-23627-7	PIN, RETAIN, GRVD, 3/16 X .854	137
-	1	2119799-1	HOLDER, FEED FINGER, AF	136
-	2	1-18028-2	WASHER, FLAT, REG M4	119
-	1	2844908-1	SCREW, LOCKING	99
-	1	2844907-1	POST, LOCKING	98
-	1	455888-8	SPACER, CRIMPER	82
-	1	240641-9	SPACER	81
-	1	1803607-1	DOCUMENTATION PACKAGE	71
-	1	2119791-5	DEPRESSOR, WIRE	70
-	1	2119943-1	WASHER, SPACER	69
-	1	2119740-1	TAG, IDENTIFICATION	67
-	2	2168078-1	SCREW, DRIVE, RH, RoHS, 2 x .188	66
-	1	5-18022-5	SCR, HEX HD CAP, M4 X 6.0	59
-	1	1338685-1	PAWL, FEED	56
-	2	2-2168083-6	SCR, SKT HD CAP, RoHS, M4 X 18	53
-	1	18023-9	SCR, SKT HD CAP M4 X 6.0	49
-	-	2119652-1	FEED CAM, PRE FEED	48
-	1	1803602-1	SCR, BHSC, RoHS (M8 X 25)	41
-	2	2079383-5	SCR, BHSC, RoHS (M4 X 20)	33
-	2	2-2844962-6	SPACER, CYLINDRICAL, STRIP GUIDE	30
-	1	2844992-1	ASSEMBLY, STRIP GUIDE	29
-	1	1-455888-0	SPACER, CRIMPER	28
-	1	1320928-2	STRIP GUIDE	24
-	1	2168083-2	SCR, SKT HD CAP, RoHS, M4 X 8.0	21
-	1	1-18028-2	WASHER, FLAT, REG M4	20
-	1	2119533-1	STRIPPER, SIDE FEED	19
-	1	1-690518-2	HOLD DOWN, TERMINAL	18
1	1	690463-6	FLOATING SHEAR, REAR	17
5	2	1-2168083-1	SCR, SKT HD CAP, RoHS, M3 X 6	16
-	1	690691-4	PLATE, REAR SHEAR	15
1	1	2119862-1	SHEAR HOLDER, REAR	14
1	1	2119806-1	INSERT, SHEAR	13
-	2	3-22280-3	SPRING, COMPRESSION	12
-	2	1-356885-4	STOP, SHEAR	11
-	1	2119805-1	SHEAR HOLDER, FRONT	10
1	1	1803095-1	FLOATING SHEAR, FRONT	9
1	1	1633620-4	ANVIL, COMBINATION	8
-	1	240641-2	SPACER	7
-	1	690468-1	DEPRESSOR SHEAR, REAR	6
-	1	2119757-8	DEPRESSOR, SHEAR	5
-	1	1-238011-6	BLOCK, CRIMPER SPACER	4
1	1	1803016-5	CRIMPER, INSULATION F	3
-	1	455888-4	SPACER, CRIMPER	2
1	1	7-1633305-8	CRIMPER, WIRE PREMIUM	1

PACIFIC VERSION
Shown on sheets 3 of 4 & 4 of 4
(Atlantic version shown on sheets 1 of 4 & 2 of 4)

DIMENSIONS: mm		TOLERANCES UNLESS OTHERWISE SPECIFIED:		OWN: H. HUANG 14MAY2012		NAME: TE Connectivity Harrisburg, PA 17105-3608	
0 PLC ±		1 PLC ±		APVD: S. XI 14MAY2012		PRODUCT SPEC	
2 PLC ±		3 PLC ±		APPLICATION SPEC		SIZE: A1	
4 PLC ±		FINISH: *		WEIGHT: -		CAGE CODE: 00779	
MATERIAL: -		FINISH: -		DRAWING NO: 2151431		RESTRICTED TO: -	
Customer Accessible Production Drawing				SCALE: 1:2		SHEET 3 OF 4	

