

THIS DRAWING IS UNPUBLISHED.

RELEASED FOR PUBLICATION

20

© COPYRIGHT 20 BY -

ALL RIGHTS RESERVED.

LOC HQ DIST 00

REVISIONS

P	LTR	DESCRIPTION	DATE	DWN	APVD
	HI	REVISED PER ECO-11-005027	12MAR2011	RK	HMR

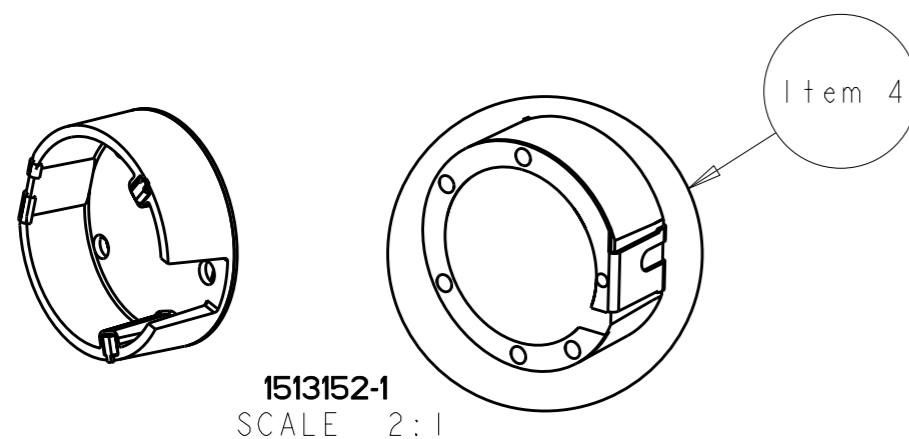
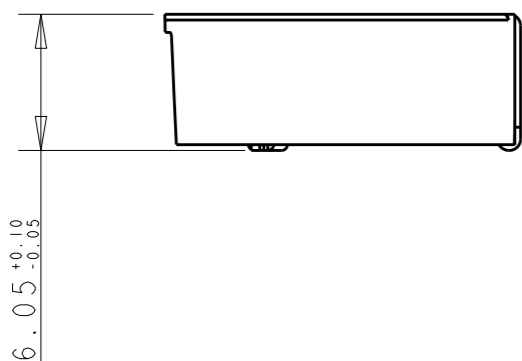
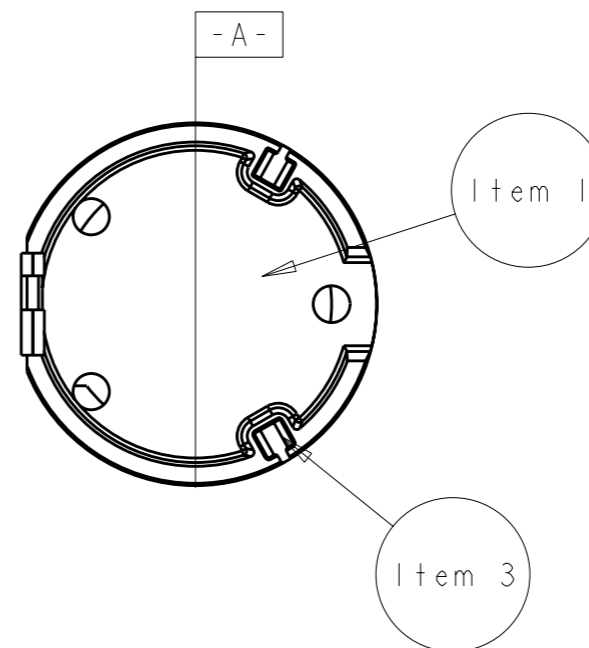
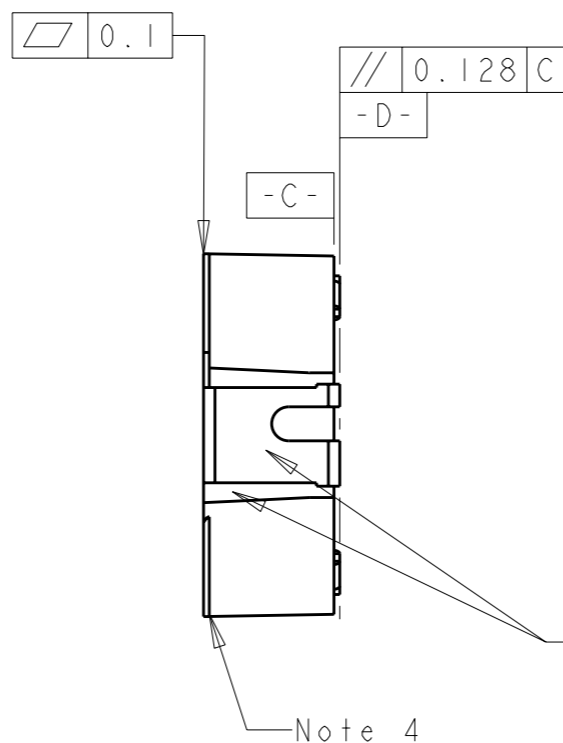
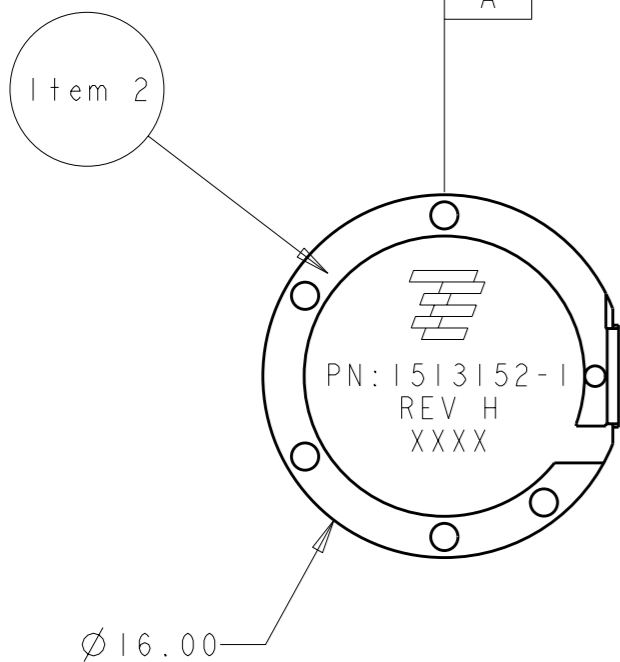

NOTES:

1. Material-Dow Questra WA550, 30% glass filled, natural color.
2. Item 2 insert molded into item 1. Flat side wall of Item 2 to be flush with flat side wall in Item 1.
3. Item 3 press fit into item 4.
4. No air gaps between components.
5. General tolerance block applies unless otherwise specified.
6. Part will be identified with part number, rev letter, TE logo and 4 digit date code. 1st two digits for the year and the 2nd two digits for the week.

ITEM NO.	QTY.	DESCRIPTION
1	1	OVERMOLDED METAL RING
2	1	METAL RING
3	2	ANCHOR TAB
4	1	ASSEMBLY

THIS DRAWING IS A CONTROLLED DOCUMENT.		DWN DJL 11JAN2005	 TE Connectivity	
DIMENSIONS: mm		CHK -		
TOLERANCES UNLESS OTHERWISE SPECIFIED:		APVD -	NAME Antenna GPS Assembly 1513152-1	
0 PLC ±0.10	1 PLC ±0.10	PRODUCT SPEC -	SIZE A3 CAGE CODE 00779 DRAWING NO. C-1513152 RESTRICTED TO -	
2 PLC ±0.05	3 PLC ±0.05	APPLICATION SPEC -	SCALE 4:1 SHEET 1 OF 1 REV HI	
4 PLC ±0.01	ANGLES ±1°	WEIGHT -	CUSTOMER DRAWING	
MATERIAL -	FINISH -			