

THIS DRAWING IS UNPUBLISHED. RELEASED FOR PUBLICATION ,19 .
 © COPYRIGHT 19 BY AMP INCORPORATED. ALL INTERNATIONAL RIGHTS RESERVED.

| LOC | DIST | P | F | ZONE | LTR | DESCRIPTION | DATE | APPD |
|-----|------|---|---|------|-----|--------------------------|---------|--------|
| G | 14 | | | | M | REVISED PER 0720-0867-96 | 27FEB96 | OK SHB |

METRIC
 DIMENSIONS LISTED IN mm [INCHES]

| | |
|--------------------------|---------------------------|
| AMP WIRE RANGE | E13288 Listed |
| 22-16 AWG STRANDED | 22-16 AWG STRANDED |
| LR7189 Certified | MILITARY P/N AND CLASS |
| NOT CERTIFIED | NOT APPLICABLE |

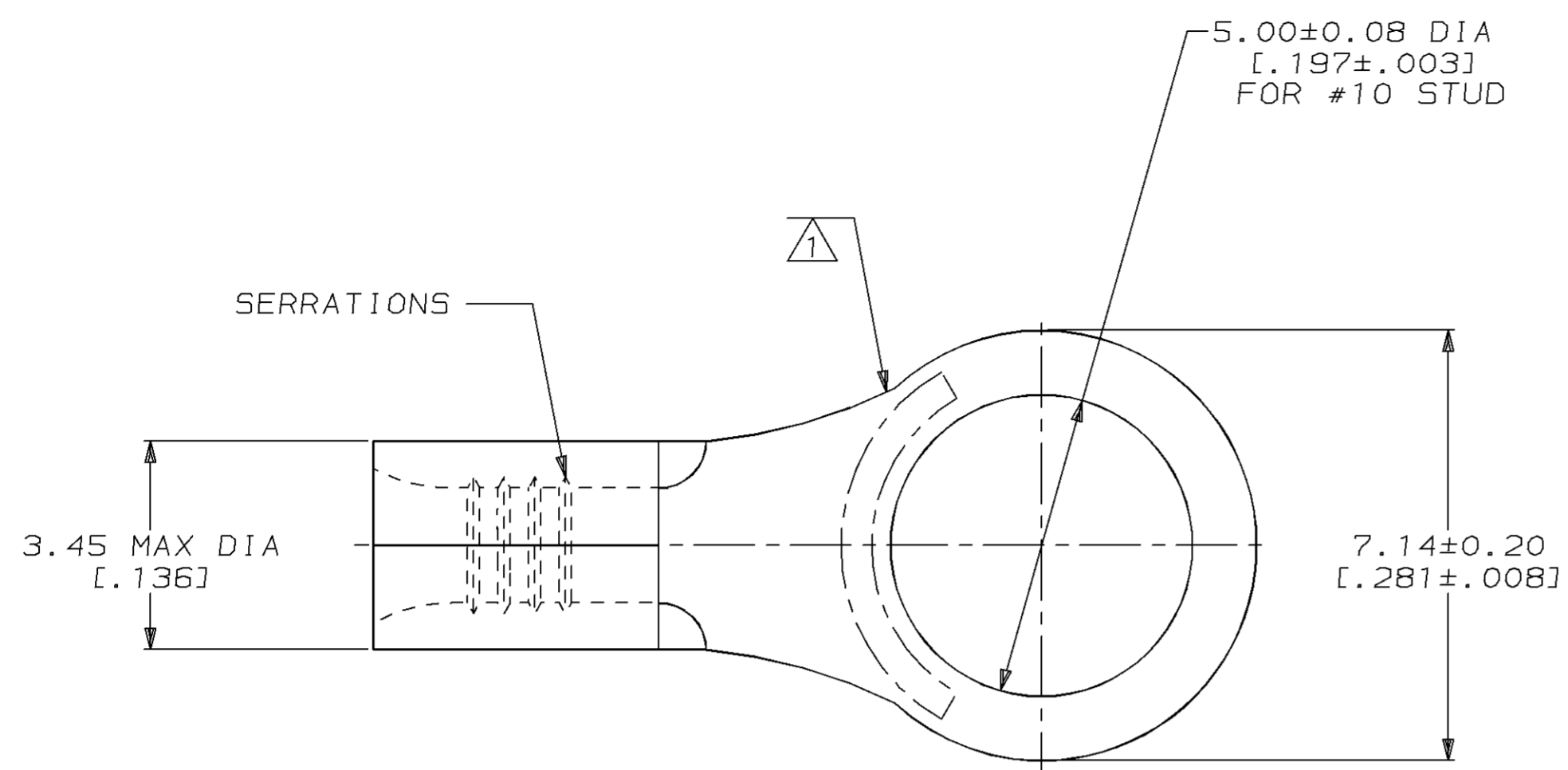

△ STAMP AMP 22-18* APPROX AS SHOWN
 22-16 TERMINALS ARE STAMPED 22-18 IN
 ACCORDANCE WITH MILITARY SPEC MIL-T-7928
 COMMERCIAL WIRE SIZE IS 22-16

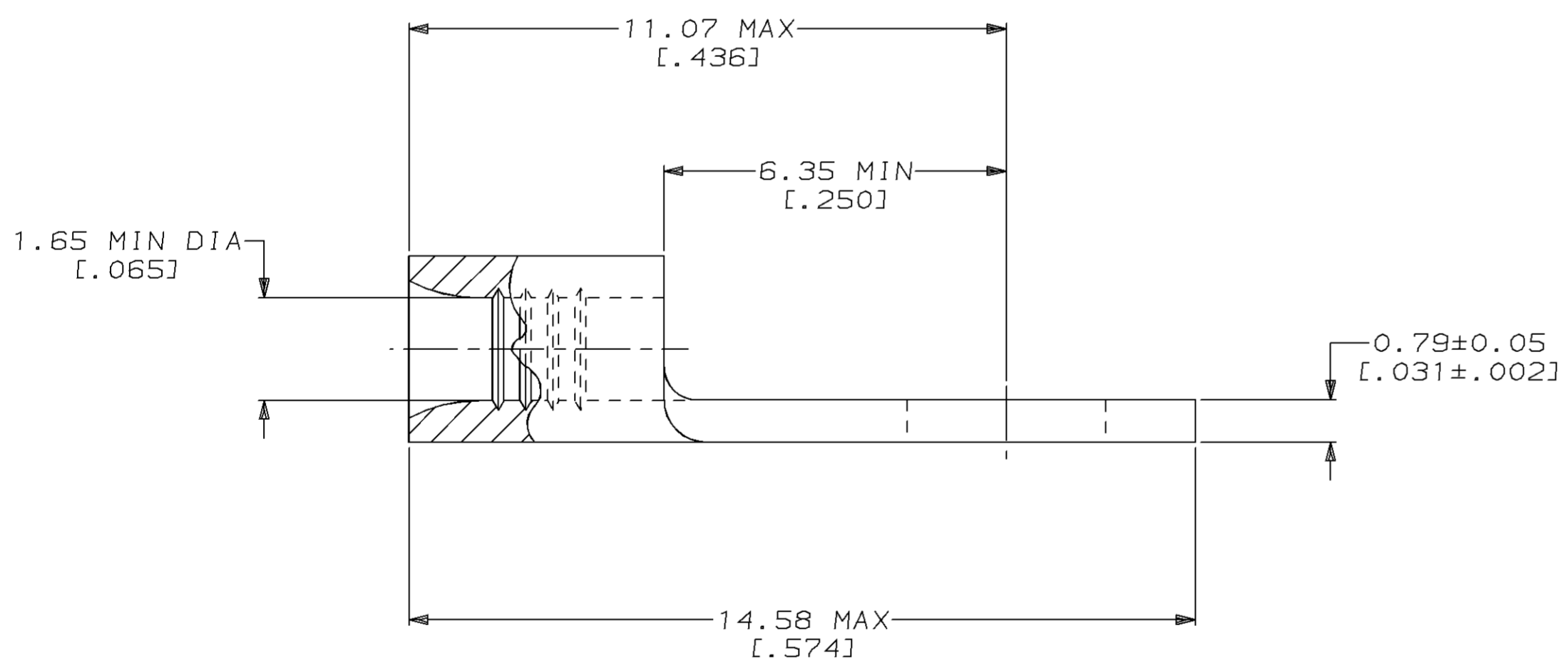

| | | | | | | | | |
|--|--|---|--|----------------------------|---|---------------|--------------------|-----------------------|
| AMP INCORPORATED CUSTOMER SERVICE SYSTEMS | | MAX RECOMMENDED OPERATING TEMPERATURE: 170°C MAX | DO NOT SCALE PRINT. UNLESS SPECIFIED DIMENSIONS IN mm [INCHES] TOLERANCES ON: 2 PLC DEC ± - 3 PLC DEC ± - ANGLES ± - | DR 2-3-93 TA BRINKMAN | 31266 AMP PART NUMBER | | | |
| FOR ADDITIONAL PRODUCT INFORMATION OR COPIES OF DRAWINGS AND TECHNICAL DOCUMENTS | PRODUCT INFORMATION CENTER 1-800-522-6752 | VOLTAGE RATING: NOT APPLICABLE | MATERIAL COPPER PER ASTM B-152 ANNEALED | CHK 2-3-93 DA PATTERSON | AMP Incorporated Harrisburg, PA 17105-3608 | | | |
| FOR APPLICATION TOOLING INFORMATION | TOOLING ASSISTANCE CENTER 1-800-722-1111 | WIRE CROSS SECTIONAL AREA RANGE: 0.26-1.65mm ² [509-3,260] CIR MILS STRANDED | FINISH TIN PLATE 0.00254[.000100] MIN THK PER MIL-T-10727 | APPD 2-3-93 DE MILLER | NAME TERMINAL, RING TONGUE, BUDGET | | | |
| FOR ORDER ENTRY | 1-800-526-5142 | THIS DRAWING IS A CONTROLLED DOCUMENT FOR AMP INCORPORATED. IT IS SUBJECT TO CHANGE AND THE CONTROLLING ENGINEERING ORGANIZATION SHOULD BE CONTACTED FOR THE LATEST REVISION. | | APPD 2-3-93 JL MECKLEY | PRODUCT SPEC - | SIZE C | CAGE CODE 00779 | DRAWING NO G=31266 |
| | | | | APPLICATION SPEC - | WEIGHT - | SCALE 10:1 | | SHEET 1 OF 1 |