

REV.	DESCRIPTION	DATE
A	NEW DRAWING	7/22/2008
B	multiple part updated	7/30/2010
C	mechanical change to the bracket shape	1/23/2012
D	updated drawing	4/27/2018
E	updated drawing	12/15/2022

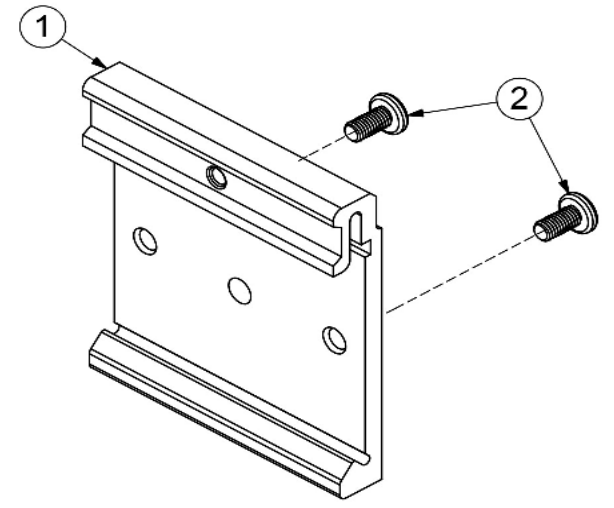

TOLERANCE: ± 0.3 MM

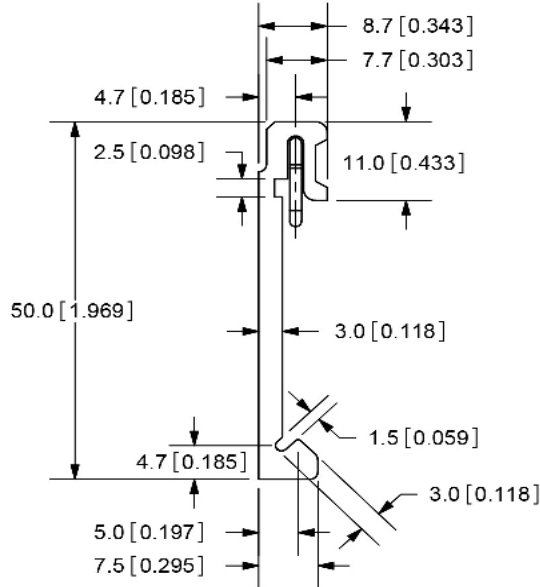
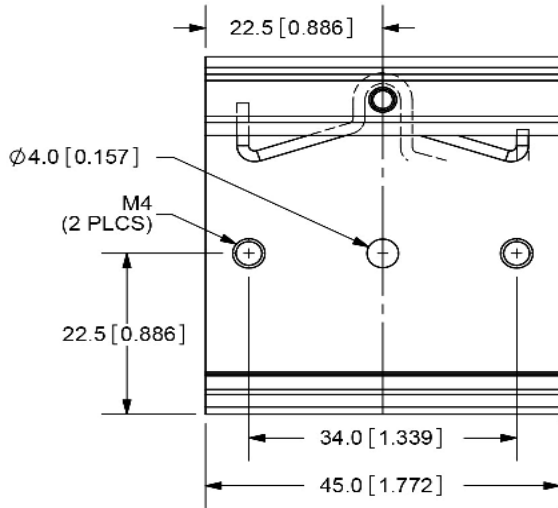

20050 SW 112th Ave.
 Tualatin, OR 97062
 Phone: 503-612-2300
 800-275-4899
 Fax: 503-612-2383
 Website: www.cui.com

TITLE: DIN RAIL MOUNTING BRACKET		REV: A
PART NO. STK-DIN		UNITS: MM [INCHES]
DRAWN BY: ZRJ	APP ROVED BY:	SCALE: 1:1

PC FILE NAME:
 STK-DIN

COPYRIGHT 2008 BY CUI INC.

ITEM	DESCRIPTION	QUANTITY
1	VDRP-03	1
2	M4X5 SCREWS	2

REV.	DESCRIPTION	DATE
A	NEW DRAWING	7/22/2008
B	multiple part updated	7/30/2010
C	mechanical change to the bracket shape	1/23/2012
D	updated drawing	4/27/2018
E	updated screw qty	12/15/2022

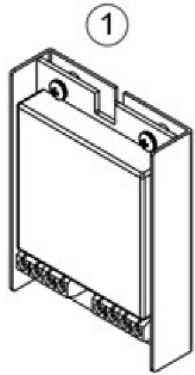

CUI CHASSIS MOUNT CONVERTER
QTY: 1
(sold separately)

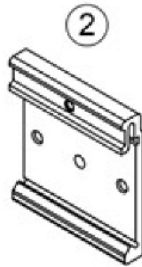

VDRP-03
QTY: 1



M4X5
QTY: 2

STEP 1 REMOVE PCB ASSEMBLY FROM CUI CHASSIS MOUNT CONVERTER U-FRAME BY LOOSENING THREE M3X5 SCREWS

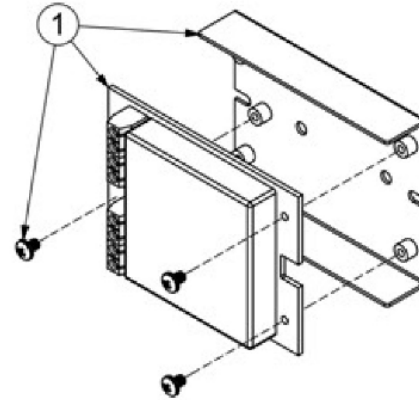

STEP 2 ATTACH VDRP-03 TO CUI CHASSIS MOUNT CONVERTER U-FRAME USING TWO M4X5 SCREWS

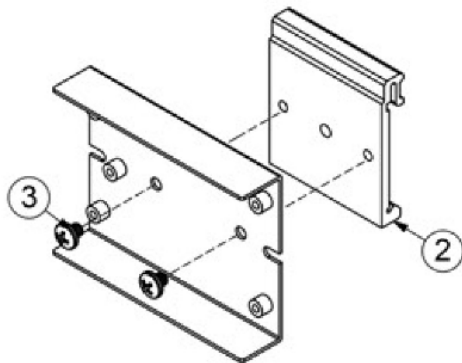

STEP 3 REATTACH PCB ASSEMBLY TO U-FRAME OF CUI CHASSIS MOUNT CONVERTER USING THREE M3X5 SCREWS

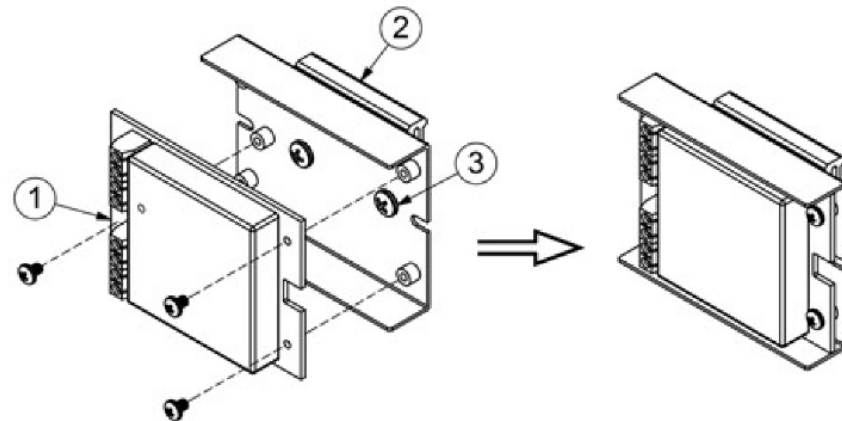

PC FILE NAME:
STK-DIN

COPYRIGHT 2008 BY CUI INC.

TITLE: DIN RAIL MOUNTING BRACKET ASSEMBLY INSTRUCTIONS		REV: D
PART NO. STK-DIN	UNITS: MM [INCHES]	
DRAWN BY: ZRJ	APP ROVED BY:	SCALE: 1:2