

TPS65560EVM-165

This user's guide describes the characteristics, operation, and use of the TPS65560EVM-165 Evaluation Module (EVM). This EVM demonstrates the Texas Instruments TPS65560 Integrated Photo Flash Chargers with IGBT Drivers. This user's guide includes setup instructions, a schematic diagram, a bill of materials, and printed-circuit board layout drawings for the evaluation module.

Contents

1	Introduction	1
2	Setup	2
3	Board Layout	5
4	Schematic and Bill of Materials	7
5	Related Documentation From Texas Instruments	8

List of Figures

1	Top Assembly Layer.....	5
2	Bottom Assembly Layer.....	5
3	Top Layer Routing	6
4	Bottom Layer Routing	6

List of Tables

1	J5 Pinout	2
2	TPS65560EVM-165 Bill of Materials	8

1 Introduction

The TPS65560 is a highly integrated flyback converter used to charge photo flash capacitors. The Texas Instruments TPS65560EVM-165 evaluation module (EVM) helps designers evaluate the operation and performance of this device.

The EVM contains one fully functional photo flash charger capable of charging a photo flash capacitor to 320 volts from a battery with voltage between 1.6 and 12 volts. The EVM also provides a flash lamp and trigger circuit to help the designer evaluate the charging characteristics. The onboard lamp circuit can be disabled so that the EVM can be connected to a user-supplied lamp and trigger circuit.

2 Setup

This section describes the jumpers and connectors on the EVM as well as how to properly connect, set up, and use the TPS65560EVM-165.

WARNING

The TPS65560EVM-165 produces high voltage and is designed to charge the bulk flash capacitor to more than 320 volts. This capacitor can maintain this voltage for a long time, even after the input power has been removed from the board. Do not touch any exposed metal on the TPS65560EVM-165 without first discharging the bulk flash capacitor.

2.1 Input / Output Connector Descriptions

2.1.1 J1 – Vbatt

This is the positive battery voltage input connection to the converter. This voltage should be between 1.6 and 12 volts dc.

2.1.2 J2 – GND

This is the return connection for the battery voltage to the converter.

2.1.3 J3 –V_{CC}

This is the positive digital voltage supply. This voltage should be between 2.7 and 4 volts dc.

2.1.4 J4 – GND

This is the return connection for the digital voltage supply.

2.1.5 J5 – REMOTE CONTROL

This connector is used to interface the EVM to a personal computer as an optional method of controlling the EVM. All necessary control inputs and outputs for the converter are present on this connector. The flash and charge signals are inverted before connecting to the TPS65560 on the EVM board. The pinout for the connector is shown [Table 1](#).

Table 1. J5 Pinout

Pin No.	Signal	Function
1, 3, 5, 7, 9	GND	Signal ground
2	Charge Complete	Output: An active low indicates the flash capacitor is charged
4	Charge	Input: A positive edge initiates the charging of the flash capacitor
6	Flash	Input: A logic-high signal initiates a lamp flash
8	I_PEAK	Input: Used to provide the peak current set point of the charger
10	V _{CC}	This pin is connected to the V _{CC} plane of the EVM board

2.1.6 J6 –User Lamp module HV connections

This connector is used to connect the EVM module to a user-supplied lamp and trigger circuit. Pin 1 of this connector is the trigger signal. Pin 2 of this connector is the high-voltage side of the photo flash capacitor. See the EVM schematic for more information

2.1.7 J7 –User Lamp module HV Return connections

This connector is used to connect the EVM module to a user-supplied lamp and trigger circuit. Both pins of this connector are connected to the negative side of the photo flash capacitor and provide the return path for the flash currents.

2.1.8 JP1 & JP2 – EVM Lamp disconnect

These jumpers are used to disconnect the lamp and trigger circuit of the EVM so that a user-supplied lamp and trigger can be evaluated. The lamp and trigger are disconnected when both jumpers JP1 and JP2 are removed.

2.1.9 JP3 –I_PEAK

This connector is used to externally set the charge current. Pin 2 of this connector is tied directly to the I_PEAK pin of the TPS65560. Connecting a jumper from pin 2 (I_PEAK) to pin 1 (V_{CC}) configures the TPS65560 to charge the flash capacitor using the maximum peak current. Connecting a jumper from pin 2 (I_PEAK) to pin 3 (GND) configures the TPS65560 to charge the flash capacitor using the minimum peak current. Other peak current levels can be programmed by installing resistors in positions R6 and R7 on the EVM board. R6 and R7 can be used to form a voltage divider between V_{CC} and GND to set the voltage on the I-Peak pin of the TPS65560.

2.2 Setup and Operation With Onboard Lamp and Trigger Circuit

1. Discharge the photo flash capacitor by shorting C5 with a 15-k Ω resistor for over 20 seconds. Use a multimeter to measure the voltage on C5 and verify that the voltage is close to zero before continuing or touching any connectors or components.
2. If needed, install jumpers across JP1 and JP2 to connect the onboard lamp and trigger circuit to the control circuitry.
3. Connect the positive lead of an input power supply J3. This voltage should be between 2.7 and 4 volts dc to supply V_{CC} to the TPS65560.
4. Connect the negative lead of an input power supply to J4.
5. Connect the positive lead of a battery or power supply to J1. This voltage can be between 1.6 and 12 volts.
6. Connect the negative of the battery or power supply to J2.
7. Turn on the V_{CC} input supply.
8. Turn on the battery voltage supply.
9. Push and hold the *Charge* button to start charging the flash capacitor.
10. Release the *Charge* button when the green *Charge Complete* LED (D2) illuminates.
11. Push the *Flash* switch to flash lamp.
12. Repeat steps 9 through 11 as needed.

2.3 Setup and Operation With User-Supplied Lamp and Trigger Circuit Operation

1. Discharge the photo flash capacitor by shorting C5 with a 15-k Ω resistor for over 20 seconds. Use a multimeter to measure the voltage on C5 and verify the voltage is close to zero before continuing or touching any connectors or components.
 2. Remove jumpers across JP1 and JP2 to disconnect the onboard lamp and trigger circuit from the control circuitry. The TPS65560 EVM should only be used to flash a single flash tube.
 3. Connect the high-voltage portion of the user supplied lamp circuit to pin 2 of J6.
 4. Connect the trigger portion of the user-supplied lamp to pin 1 of J6. See the EVM schematic to verify the circuit hook up.
 5. Connect the ground portion of the user lamp circuit to pin 1 of J7
 6. Connect the positive lead of an input power supply J3. This voltage should be between 2.7 and 4 volts dc to supply V_{CC} to the TPS65560.
 7. Connect the negative lead of an input power supply to J4.
 8. Connect the positive lead of a battery or power supply to J1. This voltage can be between 1.6 and 12 volts.
 9. Connect the negative of the battery or power supply to J2.
 10. Turn on the V_{CC} input supply.
 11. Turn on the battery voltage supply.
 12. Push and hold the *Charge* switch to start charging the flash capacitor.
 13. Release *Charge* switch when the green *Charge Complete* LED (D2) illuminates.
 14. Push the *Flash* switch to flash lamp.
- Repeat steps 12 through 14 as necessary.

3 Board Layout

This section provides the TPS65560EVM-165 board layout and illustrations.

3.1 Layout

Board layout is critical for all high-frequency switch mode power supplies. [Figure 1](#) through [Figure 4](#) show the board layout for the TPS65560EVM-165 PCB. The nodes with high-switching frequencies and currents are kept as short as possible to minimize trace inductance. Careful attention has been given to the routing of high-frequency current loops and a single-point grounding scheme is used for all high-current and high-voltage traces. See the data sheet for specific layout guidelines.

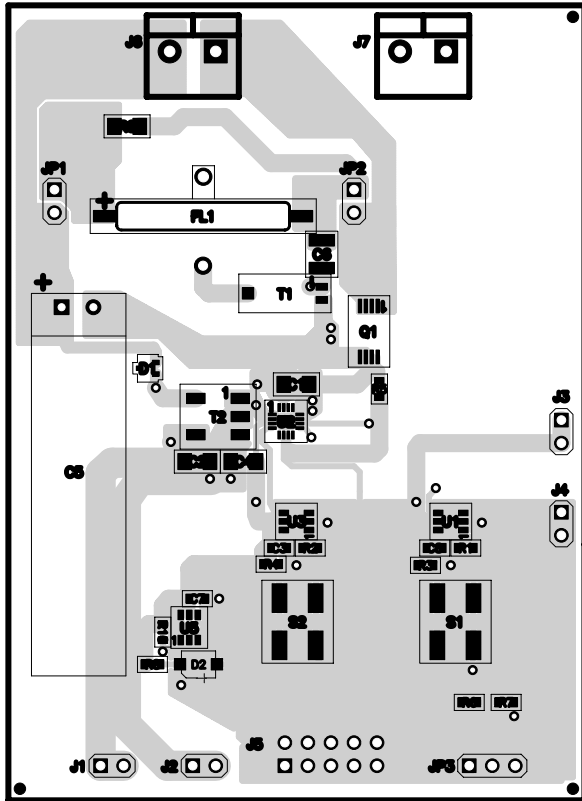

Figure 1. Top Assembly Layer

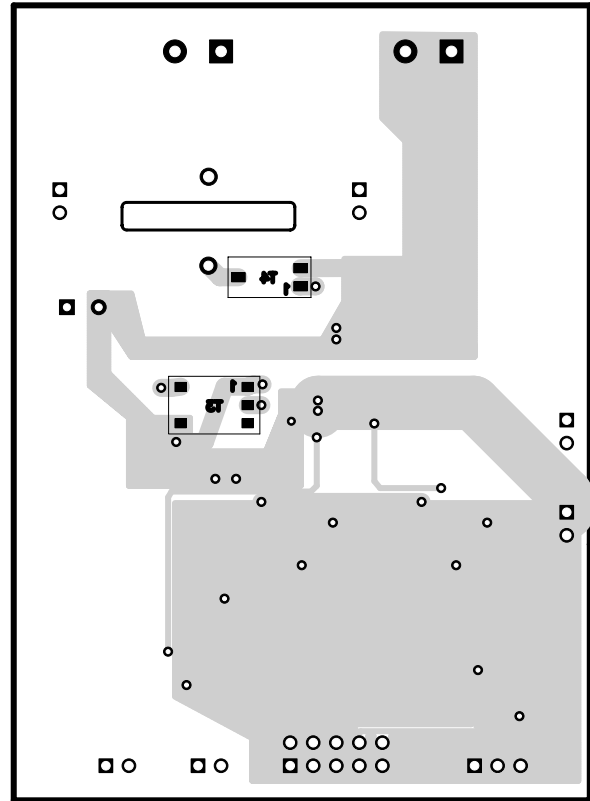

Figure 2. Bottom Assembly Layer

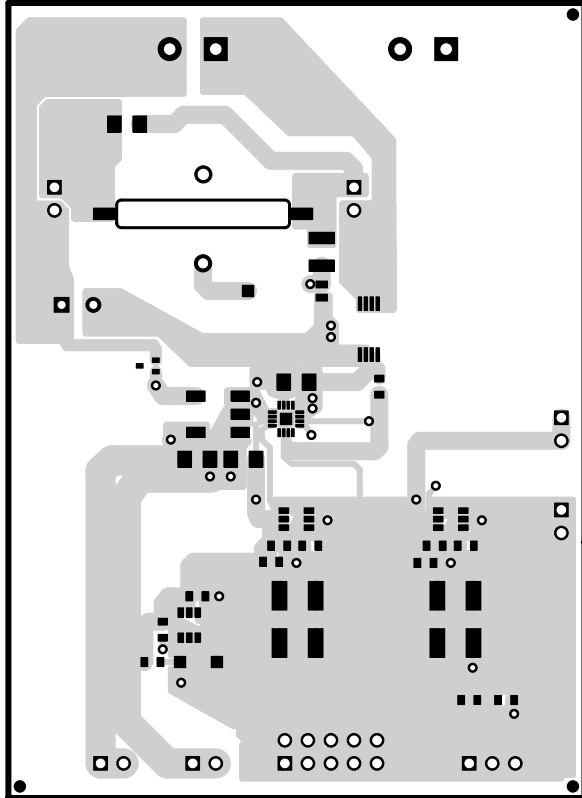

Figure 3. Top Layer Routing

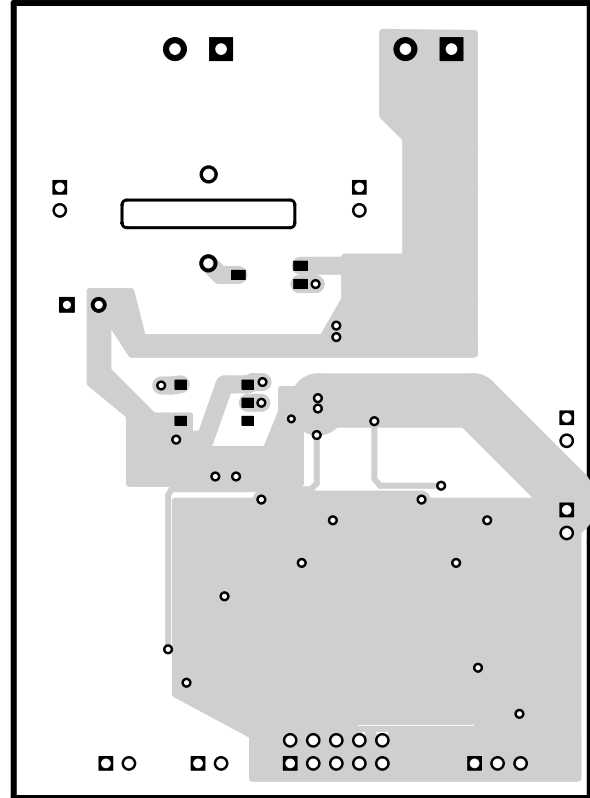
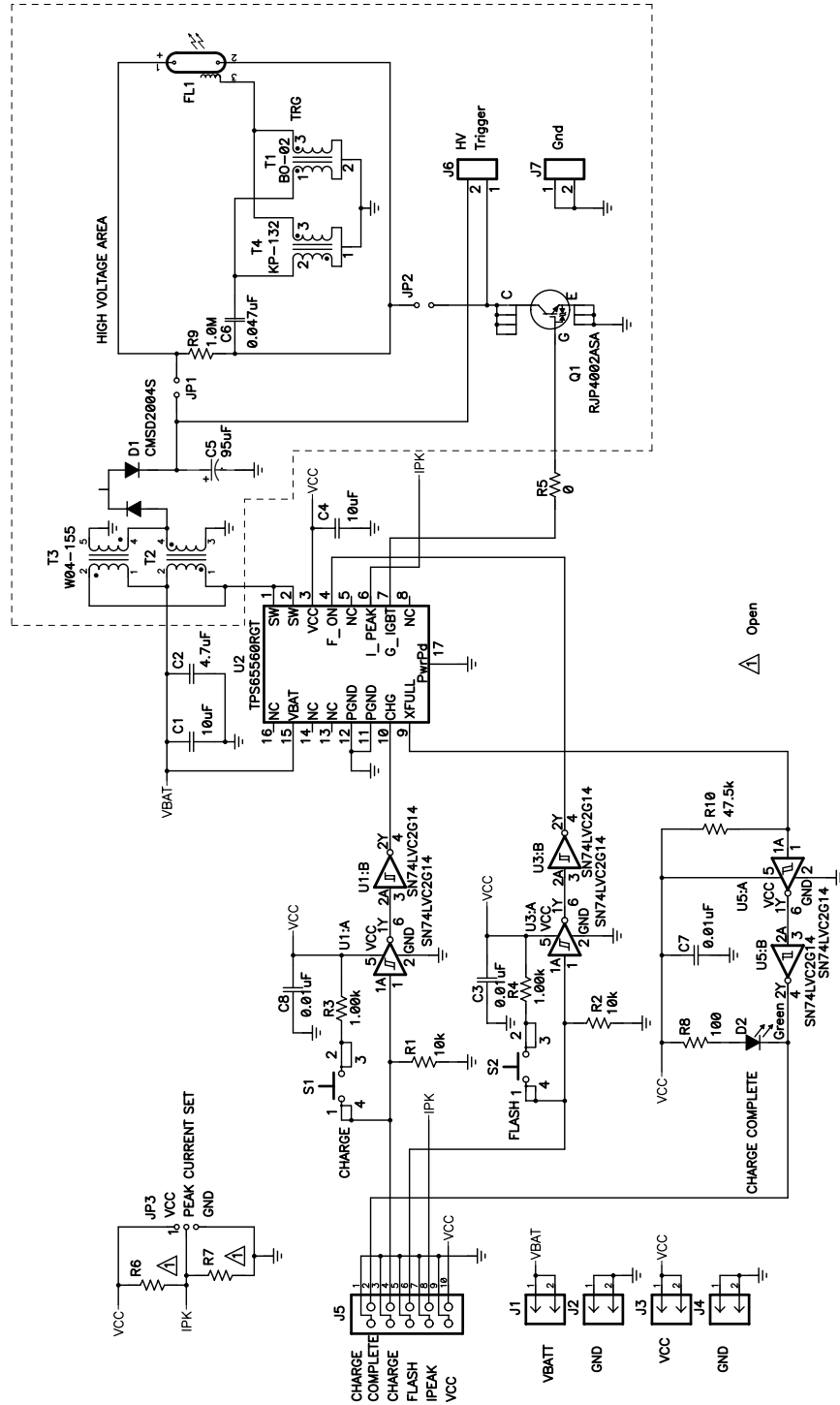

Figure 4. Bottom Layer Routing

4 Schematic and Bill of Materials

This section provides the TPS65560EVM-165 schematic and bill of materials.

4.1 Schematic



4.2 Bill of Materials

Table 2. TPS65560EVM-165 Bill of Materials

Count	RefDes	Value	Description	Size	Part Number	MFR
2	C1, C4	10 μ F	Capacitor, Ceramic, 16V, X7R, 10%	1206	C3216X7R1C106KT	TDK
1	C2	4.7 μ F	Capacitor, Ceramic, 25V, X7R, 10%	1206	C3216X7R1E475K	TDK
3	C3, C7, C8	0.01 μ F	Capacitor, Ceramic, 50V, X7R, 10%	0603	C1608X7R1H103KT	TDK
1	C5	95 μ F	Capacitor, Aluminum, 330VDC, 20%	9.5 x 37 mm	330FW95V9537	Rubycon
1	C6	0.047 μ F	Capacitor, Ceramic, 630V, X7R, 10%	1210	C3225X7R2J473K	TDK
1	D1		Diode, Dual Switching, 300V, 275mA, 225mA	SOT-323	CMSD2004S	Central Semiconductor
1	D2		Diode, LED, Green, Gullwing, GW Type, 20mA, 7.5 mcd typ.	0.120 x 0.087	LN1361CTR	Panasonic
1	FL1		Flash Tube, 320v Max	0.071 x 0.807 inch	FFT-N-I018001850-1	Nam Kwong Electric www.namkwong.com.hk
4	J1 - J4		Header, 2-pin, 100mil spacing, (36-pin strip)	0.100 x 2	PTC36SAAN	Sullins
1	J5		Header, 2x5-pin, 100mil spacing (36-pin strip)	0.100 x 5 X 2	PTC36DAAN	Sullins
2	J6, J7		Terminal Block, 2 pin, 15A, 5.1mm	0.40 x 0.35	ED1609	OST
2	JP1, JP2		Header, 2 pin, 100mil spacing, (36-pin strip)	0.100 x 2	PTC36SAAN	Sullins
1	JP3		Header, 3 pin, 100mil spacing, (36-pin strip)	0.100 x 3	PTC36SAAN	Sullins
1	Q1		Trans, N-Ch IGBT, Vgem 6, Vces 400, lcm 150	TSSOP-8	RJP4002ASA	Renesas
2	R1, R2	10k	Resistor, Chip, 1/16W, 1%	0603	Std	Std
1	R10	47.5k	Resistor, Chip, 1/16W, 1%	0603	Std	Std
2	R3, R4	1.00k	Resistor, Chip, 1/16W, 1%	0603	Std	Std
1	R5	0	Resistor, Chip, 1/16W, 5%	0603	Std	Std
2	R6, R7	Open	Resistor, Chip, 1/16W, 1%	0603		
1	R8	100	Resistor, Chip, 1/16W, 1%	0603	Std	Std
1	R9	1.0M	Resistor, Chip, 1/4W, 5%, 400V	1206	ERJ8GEYJ105V	Panasonic
2	S1, S2		Switch, SPST, PB Momentary, Sealed Washable	0.245 X 0.251	KT11P2JM	C & K
0	T1		Transformer, Trigger	0.330 X 0.137 inch	BO-02	Tokyo Coil
0	T2		Transformer,	0.303 x 0.252 inch	TTRN-038S_Type	Tokyo Coil
1	T3		XFMR, Flyback	0.220 X 0.335 inch	W04-155	Kijima-Musen t_ishino@kijima-m.co.jp
1	T4		XFMR, Trigger	0.146 X 0.303 inch	KP-132	Kijima-Musen
3	U1, U3, U5		IC, Dual Schmitt-Trigger Inverter	SOT23-6	SN74LVC2G14DBV	TI
1	U2		IC, Integrated Photo Flash charger and IGBT Driver	QFN16	TPS65560RGT	TI
1	-		PCB, 3.45 In x 2.5 In x 0.062 In		HPA165	Any
3	-		Shunt, 100-mil, Black	0.100	929950-00	3M
4	-		Bumpon, Transparent	0.44 x 0.2	SJ5303	3M
1			26 AWG Buss Wire (approximately 1.5 inches)			

- Notes: 1. These assemblies are ESD sensitive, ESD precautions shall be observed.
 2. These assemblies must be clean and free from flux and all contaminants. Use of unclean flux is not acceptable.
 3. These assemblies must comply with workmanship standards IPC-A-610 Class 2.
 4. Reference designators marked with an asterisk (***) cannot be substituted.
 All other components can be substituted with equivalent MFG's components.

5 Related Documentation From Texas Instruments

TPS65560 data.sheet ([SLVS608](#))

5.1 If You Need Assistance

Contact your local TI sales representative.

EVALUATION BOARD/KIT IMPORTANT NOTICE

Texas Instruments (TI) provides the enclosed product(s) under the following conditions:

This evaluation board/kit is intended for use for **ENGINEERING DEVELOPMENT, DEMONSTRATION, OR EVALUATION PURPOSES ONLY** and is not considered by TI to be a finished end-product fit for general consumer use. Persons handling the product(s) must have electronics training and observe good engineering practice standards. As such, the goods being provided are not intended to be complete in terms of required design-, marketing-, and/or manufacturing-related protective considerations, including product safety and environmental measures typically found in end products that incorporate such semiconductor components or circuit boards. This evaluation board/kit does not fall within the scope of the European Union directives regarding electromagnetic compatibility, restricted substances (RoHS), recycling (WEEE), FCC, CE or UL, and therefore may not meet the technical requirements of these directives or other related directives.

Should this evaluation board/kit not meet the specifications indicated in the User's Guide, the board/kit may be returned within 30 days from the date of delivery for a full refund. **THE FOREGOING WARRANTY IS THE EXCLUSIVE WARRANTY MADE BY SELLER TO BUYER AND IS IN LIEU OF ALL OTHER WARRANTIES, EXPRESSED, IMPLIED, OR STATUTORY, INCLUDING ANY WARRANTY OF MERCHANTABILITY OR FITNESS FOR ANY PARTICULAR PURPOSE.**

The user assumes all responsibility and liability for proper and safe handling of the goods. Further, the user indemnifies TI from all claims arising from the handling or use of the goods. Due to the open construction of the product, it is the user's responsibility to take any and all appropriate precautions with regard to electrostatic discharge.

EXCEPT TO THE EXTENT OF THE INDEMNITY SET FORTH ABOVE, NEITHER PARTY SHALL BE LIABLE TO THE OTHER FOR ANY INDIRECT, SPECIAL, INCIDENTAL, OR CONSEQUENTIAL DAMAGES.

TI currently deals with a variety of customers for products, and therefore our arrangement with the user **is not exclusive.**

TI assumes **no liability for applications assistance, customer product design, software performance, or infringement of patents or services described herein.**

Please read the User's Guide and, specifically, the Warnings and Restrictions notice in the User's Guide prior to handling the product. This notice contains important safety information about temperatures and voltages. For additional information on TI's environmental and/or safety programs, please contact the TI application engineer or visit www.ti.com/esh.

No license is granted under any patent right or other intellectual property right of TI covering or relating to any machine, process, or combination in which such TI products or services might be or are used.

FCC Warning

This evaluation board/kit is intended for use for **ENGINEERING DEVELOPMENT, DEMONSTRATION, OR EVALUATION PURPOSES ONLY** and is not considered by TI to be a finished end-product fit for general consumer use. It generates, uses, and can radiate radio frequency energy and has not been tested for compliance with the limits of computing devices pursuant to part 15 of FCC rules, which are designed to provide reasonable protection against radio frequency interference. Operation of this equipment in other environments may cause interference with radio communications, in which case the user at his own expense will be required to take whatever measures may be required to correct this interference.

EVM WARNINGS AND RESTRICTIONS

It is important to operate this EVM within the input voltage range of 1.6 V to 12 V (V_{batt}), 2.7 V to 4 V (V_{cc}) and the output voltage range of 0 V to 320 V.

Exceeding the specified input range may cause unexpected operation and/or irreversible damage to the EVM. If there are questions concerning the input range, please contact a TI field representative prior to connecting the input power.

Applying loads outside of the specified output range may result in unintended operation and/or possible permanent damage to the EVM. Please consult the EVM User's Guide prior to connecting any load to the EVM output. If there is uncertainty as to the load specification, please contact a TI field representative.

During normal operation, some circuit components may have case temperatures greater than 50°C. The EVM is designed to operate properly with certain components above 50°C as long as the input and output ranges are maintained. These components include but are not limited to linear regulators, switching transistors, pass transistors, and current sense resistors. These types of devices can be identified using the EVM schematic located in the EVM User's Guide. When placing measurement probes near these devices during operation, please be aware that these devices may be very warm to the touch.

Mailing Address: Texas Instruments, Post Office Box 655303, Dallas, Texas 75265
Copyright © 2008, Texas Instruments Incorporated

IMPORTANT NOTICE

Texas Instruments Incorporated and its subsidiaries (TI) reserve the right to make corrections, modifications, enhancements, improvements, and other changes to its products and services at any time and to discontinue any product or service without notice. Customers should obtain the latest relevant information before placing orders and should verify that such information is current and complete. All products are sold subject to TI's terms and conditions of sale supplied at the time of order acknowledgment.

TI warrants performance of its hardware products to the specifications applicable at the time of sale in accordance with TI's standard warranty. Testing and other quality control techniques are used to the extent TI deems necessary to support this warranty. Except where mandated by government requirements, testing of all parameters of each product is not necessarily performed.

TI assumes no liability for applications assistance or customer product design. Customers are responsible for their products and applications using TI components. To minimize the risks associated with customer products and applications, customers should provide adequate design and operating safeguards.

TI does not warrant or represent that any license, either express or implied, is granted under any TI patent right, copyright, mask work right, or other TI intellectual property right relating to any combination, machine, or process in which TI products or services are used. Information published by TI regarding third-party products or services does not constitute a license from TI to use such products or services or a warranty or endorsement thereof. Use of such information may require a license from a third party under the patents or other intellectual property of the third party, or a license from TI under the patents or other intellectual property of TI.

Reproduction of TI information in TI data books or data sheets is permissible only if reproduction is without alteration and is accompanied by all associated warranties, conditions, limitations, and notices. Reproduction of this information with alteration is an unfair and deceptive business practice. TI is not responsible or liable for such altered documentation. Information of third parties may be subject to additional restrictions.

Resale of TI products or services with statements different from or beyond the parameters stated by TI for that product or service voids all express and any implied warranties for the associated TI product or service and is an unfair and deceptive business practice. TI is not responsible or liable for any such statements.

TI products are not authorized for use in safety-critical applications (such as life support) where a failure of the TI product would reasonably be expected to cause severe personal injury or death, unless officers of the parties have executed an agreement specifically governing such use. Buyers represent that they have all necessary expertise in the safety and regulatory ramifications of their applications, and acknowledge and agree that they are solely responsible for all legal, regulatory and safety-related requirements concerning their products and any use of TI products in such safety-critical applications, notwithstanding any applications-related information or support that may be provided by TI. Further, Buyers must fully indemnify TI and its representatives against any damages arising out of the use of TI products in such safety-critical applications.

TI products are neither designed nor intended for use in military/aerospace applications or environments unless the TI products are specifically designated by TI as military-grade or "enhanced plastic." Only products designated by TI as military-grade meet military specifications. Buyers acknowledge and agree that any such use of TI products which TI has not designated as military-grade is solely at the Buyer's risk, and that they are solely responsible for compliance with all legal and regulatory requirements in connection with such use.

TI products are neither designed nor intended for use in automotive applications or environments unless the specific TI products are designated by TI as compliant with ISO/TS 16949 requirements. Buyers acknowledge and agree that, if they use any non-designated products in automotive applications, TI will not be responsible for any failure to meet such requirements.

Following are URLs where you can obtain information on other Texas Instruments products and application solutions:

Products

Amplifiers	amplifier.ti.com
Data Converters	dataconverter.ti.com
DSP	dsp.ti.com
Clocks and Timers	www.ti.com/clocks
Interface	interface.ti.com
Logic	logic.ti.com
Power Mgmt	power.ti.com
Microcontrollers	microcontroller.ti.com
RFID	www.ti-rfid.com
RF/IF and ZigBee® Solutions	www.ti.com/lprf

Applications

Audio	www.ti.com/audio
Automotive	www.ti.com/automotive
Broadband	www.ti.com/broadband
Digital Control	www.ti.com/digitalcontrol
Medical	www.ti.com/medical
Military	www.ti.com/military
Optical Networking	www.ti.com/opticalnetwork
Security	www.ti.com/security
Telephony	www.ti.com/telephony
Video & Imaging	www.ti.com/video
Wireless	www.ti.com/wireless

Mailing Address: Texas Instruments, Post Office Box 655303, Dallas, Texas 75265
Copyright © 2008, Texas Instruments Incorporated