

DATA SHEET

# SKY12355-337LF: 0.35 to 4.0 GHz Two-Bit Digital Attenuator

## Applications

- Cellular infrastructure
- Wireless receivers

## Features

- Positive voltage operation with integrated decoder
- Broadband operation: 0.35 to 4.0 GHz
- Attenuation: 18 dB with 6 dB LSB
- Low insertion loss: 0.6 dB @ 2 GHz
- Absorptive in 50 Ω systems
- Small QFN (12-pin, 3 x 3 mm) package (MSL1, 260 °C per JEDEC J-STD-020)



Skyworks Green™ products are compliant with all applicable legislation and are halogen-free. For additional information, refer to *Skyworks Definition of Green™*, document number SQ04-0074.

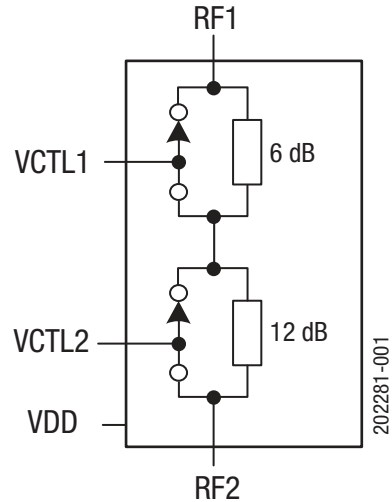

Figure 1. SKY12355-337LF Block Diagram

## Description

The SKY12355-337LF is a GaAs pHEMT two-bit digital attenuator I/C. The device is provided in a 3 x 3 mm, 12-pin Quad Flat No-Lead (QFN) package.

The SKY12355-337LF is particularly suited for low-cost commercial applications for which high attenuation accuracy, low insertion loss, and low intermodulation products are required.

A functional block diagram is shown in Figure 1. The pin configuration and package are shown in Figure 2. Signal pin assignments and functional pin descriptions are provided in Table 1.

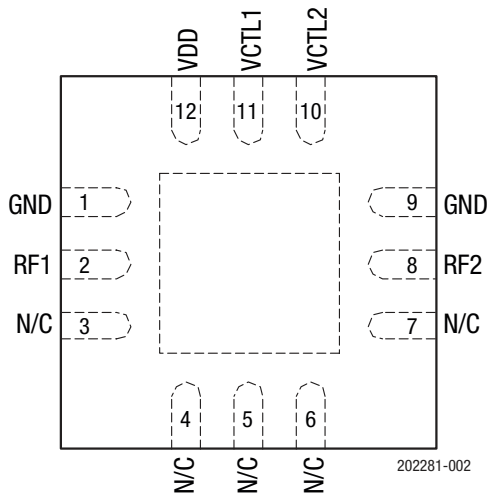

Figure 2. SKY12355-337LF Pinout (Top View)

**Table 1. SKY12355-337LF Signal Descriptions<sup>1</sup>**

Pin	Name	Description	Pin	Name	Description
1	GND	Ground	7	N/C	No connection required. May be connected to ground with no change in performance.
2	RF1	RF port. Must be DC blocked.	8	RF2	RF port. Must be DC blocked.
3	N/C	No connection required. May be connected to ground with no change in performance.	9	GND	Ground
4	N/C	No connection required. May be connected to ground with no change in performance.	10	VCTL2	DC control voltage. Controls 12 dB attenuation state. Refer to Table 4.
5	N/C	No connection required. May be connected to ground with no change in performance.	11	VCTL1	DC control voltage. Controls 6 dB attenuation state. Refer to Table 4.
6	N/C	No connection required. May be connected to ground with no change in performance.	12	VDD	DC power supply.

<sup>1</sup> Exposed pad must be grounded.

### Functional Description

This attenuator has a least significant bit (LSB) of 6 dB and a most significant bit (MSB) of 12 dB for a total of 18 dB available attenuation. Pins 10 and 11 (VCTL2 and VCTL1) control the state of the 6 dB and 12 dB attenuation bits, respectively. For each bit, a logic high enables the attenuation state while a logic low enables a low insertion loss state.

### Electrical and Mechanical Specifications

The absolute maximum ratings of the SKY12355-337LF are provided in Table 2. Electrical specifications are provided in Table 3.

The state of the SKY12355-337LF is determined by the logic provided in Table 4. The VCTL1 and VCTL2 signals control the 6 dB and 12 dB attenuation bits, respectively. For each bit, a logic high enables the attenuation state, while a logic low enables the insertion loss state.

Typical performance characteristics are illustrated in Figures 3 to 6.

**Table 2. SKY12355-337LF Absolute Maximum Ratings<sup>1</sup>**

Parameter	Symbol	Minimum	Typical	Maximum	Units
Supply voltage	V <sub>DD</sub>			5.5	V
Control voltage	V <sub>CTL1</sub> , V <sub>CTL2</sub>			V <sub>DD</sub> + 0.1	V
RF input power @ 3 V	P <sub>IN</sub>			+28	dBm
RF input power:					
T <sub>CASE</sub> ≤ +85 °C	P <sub>IN</sub>			+28	dBm
T <sub>CASE</sub> = +105 °C	P <sub>IN_105C</sub>			+21	dBm
Operating temperature	T <sub>OP</sub>	-40		+105	°C
Storage temperature	T <sub>STG</sub>	-65		+150	°C
Junction temperature	T <sub>JC</sub>	-65		+150	°C
Electrostatic discharge:	ESD				
Charged-Device Model (Class 4)				1000	V
Human Body Model (Class 1A)				250	V
Machine Model (Class A)				100	V

<sup>1</sup> Exposure to maximum rating conditions for extended periods may reduce device reliability. There is no damage to device with only one parameter set at the limit and all other parameters set at or below their nominal value. Exceeding any of the limits listed here may result in permanent damage to the device.

**ESD HANDLING:** Although this device is designed to be as robust as possible, electrostatic discharge (ESD) can damage this device. This device must be protected at all times from ESD when handling or transporting. Static charges may easily produce potentials of several kilovolts on the human body or equipment, which can discharge without detection. Industry-standard ESD handling precautions should be used at all times.

**Table 3. SKY12355-337LF Electrical Specifications<sup>1</sup> (1 of 2)**

(V<sub>DD</sub> = 3 V, V<sub>CTL</sub> = 0 to 3 V, T<sub>OP</sub> = +25 °C, P<sub>IN</sub> = 0 dBm, Characteristic Impedance [Z<sub>0</sub>] = 50 Ω, C1 and C2 = 1000 pF, Unless Otherwise Noted)

Parameter	Symbol	Test Condition	Min	Typical	Max	Units	
Insertion loss	IL	350 MHz to 500 MHz		0.45	0.80	dB	
		500 MHz to 2 GHz		0.65	0.80	dB	
		2 GHz to 3 GHz		0.65	0.90	dB	
		3 GHz to 4 GHz		0.75	1.00	dB	
Attenuation accuracy (normalized to insertion loss)	Att	@ 6 dB:					
		350 MHz to 500 MHz	5.7	6.0	6.3	dB	
		500 MHz to 2 GHz	5.9	6.2	6.5	dB	
		2 GHz to 3 GHz	6.1	6.4	6.7	dB	
		3 GHz to 4 GHz	6.1	6.4	6.7	dB	
		@ 12 dB:					
		350 MHz to 500 MHz	11.9	12.2	12.5	dB	
		500 MHz to 2 GHz	12.0	12.3	12.6	dB	
		2 GHz to 3 GHz	11.9	12.2	12.5	dB	
		3 GHz to 4 GHz	11.8	12.1	12.4	dB	
		@ 18 dB:					
		350 MHz to 500 MHz	17.9	18.3	18.7	dB	
500 MHz to 2 GHz	18.3	18.6	18.9	dB			
2 GHz to 3 GHz	18.3	18.6	18.9	dB			
3 GHz to 4 GHz	18.3	18.6	18.9	dB			

**Table 3. SKY12355-337LF Electrical Specifications<sup>1</sup> (2 of 2)**

(V<sub>DD</sub> = 3 V, V<sub>CTL</sub> = 0 to 3 V, T<sub>OP</sub> = +25 °C, P<sub>IN</sub> = 0 dBm, Characteristic Impedance [Z<sub>0</sub>] = 50 Ω, C1 and C2 = 1000 pF, Unless Otherwise Noted)

Parameter	Symbol	Test Condition	Min	Typical	Max	Units
Return loss	IS11l	350 to 500 MHz	10	20		dB
		500 MHz to 2 GHz	14	22		dB
		2 GHz to 3 GHz	12	19		dB
		3 GHz to 4 GHz	12	19		dB
Switching characteristics: Rise/fall time		10% RF to 90% RF or 90% RF to 10% RF		8		ns
On/off time		50% V <sub>CTL</sub> to 90% RF or 50% V <sub>CTL</sub> to 10% RF		37		ns
Attenuation amplitude settling		500 ns to 5 ms			0.25	dB
Phase settling (by design)		500 ns to 5 ms	-2		+2	deg
1 dB input compression point	IP1dB	V <sub>CTL</sub> = 3 V, 500 MHz to 4 GHz, insertion state		+28		dBm
0.1 dB input compression point	IP0.1dB	V <sub>CTL</sub> = 3 V, 500 MHz to 4 GHz, all states		+19		dBm
Third order input intercept point	IIP3	Tone spacing = 20 MHz, power/tone = +18 dBm, V <sub>DD</sub> = V <sub>CTL1</sub> = V <sub>CTL2</sub> = 3.3 V, 500 MHz to 4 GHz:  Insertion loss state	+48	+50		dBm
			All attenuation states	+44	+47	
Supply voltage	V <sub>DD</sub>		3		5	V
Control voltage		V <sub>DD</sub>	3		5	V
		V <sub>CTL</sub> = low	0		0.3 × V <sub>DD</sub>	V
		V <sub>CTL</sub> = high	0.7 × V <sub>DD</sub>		V <sub>DD</sub>	V
Control current		V <sub>CTL</sub> = low and V <sub>CTL</sub> = high		10		μA
Supply current	I <sub>DD</sub>			20	50	μA

<sup>1</sup> Performance is guaranteed only under the conditions listed in this table.

**Table 4. SKY12355-337LF Truth Table**

State	V <sub>DD</sub>	V <sub>CTL1</sub>	V <sub>CTL2</sub>
Insertion loss	High	Low	Low
6 dB	High	High	Low
12 dB	High	Low	High
18 dB	High	High	High

<sup>1</sup> High = 0.7 × V<sub>DD</sub> to V<sub>DD</sub>

Low = 0 to 0.3 × V<sub>DD</sub>

Any state other than described in this table places the attenuator into an undefined state.

### Typical Performance Characteristics

(VDD = 3 V, VCTL = 0 to 3 V, TOP = +25 °C, PIN = 0 dBm, Characteristic Impedance [Zo] = 50 Ω, C1 and C2 = 1000 pF, Unless Otherwise Noted)

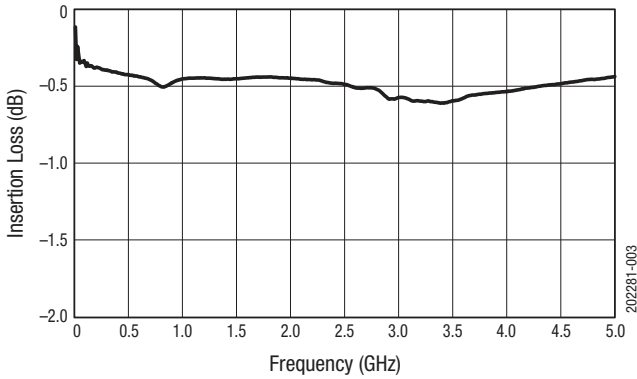

Figure 3. Insertion Loss vs Frequency

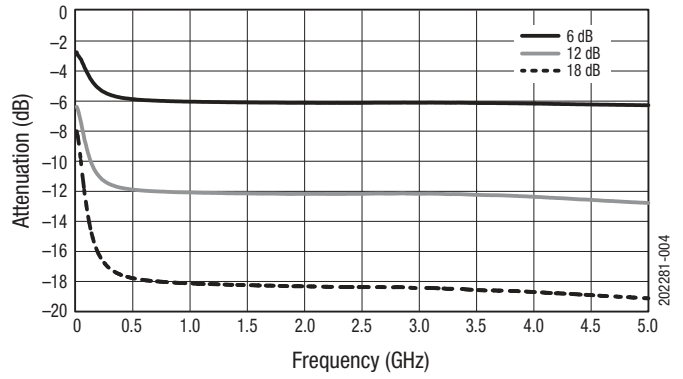

Figure 4. Attenuation vs Frequency (Normalized to Insertion Loss)

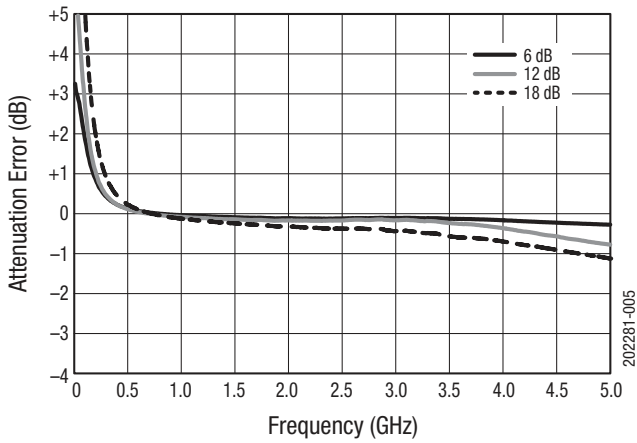

Figure 5. Attenuation Error vs Frequency (Normalized to Insertion Loss)

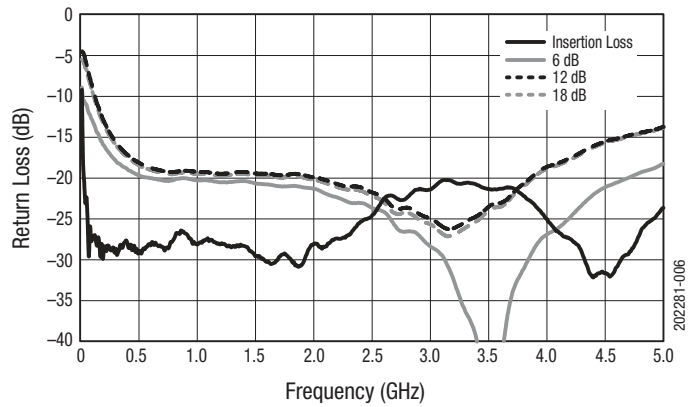

Figure 6. Return Loss vs Frequency

### Evaluation Board Description

The SKY12355-337LF Evaluation Board is used to test the performance of the SKY12355-337LF digital attenuator. An Evaluation Board schematic diagram is shown in Figure 7. Table 5 provides the Bill of Materials (BOM) list for Evaluation Board components. An assembly drawing for the Evaluation Board is shown in Figure 8.

### Package Dimensions

The PCB layout footprint for the SKY12355-337LF is shown in Figure 9. Typical part markings are noted in Figure 10. Package dimensions are shown in Figure 11, and tape and reel dimensions are provided in Figure 12.

### Package and Handling Information

Instructions on the shipping container label regarding exposure to moisture after the container seal is broken must be followed. Otherwise, problems related to moisture absorption may occur when the part is subjected to high temperature during solder assembly.

The SKY12355-337LF is rated to Moisture Sensitivity Level 1 (MSL1) at 260 °C. It can be used for lead or lead-free soldering. For additional information, refer to the Skyworks Application Note, *Solder Reflow Information*, document number 200164.

Care must be taken when attaching this product, whether it is done manually or in a production solder reflow environment. Production quantities of this product are shipped in a standard tape and reel format.

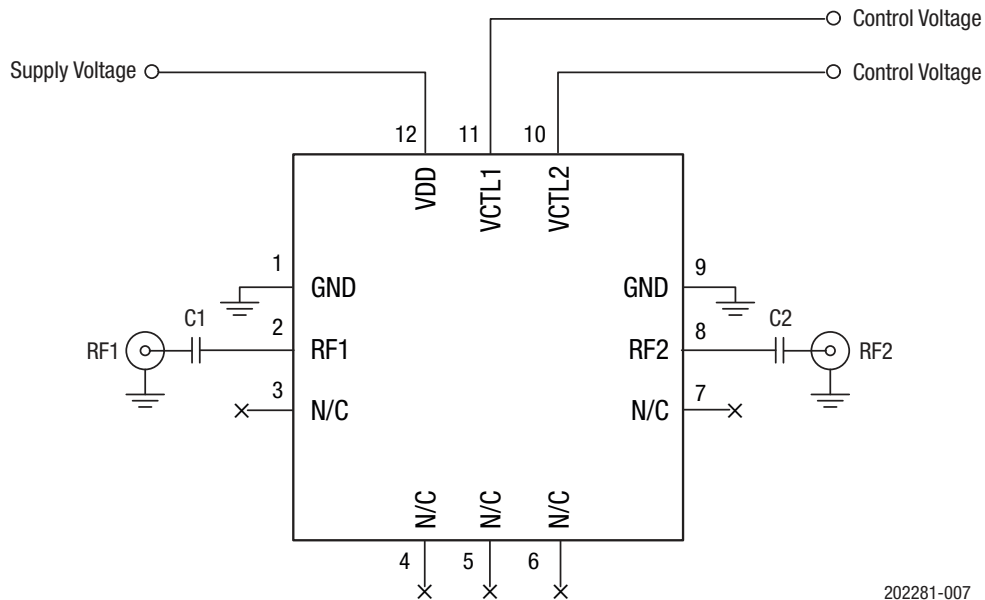

202281-007

Figure 7. SKY12355-337LF Evaluation Board Schematic Diagram

Table 5. SKY12355-337LF Evaluation Board Bill of Materials<sup>1</sup>

Component	Value	Size	Manufacturer/Part Series
C1, C2	1000 pF	0402	Murata GRM Series

<sup>1</sup> Blocking capacitors are required on both RF ports for proper functionality. Value of DC blocking capacitor determines lower frequency operation.

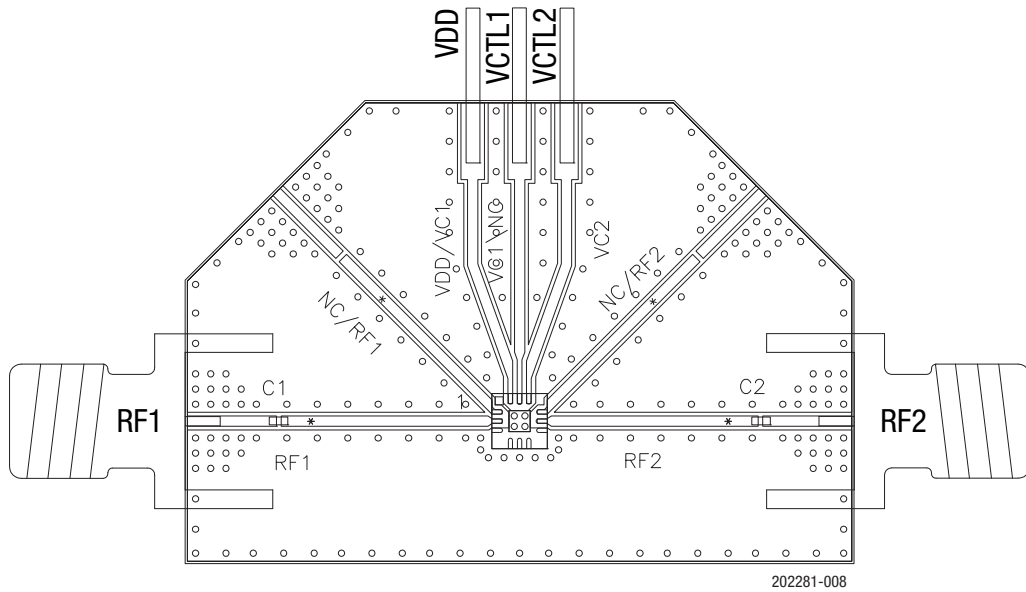

**Figure 8. SKY12355-337LF Evaluation Board Assembly Diagram**

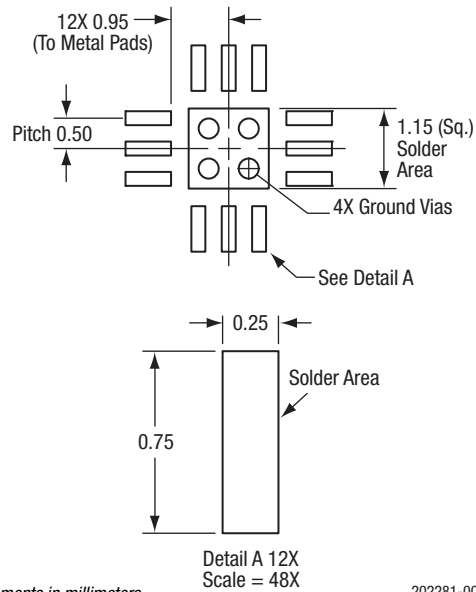

All measurements in millimeters

202281-009

**Figure 9. SKY12355-337LF PCB Layout Footprint**

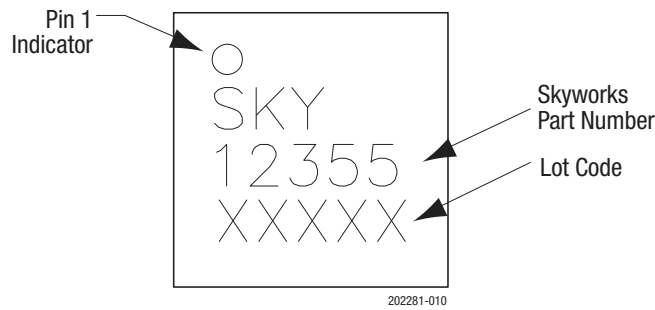
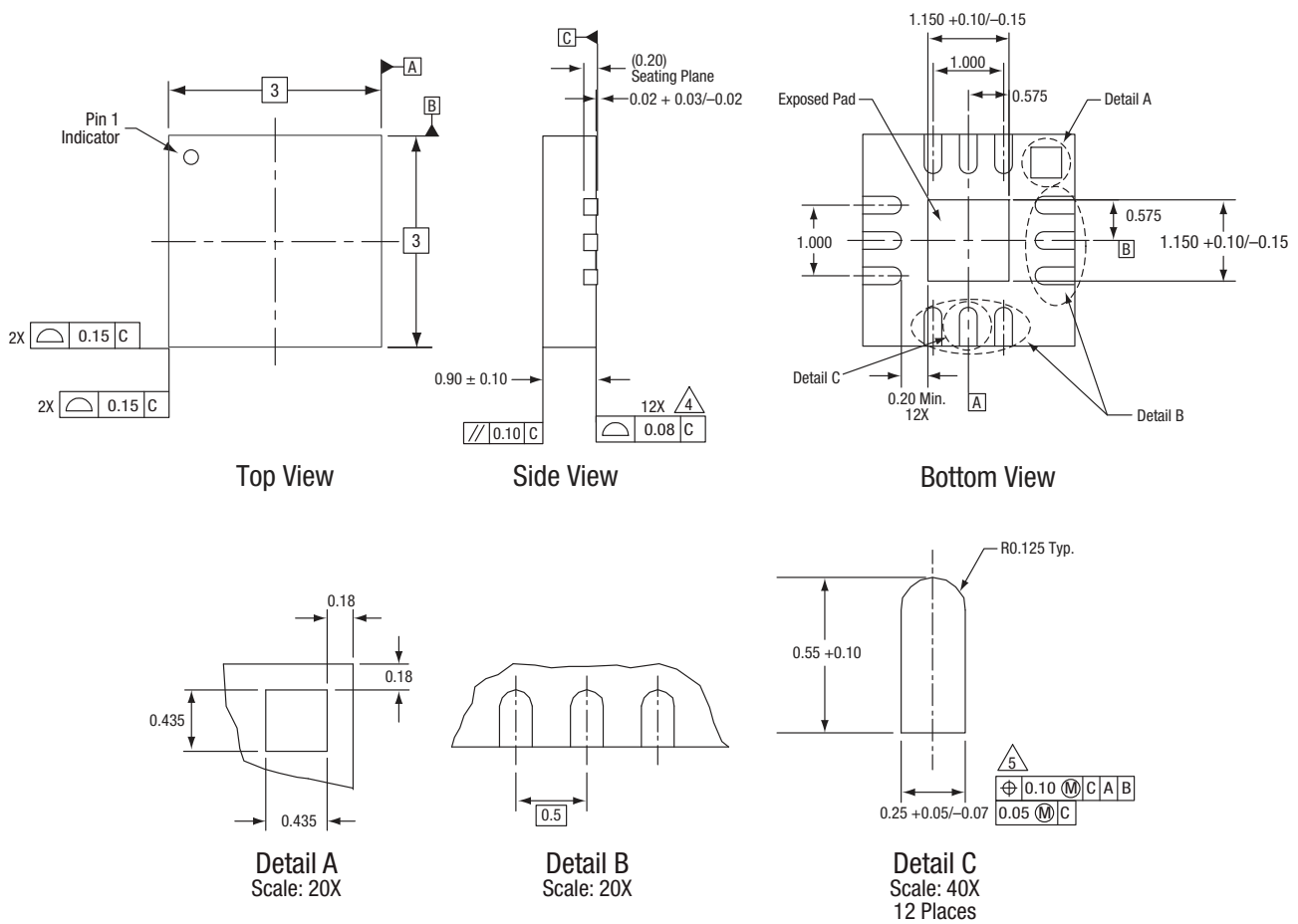

Figure 10. Typical Part Markings



Notes:

1. All measurements are in millimeters.
2. Dimensions and tolerances according to ASME Y14.5M-1994.
3. Unilateral coplanarity applies to the exposed heat sink pad as well as the terminals.
4. Plating requirement per source control drawing (SCD) 2504.
5. Dimension applies to metallized terminal and is measured between 0.15 and 0.30 mm from the terminal tip. Do not measure at radius area.

202281-011

Figure 11. SKY12355-337LF Package Dimensions



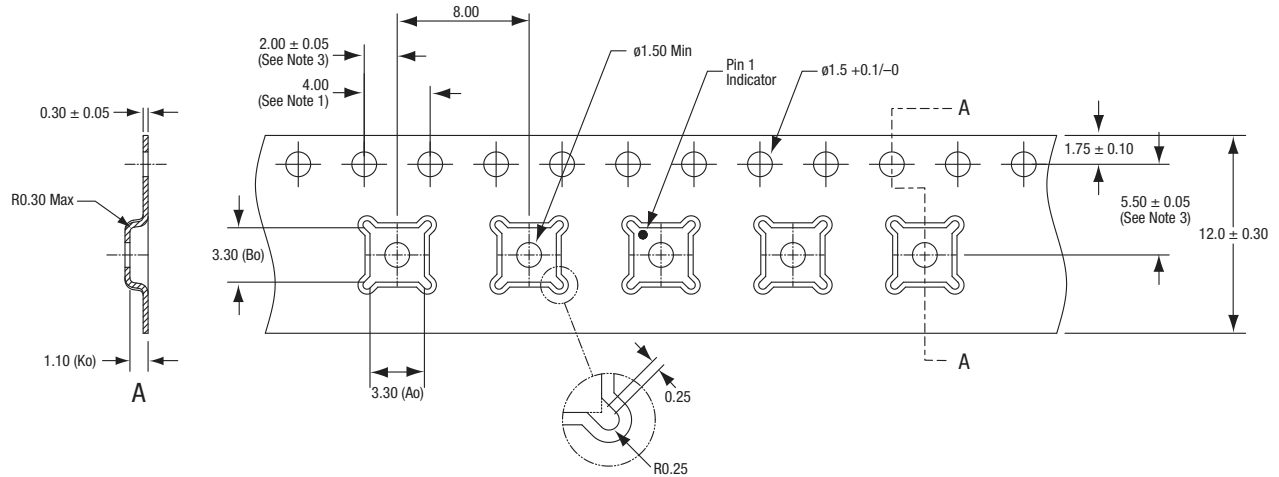

Notes:

1. Sprocket hole pitch cumulative tolerance:  $\pm 0.2$ .
2. Carrier tape: black conductive polystyrene.
3. Pocket position relative to sprocket hole, measure as true position of pocket, not pocket hole.
4. Cover tape material: transparent conductive PSA, 9.30 mm wide.
5. All dimensions are in millimeters.

202281-012

Figure 12. SKY12355-337LF Tape and Reel Dimensions

## Ordering Information

Model Name	Manufacturing Part Number	Evaluation Board Part Numbers
SKY12355-337LF: Digital Attenuator	SKY12355-337LF	SKY12355-337LF-EK1

Copyright © 2012-2013, 2016 Skyworks Solutions, Inc. All Rights Reserved.

Information in this document is provided in connection with Skyworks Solutions, Inc. ("Skyworks") products or services. These materials, including the information contained herein, are provided by Skyworks as a service to its customers and may be used for informational purposes only by the customer. Skyworks assumes no responsibility for errors or omissions in these materials or the information contained herein. Skyworks may change its documentation, products, services, specifications or product descriptions at any time, without notice. Skyworks makes no commitment to update the materials or information and shall have no responsibility whatsoever for conflicts, incompatibilities, or other difficulties arising from any future changes.

No license, whether express, implied, by estoppel or otherwise, is granted to any intellectual property rights by this document. Skyworks assumes no liability for any materials, products or information provided hereunder, including the sale, distribution, reproduction or use of Skyworks products, information or materials, except as may be provided in Skyworks Terms and Conditions of Sale.

THE MATERIALS, PRODUCTS AND INFORMATION ARE PROVIDED "AS IS" WITHOUT WARRANTY OF ANY KIND, WHETHER EXPRESS, IMPLIED, STATUTORY, OR OTHERWISE, INCLUDING FITNESS FOR A PARTICULAR PURPOSE OR USE, MERCHANTABILITY, PERFORMANCE, QUALITY OR NON-INFRINGEMENT OF ANY INTELLECTUAL PROPERTY RIGHT; ALL SUCH WARRANTIES ARE HEREBY EXPRESSLY DISCLAIMED. SKYWORKS DOES NOT WARRANT THE ACCURACY OR COMPLETENESS OF THE INFORMATION, TEXT, GRAPHICS OR OTHER ITEMS CONTAINED WITHIN THESE MATERIALS. SKYWORKS SHALL NOT BE LIABLE FOR ANY DAMAGES, INCLUDING BUT NOT LIMITED TO ANY SPECIAL, INDIRECT, INCIDENTAL, STATUTORY, OR CONSEQUENTIAL DAMAGES, INCLUDING WITHOUT LIMITATION, LOST REVENUES OR LOST PROFITS THAT MAY RESULT FROM THE USE OF THE MATERIALS OR INFORMATION, WHETHER OR NOT THE RECIPIENT OF MATERIALS HAS BEEN ADVISED OF THE POSSIBILITY OF SUCH DAMAGE.

Skyworks products are not intended for use in medical, lifesaving or life-sustaining applications, or other equipment in which the failure of the Skyworks products could lead to personal injury, death, physical or environmental damage. Skyworks customers using or selling Skyworks products for use in such applications do so at their own risk and agree to fully indemnify Skyworks for any damages resulting from such improper use or sale.

Customers are responsible for their products and applications using Skyworks products, which may deviate from published specifications as a result of design defects, errors, or operation of products outside of published parameters or design specifications. Customers should include design and operating safeguards to minimize these and other risks. Skyworks assumes no liability for applications assistance, customer product design, or damage to any equipment resulting from the use of Skyworks products outside of stated published specifications or parameters.

Skyworks and the Skyworks symbol are trademarks or registered trademarks of Skyworks Solutions, Inc., in the United States and other countries. Third-party brands and names are for identification purposes only, and are the property of their respective owners. Additional information, including relevant terms and conditions, posted at [www.skyworksinc.com](http://www.skyworksinc.com), are incorporated by reference.