

# CDC9841 PC MOTHERBOARD CLOCK SYNTHESIZER/DRIVER WITH 3-STATE OUTPUTS

SCAS458D – DECEMBER 1994 – REVISED APRIL 1996

- Four CPU Clock Outputs With Programmable Frequency (50 MHz, 60 MHz, and 66 MHz)
- Six Clock Outputs at Half-CPU Frequency for PCI
- One 24-MHz Clock Output
- One 12-MHz Clock Output
- Two 14.318-MHz Reference Outputs
- All Output Clock Frequencies Derived From a Single 14.31818-MHz Crystal Input
- LVTTTL-Compatible Inputs and Outputs
- Internal Loop Filters for Phase-Lock Loops Eliminate the Need for External Components
- Operates at 3.3 V<sub>CC</sub>
- Distributed V<sub>CC</sub> and Ground Pins Reduce Switching Noise
- Packaged in Plastic Small-Outline Package

DW PACKAGE  
(TOP VIEW)

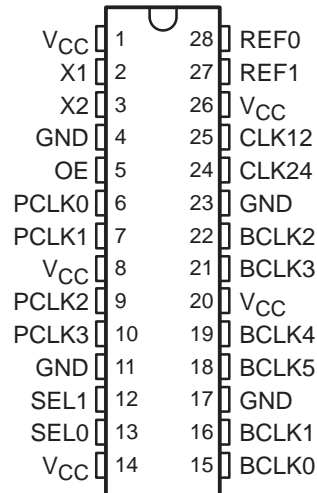

## description

The CDC9841 is a high-performance clock synthesizer/driver that generates all required clock signals necessary for a high-performance PC motherboard. The four central processing unit (CPU) clock outputs (PCLK<sub>n</sub>) are programmable to one of three frequencies (50 MHz, 60 MHz, or 66 MHz) via the SEL0 and SEL1 control inputs. The six peripheral-component-interconnect (PCI) clock outputs (BCLK<sub>n</sub>) are half the frequency of PCLK<sub>n</sub> and are delayed 1 ns to 4 ns from the rising edge of the CPU clock. In addition, the four fixed-frequency outputs provide a 24-MHz clock (CLK24), a 12-MHz clock (CLK12), and two buffered copies of the 14.318-MHz input reference (REF0, REF1).

The CDC9841 generates all output frequencies from a 14.31818-MHz crystal input. A reference clock can be provided at X1 instead of a crystal input.

Two phase-lock loops (PLLs) generate the CPU clock frequency and the 24-MHz clock frequency. On-chip loop filters and internal feedback eliminate the need for external components. The PCI and 12-MHz clock frequencies are derived from the base CPU and 24-MHz clock frequencies, respectively. The PLL circuit can be bypassed in the TEST mode (i.e., SEL0 = SEL1 = H) to distribute a test clock provided at the X1 input. Because the CDC9841 is based on PLL circuitry, it requires a stabilization time to achieve phase lock of the PLL. This stabilization time is required following power up and application of a fixed-frequency, fixed-phase signal at the X1 input, as well as following any changes to the SEL<sub>n</sub> inputs.

PCLK<sub>n</sub> and BCLK<sub>n</sub> provide low-skew/low-jitter clock signals for reliable clock operation. All outputs are 3 state and are enabled via OE.



Please be aware that an important notice concerning availability, standard warranty, and use in critical applications of Texas Instruments semiconductor products and disclaimers thereto appears at the end of this data sheet.

PRODUCTION DATA information is current as of publication date. Products conform to specifications per the terms of Texas Instruments standard warranty. Production processing does not necessarily include testing of all parameters.

**TEXAS  
INSTRUMENTS**

POST OFFICE BOX 655303 • DALLAS, TEXAS 75265

Copyright © 1996, Texas Instruments Incorporated

**CDC9841**  
**PC MOTHERBOARD CLOCK SYNTHESIZER/DRIVER**  
**WITH 3-STATE OUTPUTS**

SCAS458D – DECEMBER 1994 – REVISED APRIL 1996

**FUNCTION TABLE**

OE	SEL0	SEL1	X1	PCLKn	BCLKn	REFn	CLK24	CLK12
L	X	X	14.31818 MHz	Hi-Z	Hi-Z	Hi-Z	Hi-Z	Hi-Z
H	L	L	14.31818 MHz	50 MHz	25 MHz	14.318 MHz	24 MHz	12 MHz
H	L	H	14.31818 MHz	60 MHz	30 MHz	14.318 MHz	24 MHz	12 MHz
H	H	L	14.31818 MHz	66 MHz	33 MHz	14.318 MHz	24 MHz	12 MHz
H	H	H	TCLK <sup>†</sup>	TCLK/2	TCLK/4	TCLK	TCLK/4	TCLK/8

<sup>†</sup> TCLK is a test clock input at the X1 input during test mode.



POST OFFICE BOX 655303 • DALLAS, TEXAS 75265

# CDC9841 PC MOTHERBOARD CLOCK SYNTHESIZER/DRIVER WITH 3-STATE OUTPUTS

SCAS458D – DECEMBER 1994 – REVISED APRIL 1996

functional block diagram

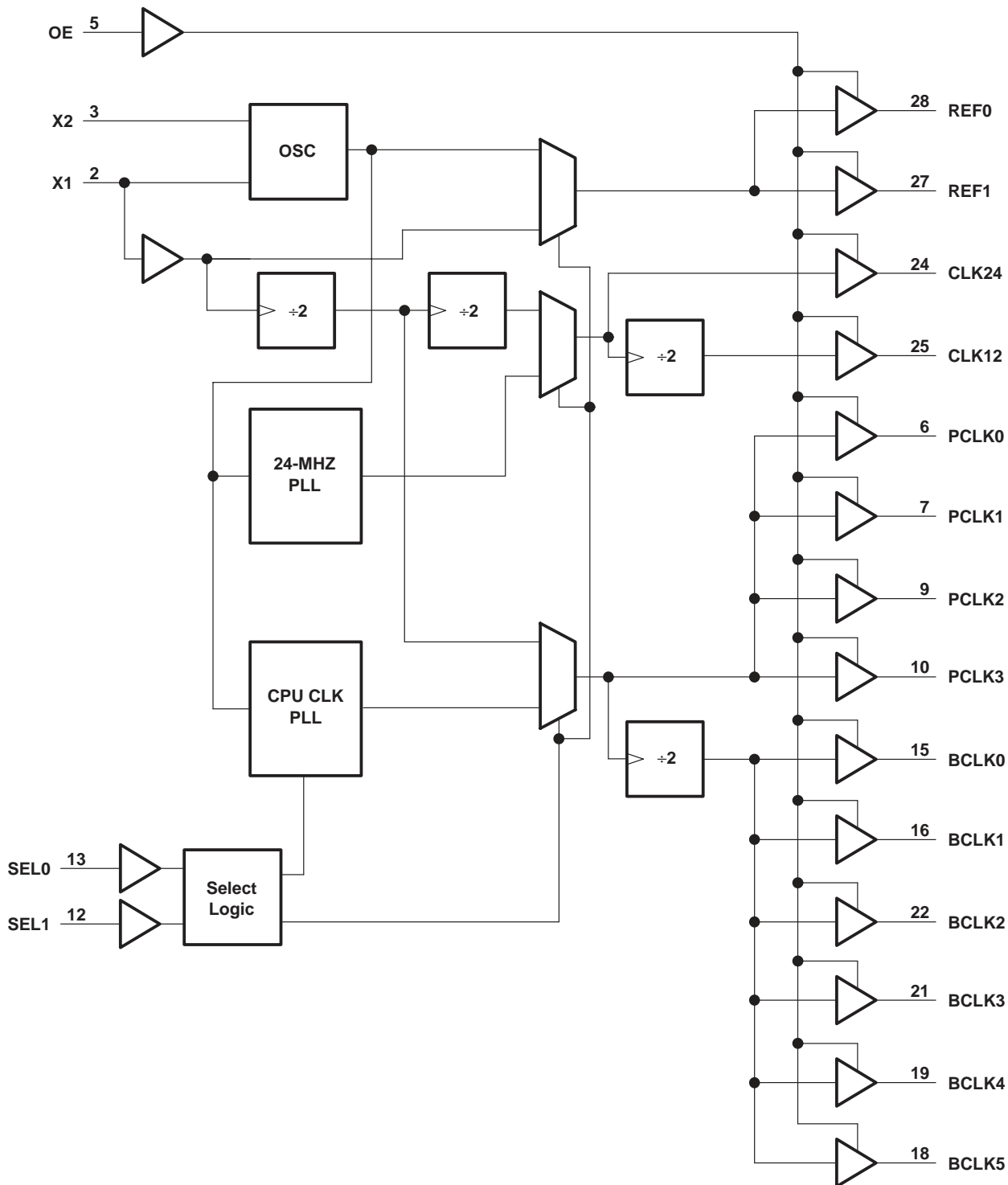

# CDC9841 PC MOTHERBOARD CLOCK SYNTHESIZER/DRIVER WITH 3-STATE OUTPUTS

SCAS458D – DECEMBER 1994 – REVISED APRIL 1996

## absolute maximum ratings over operating free-air temperature range (unless otherwise noted)†

Supply voltage range, $V_{CC}$	–0.5 V to 4.6 V
Input voltage range, $V_I$ (see Note 1)	–0.5 V to 4.6 V
Voltage range applied to any output in the high state or power-off state, $V_O$ (see Note 1)	–0.5 V to $V_{CC} + 0.5$ V
Current into any output in the low state, $I_O$	$2 \times I_{OHmax}$
Input clamp current, $I_{IK}$ ( $V_I < 0$ )	–18 mA
Output clamp current, $I_{OK}$ ( $V_O < 0$ )	–50 mA
Maximum power dissipation at $T_A = 55^\circ\text{C}$ (in still air) (see Note 2)	1.2 W
Storage temperature range, $T_{stg}$	–65°C to 150°C

† Stresses beyond those listed under “absolute maximum ratings” may cause permanent damage to the device. These are stress ratings only, and functional operation of the device at these or any other conditions beyond those indicated under “recommended operating conditions” is not implied. Exposure to absolute-maximum-rated conditions for extended periods may affect device reliability.

- NOTES: 1. The input and output negative-voltage ratings may be exceeded if the input and output clamp-current ratings are observed.  
2. The maximum package power dissipation is calculated using a junction temperature of 150°C and a board trace length of 750 mils. For more information, refer to the *Package Thermal Considerations* application note in the 1994 *ABT Advanced BiCMOS Technology Data Book*, literature number SCBD002B.

## recommended operating conditions (see Note 3)

		MIN	MAX	UNIT
$V_{CC}$	Supply voltage	3.135	3.6	V
$V_{IH}$	High-level input voltage	2		V
$V_{IL}$	Low-level input voltage		0.8	V
$V_I$	Input voltage	0	$V_{CC}$	V
$I_{OH}$	High-level output current	REF0	–12	mA
		REF1	–8	
		PCLKn	–6	
		BCLKn	–12	
		CLK24, CLK12	–4	
$I_{OL}$	Low-level output current	REF0	12	mA
		REF1	8	
		PCLKn	6	
		BCLKn	12	
		CLK24, CLK12	4	
$T_A$	Operating free-air temperature	0	70	°C

NOTE 3: Unused inputs must be held high or low to prevent them from floating.



**CDC9841**  
**PC MOTHERBOARD CLOCK SYNTHESIZER/DRIVER**  
**WITH 3-STATE OUTPUTS**

SCAS458D – DECEMBER 1994 – REVISED APRIL 1996

**electrical characteristics over recommended operating free-air temperature range (unless otherwise noted)**

PARAMETER	TEST CONDITIONS		MIN	MAX	UNIT
$V_{IK}$	$V_{CC} = 3.135\text{ V}$ ,	$I_I = -18\text{ mA}$		-1.2	V
$V_{OH}$	$V_{CC} = 3.135\text{ V}$	$I_{OH} = -12\text{ mA}$	REF0	2.5	V
		$I_{OH} = -8\text{ mA}$	REF1	2.5	
		$I_{OH} = -6\text{ mA}$	PCLKn	2.5	
		$I_{OH} = -12\text{ mA}$	BCLKn	2.5	
		$I_{OH} = -4\text{ mA}$	CLK24, CLK12	2.5	
$V_{OL}$	$V_{CC} = 3.135\text{ V}$	$I_{OL} = 12\text{ mA}$	REF0	0.4	V
		$I_{OL} = 8\text{ mA}$	REF1	0.4	
		$I_{OL} = 6\text{ mA}$	PCLKn	0.4	
		$I_{OL} = 12\text{ mA}$	BCLKn	0.4	
		$I_{OL} = 4\text{ mA}$	CLK24, CLK12	0.4	
$I_I$	$V_{CC} = 3.6\text{ V}$ ,	$V_I = V_{CC}$ or GND		$\pm 1$	$\mu\text{A}$
$I_{OZ}$	$V_{CC} = 3.6\text{ V}$ ,	$V_O = V_{CC}$ or GND		$\pm 10$	$\mu\text{A}$
$I_{CC}$	$V_{CC} = 3.6\text{ V}$ , $V_I = V_{CC}$ or GND	$I_O = 0$ ,	Outputs enabled†	50	mA
			Outputs disabled	1	
$C_i$	$V_I = V_{CC}$ or GND				pF
$C_o$	$V_O = V_{CC}$ or GND				pF
$C_{pd}$	$V_I = 3\text{ V}$ or 0				pF

† Device in normal operating mode with no load on outputs

**timing requirements over recommended ranges of supply voltage and operating free-air temperature**

		MIN	MAX	UNIT
Stabilization time‡	After SEL1, SEL0		5	ms
	After OE↑		5	
	After power up		5	

‡ Time required for the integrated PLL circuit to obtain phase lock of its feedback signal to its reference signal. In order for phase lock to be obtained, a fixed-frequency, fixed-phase reference signal must be present at X1. Until phase lock is obtained, the specifications for propagation delay and skew parameters given in the switching characteristics table are not applicable.

**CDC9841**  
**PC MOTHERBOARD CLOCK SYNTHESIZER/DRIVER**  
**WITH 3-STATE OUTPUTS**

SCAS458D – DECEMBER 1994 – REVISED APRIL 1996

**switching characteristics (see Figures 1 and 2)**

PARAMETER	FROM (INPUT)	TO (OUTPUT)	V <sub>CC</sub> = 3.135 V to 3.6 V, T <sub>A</sub> = 0°C to 70°C		UNIT
			MIN	MAX	
t <sub>skew</sub> <sup>†</sup>		PCLKn (C <sub>L</sub> = 20 pF)	200		ps
		BCLKn (C <sub>L</sub> = 30 pF)	400		
Offset <sup>†</sup>	PCLKn (C <sub>L</sub> = 20 pF)	BCLKn (C <sub>L</sub> = 30 pF)	1	4	ns
Jitter <sup>†</sup>		PCLKn (C <sub>L</sub> = 20 pF)	±250		ps
		BCLKn (C <sub>L</sub> = 30 pF)	±350		
Duty cycle <sup>†</sup>		Any output	45%	55%	
t <sub>c</sub>		PCLKn (C <sub>L</sub> = 20 pF)	SEL0 = L, SEL1 = L	20	ns
			SEL0 = L, SEL1 = H	16.7	
			SEL0 = H, SEL1 = L	15	
		BCLKn (C <sub>L</sub> = 30 pF)	SEL0 = L, SEL1 = L	40	
			SEL0 = L, SEL1 = H	33.3	
			SEL0 = H, SEL1 = L	30	
t <sub>r</sub> <sup>†‡</sup>		PCLKn (C <sub>L</sub> = 20 pF), BCLKn (C <sub>L</sub> = 30 pF)	2		ns
t <sub>f</sub> <sup>†‡</sup>		PCLKn (C <sub>L</sub> = 20 pF), BCLKn (C <sub>L</sub> = 30 pF)	2		ns

<sup>†</sup> Specifications are applicable only after the PLL stabilization time has elapsed.

<sup>‡</sup> Rise and fall times are characterized using the load circuits shown in Figure 1.



**PARAMETER MEASUREMENT INFORMATION  
 CLOCK DRIVER CIRCUITS**

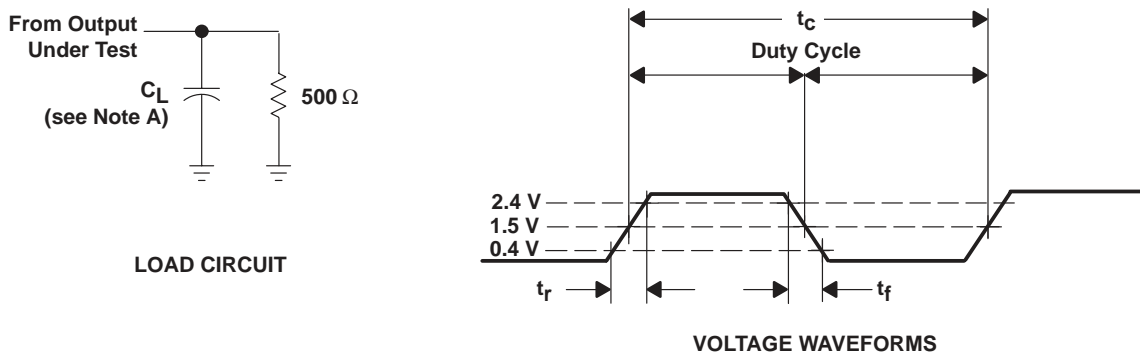

- NOTES: A.  $C_L$  includes probe and jig capacitance.  
 B. The outputs are measured one at a time with one transition per measurement.

**Figure 1. Load Circuit and Voltage Waveforms**

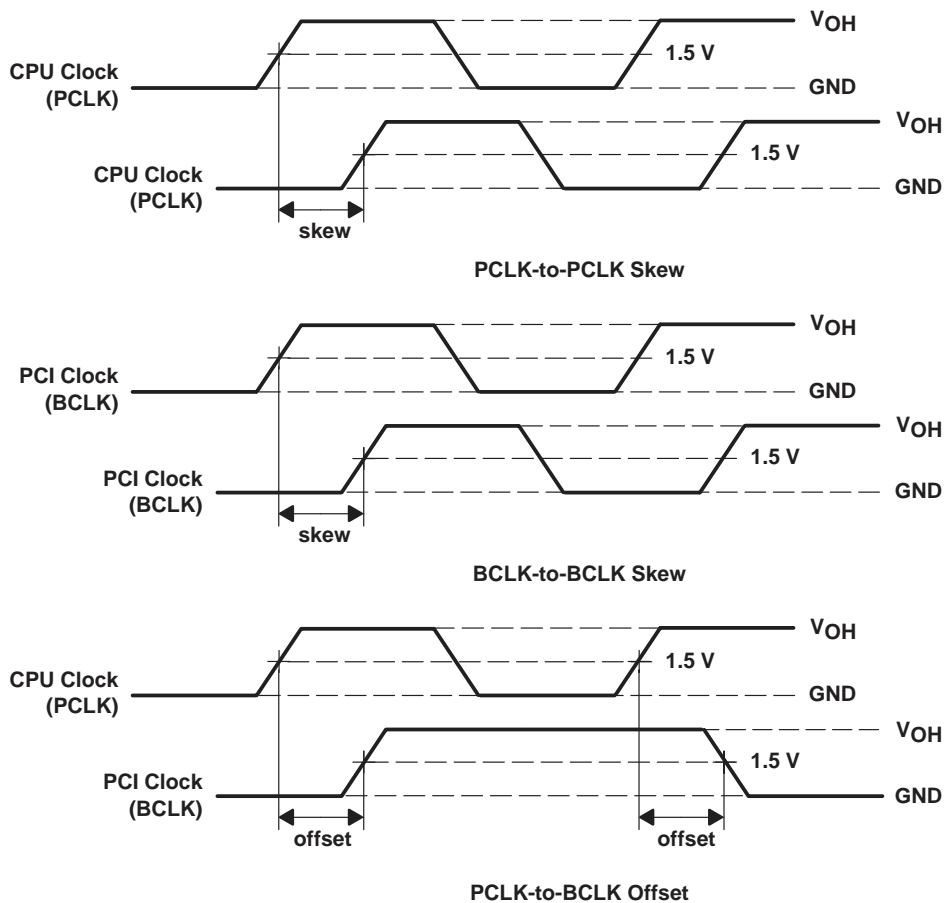

**Figure 2. Waveforms for Calculation of  $t_{skew}$  and Offset**

**PACKAGING INFORMATION**

Orderable Device	Status <sup>(1)</sup>	Package Type	Package Drawing	Pins	Package Qty	Eco Plan <sup>(2)</sup>	Lead/Ball Finish	MSL Peak Temp <sup>(3)</sup>
CDC9841DW	OBSOLETE	SOIC	DW	28		TBD	Call TI	Call TI
CDC9841DWR	OBSOLETE	SOIC	DW	28		TBD	Call TI	Call TI

<sup>(1)</sup> The marketing status values are defined as follows:

**ACTIVE:** Product device recommended for new designs.

**LIFEBUY:** TI has announced that the device will be discontinued, and a lifetime-buy period is in effect.

**NRND:** Not recommended for new designs. Device is in production to support existing customers, but TI does not recommend using this part in a new design.

**PREVIEW:** Device has been announced but is not in production. Samples may or may not be available.

**OBSOLETE:** TI has discontinued the production of the device.

<sup>(2)</sup> Eco Plan - The planned eco-friendly classification: Pb-Free (RoHS) or Green (RoHS & no Sb/Br) - please check <http://www.ti.com/productcontent> for the latest availability information and additional product content details.

**TBD:** The Pb-Free/Green conversion plan has not been defined.

**Pb-Free (RoHS):** TI's terms "Lead-Free" or "Pb-Free" mean semiconductor products that are compatible with the current RoHS requirements for all 6 substances, including the requirement that lead not exceed 0.1% by weight in homogeneous materials. Where designed to be soldered at high temperatures, TI Pb-Free products are suitable for use in specified lead-free processes.

**Green (RoHS & no Sb/Br):** TI defines "Green" to mean Pb-Free (RoHS compatible), and free of Bromine (Br) and Antimony (Sb) based flame retardants (Br or Sb do not exceed 0.1% by weight in homogeneous material)

<sup>(3)</sup> MSL, Peak Temp. -- The Moisture Sensitivity Level rating according to the JEDEC industry standard classifications, and peak solder temperature.

**Important Information and Disclaimer:**The information provided on this page represents TI's knowledge and belief as of the date that it is provided. TI bases its knowledge and belief on information provided by third parties, and makes no representation or warranty as to the accuracy of such information. Efforts are underway to better integrate information from third parties. TI has taken and continues to take reasonable steps to provide representative and accurate information but may not have conducted destructive testing or chemical analysis on incoming materials and chemicals. TI and TI suppliers consider certain information to be proprietary, and thus CAS numbers and other limited information may not be available for release.

In no event shall TI's liability arising out of such information exceed the total purchase price of the TI part(s) at issue in this document sold by TI to Customer on an annual basis.



## IMPORTANT NOTICE

Texas Instruments Incorporated and its subsidiaries (TI) reserve the right to make corrections, modifications, enhancements, improvements, and other changes to its products and services at any time and to discontinue any product or service without notice. Customers should obtain the latest relevant information before placing orders and should verify that such information is current and complete. All products are sold subject to TI's terms and conditions of sale supplied at the time of order acknowledgment.

TI warrants performance of its hardware products to the specifications applicable at the time of sale in accordance with TI's standard warranty. Testing and other quality control techniques are used to the extent TI deems necessary to support this warranty. Except where mandated by government requirements, testing of all parameters of each product is not necessarily performed.

TI assumes no liability for applications assistance or customer product design. Customers are responsible for their products and applications using TI components. To minimize the risks associated with customer products and applications, customers should provide adequate design and operating safeguards.

TI does not warrant or represent that any license, either express or implied, is granted under any TI patent right, copyright, mask work right, or other TI intellectual property right relating to any combination, machine, or process in which TI products or services are used. Information published by TI regarding third-party products or services does not constitute a license from TI to use such products or services or a warranty or endorsement thereof. Use of such information may require a license from a third party under the patents or other intellectual property of the third party, or a license from TI under the patents or other intellectual property of TI.

Reproduction of information in TI data books or data sheets is permissible only if reproduction is without alteration and is accompanied by all associated warranties, conditions, limitations, and notices. Reproduction of this information with alteration is an unfair and deceptive business practice. TI is not responsible or liable for such altered documentation.

Resale of TI products or services with statements different from or beyond the parameters stated by TI for that product or service voids all express and any implied warranties for the associated TI product or service and is an unfair and deceptive business practice. TI is not responsible or liable for any such statements.

Following are URLs where you can obtain information on other Texas Instruments products and application solutions:

<b>Products</b>		<b>Applications</b>	
Amplifiers	<a href="http://amplifier.ti.com">amplifier.ti.com</a>	Audio	<a href="http://www.ti.com/audio">www.ti.com/audio</a>
Data Converters	<a href="http://dataconverter.ti.com">dataconverter.ti.com</a>	Automotive	<a href="http://www.ti.com/automotive">www.ti.com/automotive</a>
DSP	<a href="http://dsp.ti.com">dsp.ti.com</a>	Broadband	<a href="http://www.ti.com/broadband">www.ti.com/broadband</a>
Interface	<a href="http://interface.ti.com">interface.ti.com</a>	Digital Control	<a href="http://www.ti.com/digitalcontrol">www.ti.com/digitalcontrol</a>
Logic	<a href="http://logic.ti.com">logic.ti.com</a>	Military	<a href="http://www.ti.com/military">www.ti.com/military</a>
Power Mgmt	<a href="http://power.ti.com">power.ti.com</a>	Optical Networking	<a href="http://www.ti.com/opticalnetwork">www.ti.com/opticalnetwork</a>
Microcontrollers	<a href="http://microcontroller.ti.com">microcontroller.ti.com</a>	Security	<a href="http://www.ti.com/security">www.ti.com/security</a>
		Telephony	<a href="http://www.ti.com/telephony">www.ti.com/telephony</a>
		Video & Imaging	<a href="http://www.ti.com/video">www.ti.com/video</a>
		Wireless	<a href="http://www.ti.com/wireless">www.ti.com/wireless</a>

Mailing Address: Texas Instruments  
Post Office Box 655303 Dallas, Texas 75265