

APDS-9007

Ambient Light Photo Sensor with Logarithmic Current Output



Data Sheet

Description

The APDS-9007 is an analog current output Ambient Light Photo Sensor, packaged in a miniature chipLED lead-free surface mount package.

This device provides a Logarithmic response over a wide dynamic range of 3 lux to 70K lux and has a low sensitivity variation across various light sources. It is well suited for applications that operates under high ambient brightness.

Application Support Information

The Application Engineering Group is available to assist you with the application design associated with APDS-9007 ambient light photo sensor module. You can contact them through your local sales representatives for additional details.

Features

- Excellent responsivity -
Close responsivity to the human eye
- Miniature ChipLED Leadfree surface-mount package
 - Height – 0.8 mm
 - Length – 2.4 mm
 - Width – 2.0 mm
- Low sensitivity variation across various light sources
- Operating temperature : -40°C to 85°C
- Vcc supply 2 to 3.6V
- Lead-free package with RoHS compliance
- Photo current response to wide dynamic range of 3 lux to 70K lux

Applications

- Detection of ambient light to control display backlighting
 - Mobile devices – Mobile phones, PDAs
 - Computing devices – Notebooks, Webpads
 - Consumer devices – TVs, Video Cameras, Digital Still Camera
- Automatic Residential and Commercial Lighting Management
- Electronic Signs and Signals

Ordering Information

Part Number	Packaging Type	Package	Quantity
APDS-9007-020	Tape and Reel	6-pins Chiplid package	2500

Typical Application Circuit

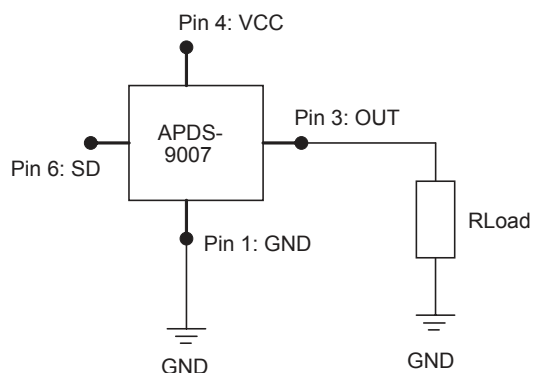

Figure 1. Typical application circuit for APDS-9007 (R_{Load} = 27 K Ohm)

I/O Pins Configuration Table

Pin	Symbol	Description
1	Gnd	Ground
2	NC *	No Connect
3	Out	Output
4	Vcc	Supply Voltage
5	NC *	No Connect
6	SD	Shutdown (Active High)

Absolute Maximum Ratings

For implementations where case to ambient thermal resistance is ± 50 °C /W

Parameter	Symbol	Min.	Max.	Units
Storage Temperature	T _S	-40	85	°C
Supply Voltage	V _{CC}	0	3.6	V

Recommended Operating Conditions

Parameter	Symbol	Min.	Max.	Units	Conditions
Operating Temperature	T _A	-40	85	°C	
Supply Voltage	V _{CC}	2	3.6	V	

CAUTION: It is advised that normal static precautions be taken in handling and assembly of this component to prevent damage and/or degradation which may be induced by ESD

Electrical & Optical Specifications (Ta=25C) :

Parameter	Symbol	Min.	Typ.	Max.	Units	Conditions
Supply Current	I _{CC}		230		μA	LUX=1K, V _{CC} =3V
Photo Current output (I)	I _{PH1}	21	30	39	uA	Lux=1K, V _{CC} =3V (Note 1,3)
Photo Current output (II)	I _{PH2}		36			Lux=1K, V _{CC} =3V (Note 2,3)
Light Current Ratio	I _{PH2} /I _{PH1}		1.2			
Rise Time	Tr		0.2		mSec	Rload = 27K ohms, 1K lux, V _{CC} = 3V
Fall Time	Tf		0.2		mSec	Rload = 27K ohms, 1K lux, V _{CC} = 3V
Peak sensitivity wavelength	λ		560		nm	
SD Current	I _{CC-SD}			1	μA	V _{CC} =3V, SD=3V
Output Compliance Voltage	V _{out}	V _{CC} -0.5			Volts	RLoad=100K, V _{CC} =3V (Refer Figure 7)

Notes :

1. White LED is used as light source
2. Illuminance by incandescent lamp
3. Photo Current (I out) = 10uA x Log (Lux)

Functional Block Diagram

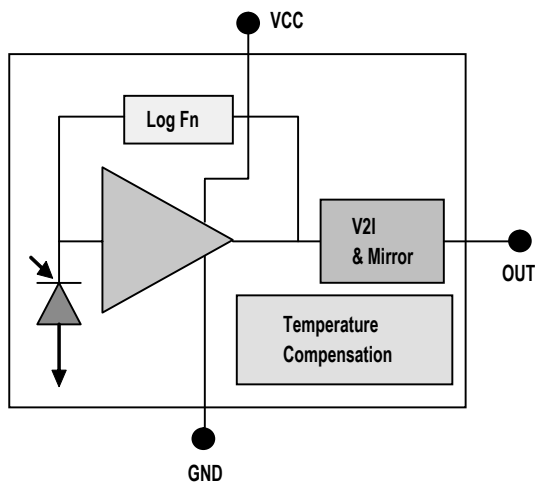

Light Measurement Circuit and Waveforms

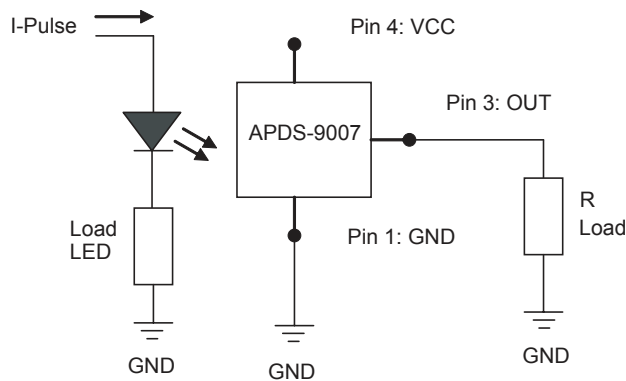

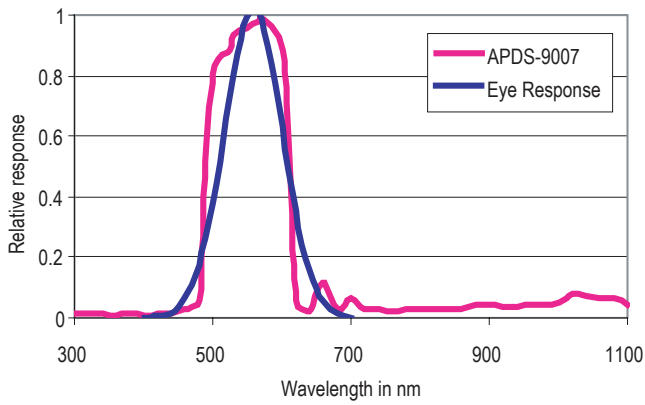

Figure 1. Spectral Response

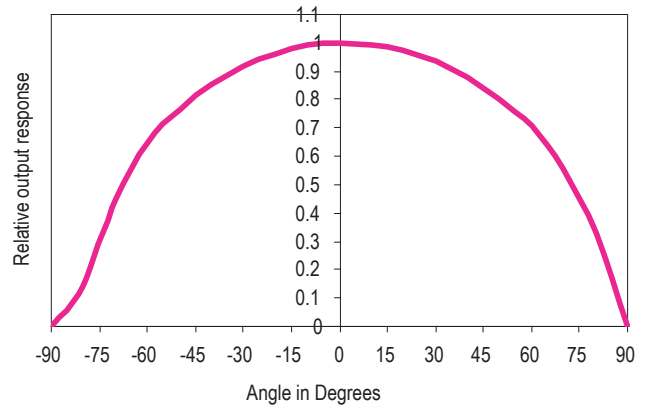

Figure 2. Angular Response plot

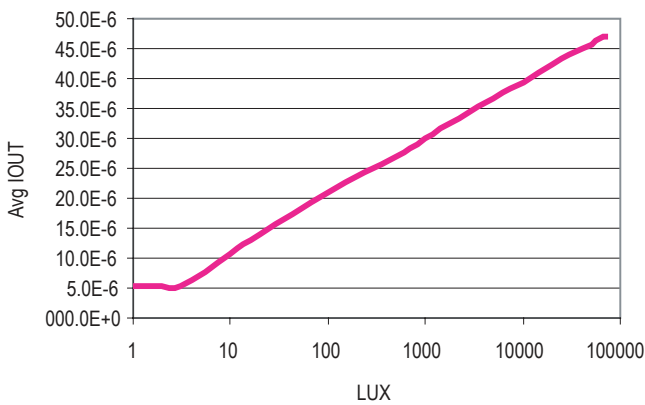

Figure 3. Average Iout vs Lux, T=25°C

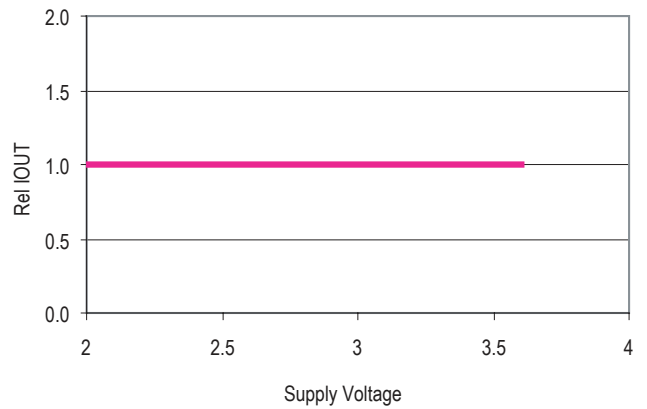

Figure 4. Relative Iout Vs Vcc @ 1K LUX, T=25°C

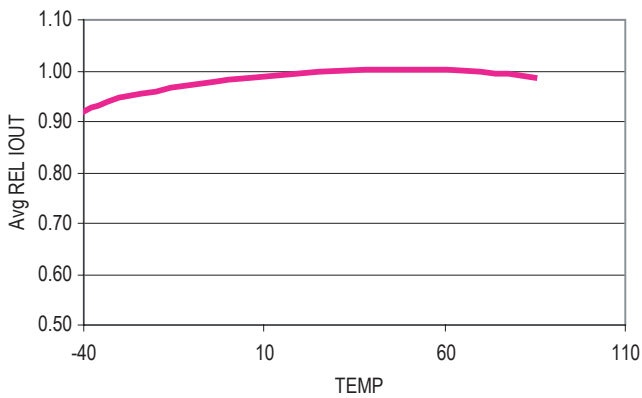

Figure 5. Relative Iout Vs Temperature

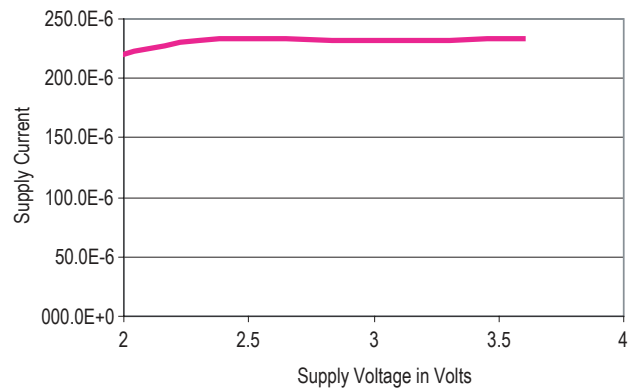

Figure 6. Icc Vs Vcc, T=25°C

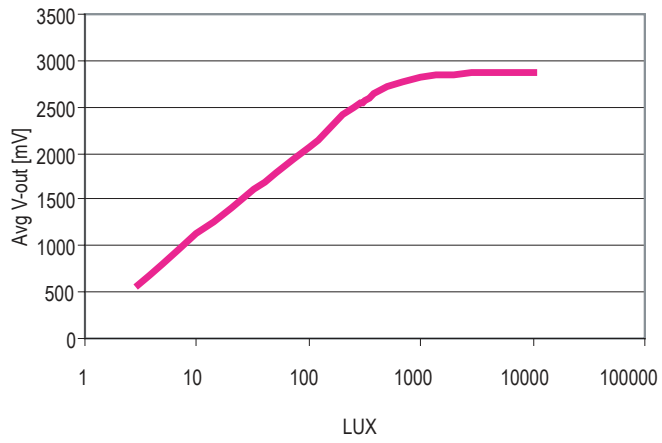

Figure 7. Output Compliance Voltage plot

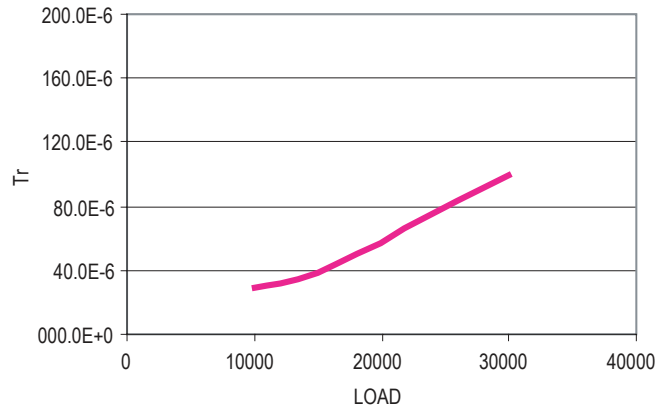

Figure 8. Rise Time Vs RLoad (Ohm)

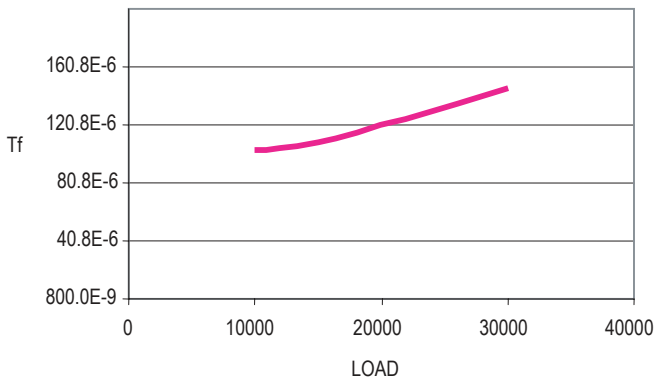

Figure 9. Fall Time Vs RLoad(Ohm)

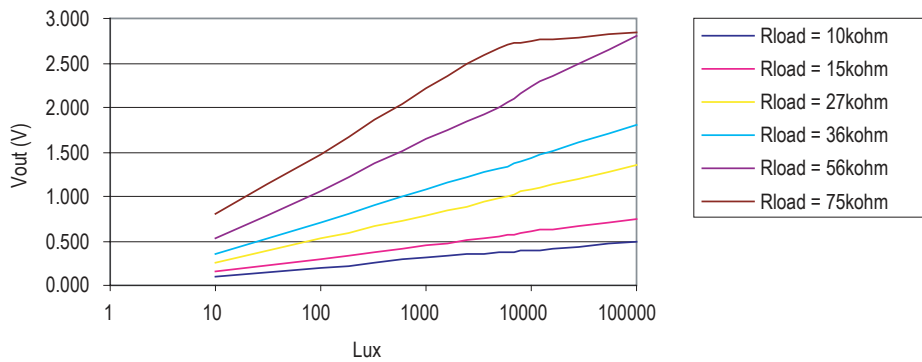
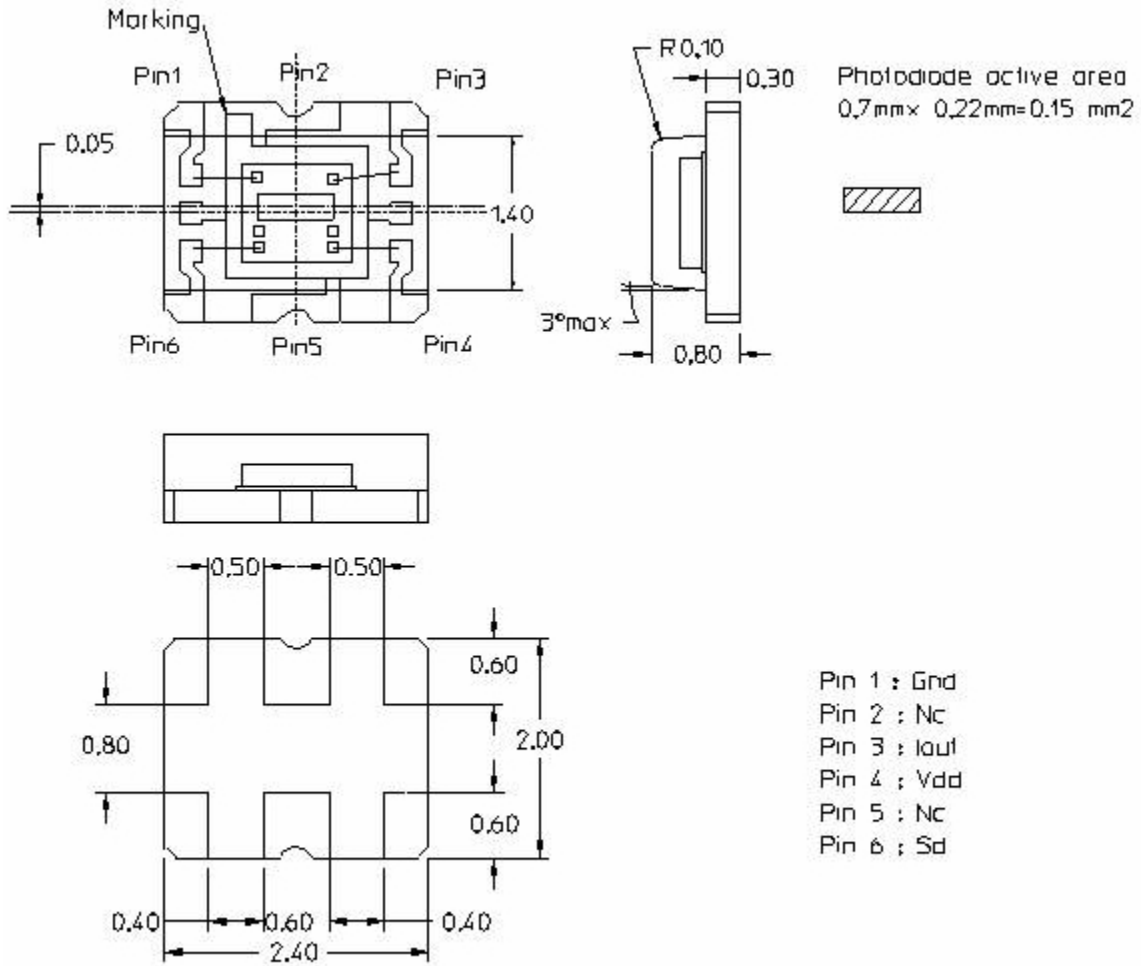

Figure 10. Average Vout vs Lux

APDS-9007 Package Outline



- Pin 1 : Gnd
- Pin 2 : Nc
- Pin 3 : Iout
- Pin 4 : Vdd
- Pin 5 : Nc
- Pin 6 : Sd

Tolerance $\pm 0.1\text{mm}$

Note: Active Area : Center of the device

APDS-9007 Tape and Reel Dimension

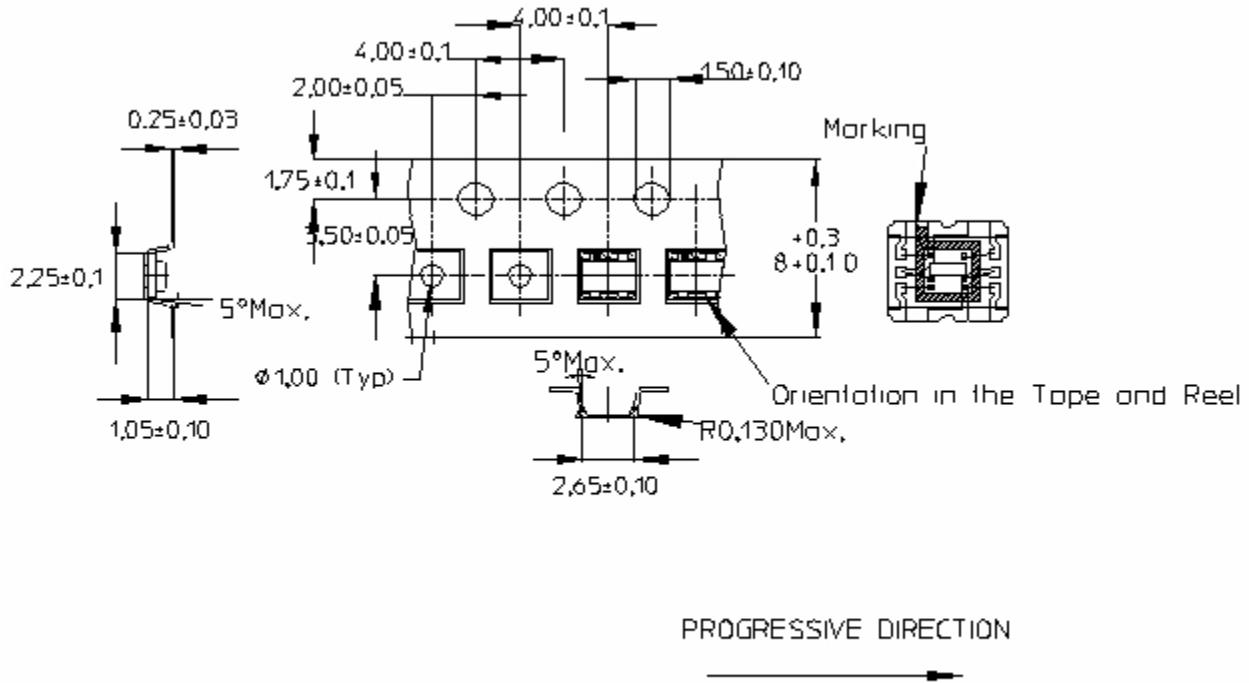

Material of Carrier Tape : Conductive Polystyrene
 Material of Cover Tape : PVC
 Method of Cover : Heat Sensitive Adhesive

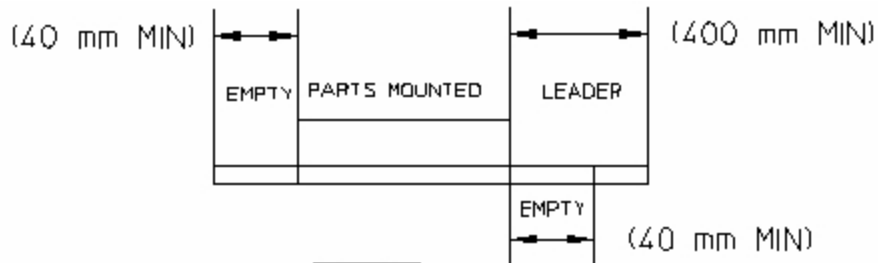

"B"	"C"
178	75

UNIT : mm

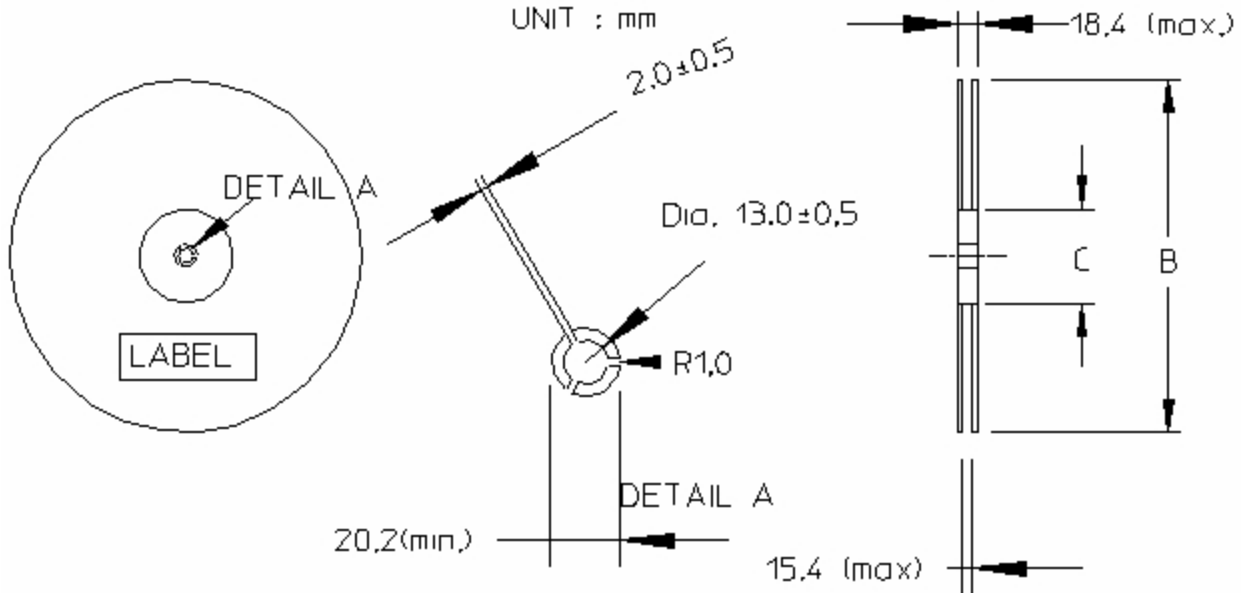

Moisture Proof Packaging

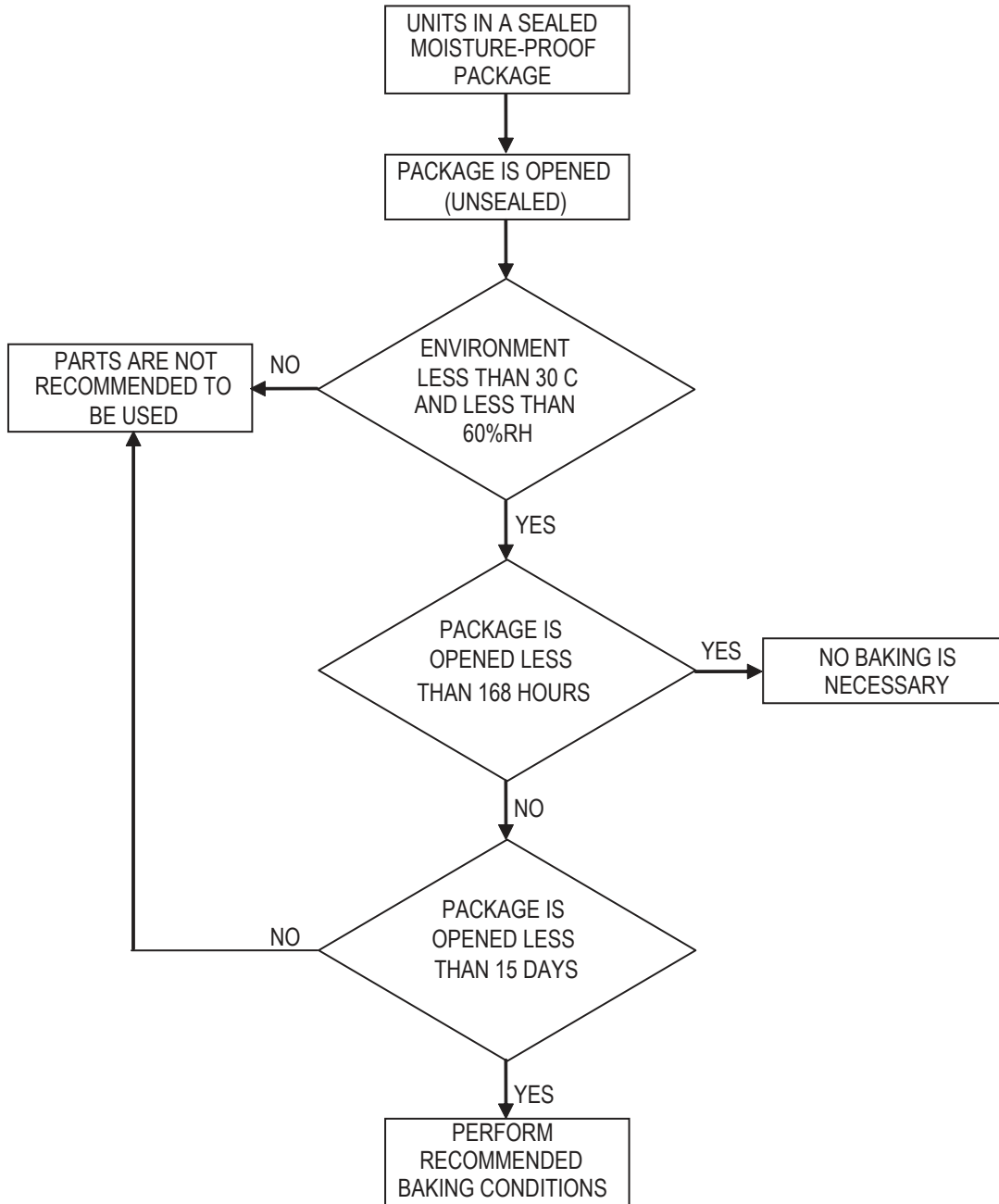

All APDS-9007 options are shipped in moisture proof package. Once opened, moisture absorption begins. This part is compliant to JEDEC Level 3.

Baking Conditions:

Package	Temperature	Time
In Reel	60°C	48 hours
In Bulk	100°C	6 hours

* Baking should only be done once.

Recommended Storage Conditions:

Storage Temperature 10°C to 30°C
 Relative Humidity below 60% RH

Time from unsealing to soldering:

After removal from the bag, the parts should be soldered within 168 hours if stored at the recommended storage conditions. If times longer than 168 hours are needed, the parts must be stored in a dry box.

Recommended Reflow Profile

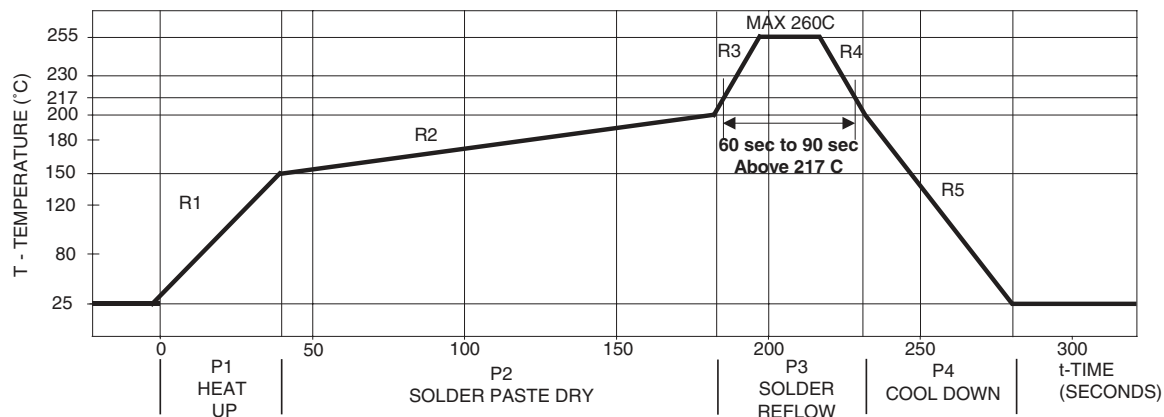

Process Zone	Symbol	ΔT	Maximum $\Delta T/\Delta \text{time}$ or Duration
Heat Up	P1, R1	25°C to 150°C	3°C/s
Solder Paste Dry	P2, R2	150°C to 200°C	100s to 180s
Solder Reflow	P3, R3 P3, R4	200°C to 260°C	3°C/s
		260°C to 200°C	-6°C/s
Cool Down	P4, R5	200°C to 25°C	-6°C/s
Time maintained above liquidus point , 217°C		> 217°C	60s to 90s
Peak Temperature		260°C	-
Time within 5°C of actual Peak temperature		>255°C	20s to 40s
Time 25°C to Peak Temperature		25°C to 260°C	8mins

The reflow profile is a straight-line representation of a nominal temperature profile for a convective reflow solder process. The temperature profile is divided into four process zones, each with different $\Delta T/\Delta \text{time}$ temperature change rates or duration. The $\Delta T/\Delta \text{time}$ rates or duration are detailed in the above table. The temperatures are measured at the component to printed circuit board connections.

In process zone P1, the PC board and component pins are heated to a temperature of 150°C to activate the flux in the solder paste. The temperature ramp up rate, R1, is limited to 3°C per second to allow for even heating of both the PC board and component pins.

Process zone P2 should be of sufficient time duration (100 to 180 seconds) to dry the solder paste. The temperature is raised to a level just below the liquidus point of the solder.

Process zone P3 is the solder reflow zone. In zone P3, the temperature is quickly raised above the liquidus point of solder to 260°C (500°F) for optimum results. The dwell time above the liquidus point of solder should be between 60 and 90 seconds. This is to assure proper coalescing of the solder paste into liquid solder and the formation of good solder connections. Beyond the recommended dwell time the intermetallic growth within the solder connections becomes excessive, resulting in the formation of weak and unreliable connections. The temperature is then rapidly reduced to a point below the solidus temperature of the solder to allow the solder within the connections to freeze solid.

Process zone P4 is the cool down after solder freeze. The cool down rate, R5, from the liquidus point of the solder to 25°C (77°F) should not exceed 6°C per second maximum. This limitation is necessary to allow the PC board and component pins to change dimensions evenly, putting minimal stresses on the component.

It is recommended to perform reflow soldering no more than twice.

Appendix A: SMT Assembly Application Note

1.0 Solder Pad, Mask and Metal Stencil Aperture

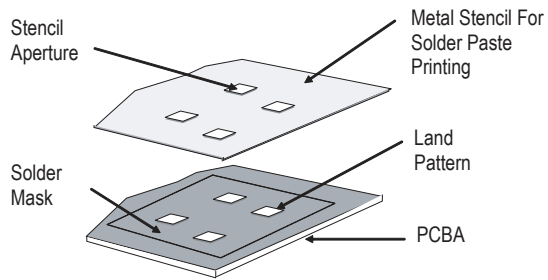

Figure A1. Stencil and PCBA

1.1 Recommended Land Pattern

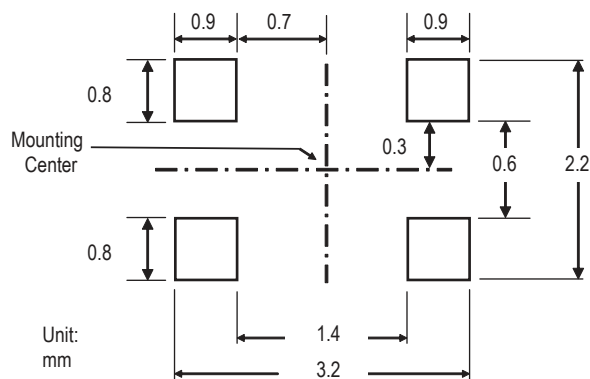

Figure A2. Recommended Land Pattern

1.2 Recommended Metal Solder Stencil Aperture

It is recommended that a 0.11 mm (0.004 inches) thick stencil be used for solder paste printing. Aperture opening for shield pad is 0.9mm x 0.8mm (as per land pattern). This is to ensure adequate printed solder paste volume and no shorting.

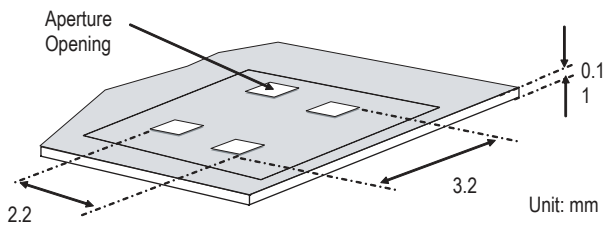

Figure A3. Solder Stencil Aperture

1.3 Adjacent Land Keepout and Solder Mask Areas

Adjacent land keep-out is the maximum space occupied by the unit relative to the land pattern. There should be no other SMD components within this area.

The minimum solder resist strip width required to avoid solder bridging adjacent pads is 0.2 mm.

Note: Wet/Liquid Photo-Imageable solder resist/mask is recommended.

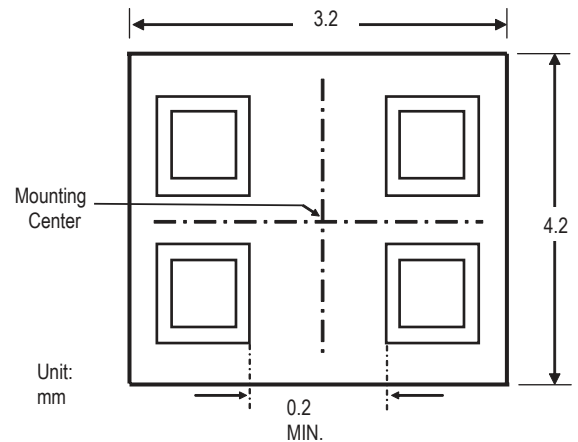

Figure A4. Adjacent Land Keepout and Solder Mask Areas

Appendix B: Optical Window Design for APDS-9007

1.0 Optical Window Dimensions

To ensure that the performance of the APDS-9007 will not be affected by improper window design, there are some constraints on the dimensions and design of the window. There is a constraint on the minimum size of the window, which is placed in front of the photo light sensor, so that it will not affect the angular response of the APDS-9007. This minimum dimension that is recommended will ensure at least a $\pm 35^\circ$ light reception cone.

If a smaller window is required, a light pipe or light guide can be used. A light pipe or light guide is a cylindrical piece of transparent plastic, which makes use of total internal reflection to focus the light.

The thickness of the window should be kept as minimum as possible because there is a loss of power in every optical window of about 8% due to reflection (4% on each side) and an additional loss of energy in the plastic material.

Figure B1 and B2 illustrate the two types of window that we have recommended which could either be a flat window or a flat window with light pipe.

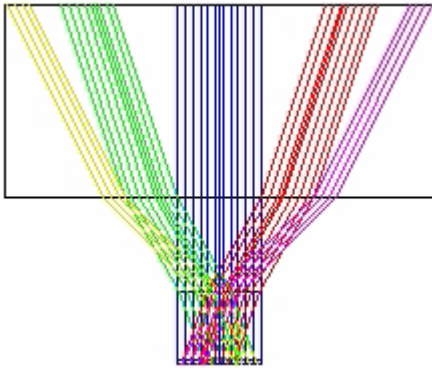

Figure B1. Window Size Determination for Flat Window

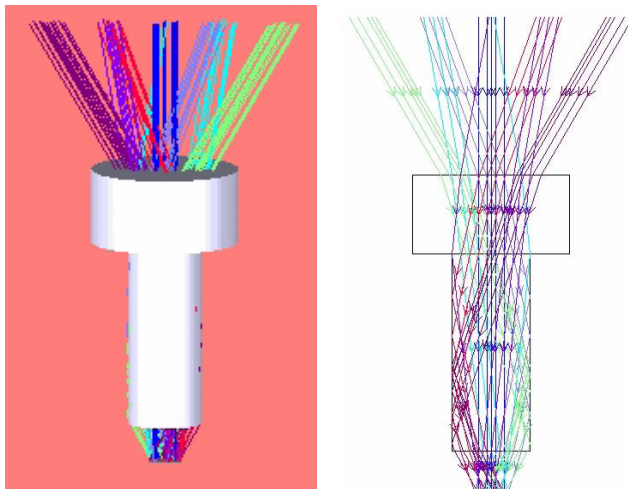

Figure B2. Window Design of Flat Window with Light Guide

Table 1 and Figure B3 below show the recommended dimensions of the window. These dimension values are based on a window thickness of 1.0mm with a refractive index 1.585.

Table 1. Recommended minimum dimension for optical window. All dimensions are in mm

WD (T+L+Z)	Flat Window (L=0.0)		Flat window with Light Pipe	
	Z	D1	D1/D2	T/L/Z
1.5	0.5	2.15	-	-
2.0	1.0	2.85	-	-
2.5	1.5	3.55	-	-
3.0	2.0	4.25	2.0/1.2	1.0/1.5/0.5

The window should be placed directly on top of the light receiving area (active area) of the photo sensor to achieve better performance and if a flat window with a light pipe is used, dimension D2 should be 1.5mm to optimize the performance of APDS-9007.

The recommended minimum window dimension is based on the assumption that the center of the window and the center of the light receiving of the photo sensor are the same. It is recommended that the tolerance for assembly be considered as well. The recommended minimum window size which will take into account of the assembly tolerance is defined as:

$$D1 \text{ (min + assembly tolerance)} = D1_{\text{min}} + 2 * (\text{assembly tolerance}) \text{ (Dimensions are in mm)}$$

$$D2 \text{ (min + assembly tolerance)} = D2_{\text{min}} + 2 * (\text{assembly tolerance}) \text{ (Dimensions are in mm)}$$

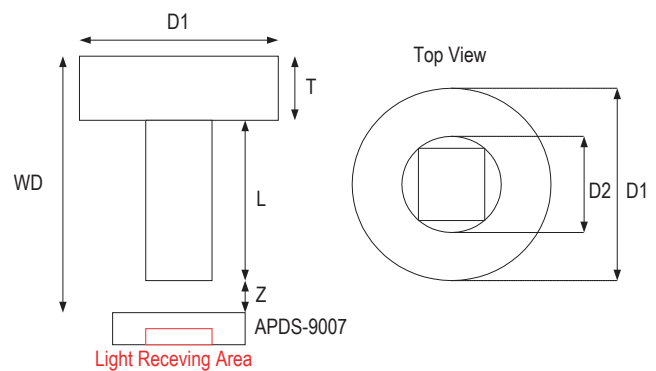

- WD: Working Distance between window front panel & APDS-9007
- D1: Window Diameter
- T: Thickness
- L: Length of Light Pipe
- D2: Light Pipe Diameter
- Z: Distance between window rear panel and APDS-9007

Figure B3 .Recommended Window Dimensions

2.1 Optical Window Material

The material of the window is recommended to be polycarbonate. The surface finish of the plastic should be smooth, without any texture.

The recommended plastic material for use as a window is available from Bayer AG and Bayer Antwerp N. V. (Europe), Bayer Corp.(USA) and Bayer Polymers Co., Ltd. (Thailand), as shown in Table 2.

Table 2. Recommended Plastic Materials

Material number	Visible light transmission	Refractive index
Makrolon LQ2647	87%	1.587
Makrolon LQ3147	87%	1.587
Makrolon LQ3187	85%	1.587

Appendix C: General Application Guide for APDS-9007

The APDS-9007 is an analog current output ambient light photo sensor whose spectral response is close to the CIE standard photopic observer. APDS-9007 consists of a photodiode and an IC that performs amplification of the photodiode output signal and conversion to a logarithmic output current. APDS-9007 is able to produce a high gain photo current that can be converted to an output voltage via a standard value external load resistor. APDS-9007 is then easily integrated into micro-controller that has an available A/D as shown in Figure C1 below.

The magnitude of the output voltage, V_{out} is directly proportional to the photo current which is generated by the brightness of the light source shone on the photo sensor and the value of the load resistor used, R_L . Increasing the brightness of the light source and/or the value of the load resistor will increase the magnitude of the output voltage.

The unit used to measure light in terms of what our eyes perceive is "LUX". It indicates the intensity to which a surface is lit or the brightness of the light. Light sources with the same LUX level appear at the same brightness to the human eyes. The equipment for "LUX" measurement is a lux meter.

Selection of the load resistor R_L will determine the amount of current-to-voltage conversion in the circuit. APDS-9007 allows a maximum saturation output voltage of $(V_{cc} - 0.5V)$.

Artificial light sources such as fluorescent lamps or incandescent lamps produced ac noise with a frequency of 50/60Hz and 100Hz respectively. A capacitor of 10uF, which acts as a low-pass filter, is recommended to be added in parallel with the load resistor to filter out these interferences.

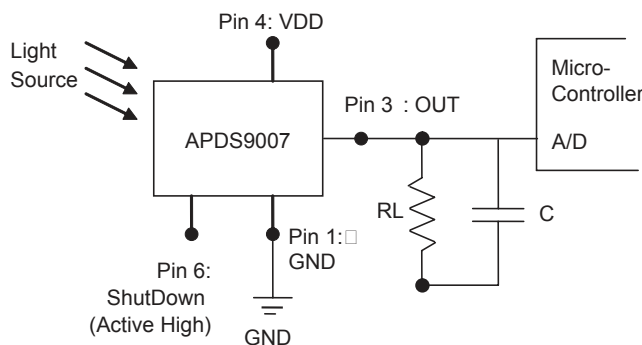

Figure C1. Configuration of APDS-9007

An analog logarithmic current output is able to represent the wide dynamic range of ambient light brightness level from near darkness environment to bright outdoor conditions correctly and accurately. For a logarithmic output, constant relative changes in the input values are converted to constant absolute changes in the output values.

A logarithmic current output is advantageous because when measuring low brightness levels, small changes in those levels need to be detected. For example, a change from 100lux to 200lux needs to be detected. On the other hand, when measuring high brightness levels, only relatively large changes need to be detected. For example, a change from 10000lux to 10200lux can be negligible and a change from 10klux to 20klux needs to be detected instead.

Hence APDS-9007, with a logarithmic current output, is able to provide a good relative resolution over the entire ambient light brightness range. It is able to measure small current steps at low brightness levels and yet, at high brightness levels, it is not required to measure the current at such fine absolute resolutions.

This is illustrated in Figure C2 below. A change from 10lux to 100lux and a change from 1klux to 10klux will both give a same relative change which is 10. This is equivalent to a constant absolute change in output current which is 10uA for both changes. Hence a change from 10lux to 100lux will result in a change of 10uA. Similarly, a change from 1klux to 10klux will also result in a change of 10uA.

APDS-9007 can be directly connected to the A/D of the micro-controller via one external load resistor which will give the same accuracy or resolution over a wide dynamic range.

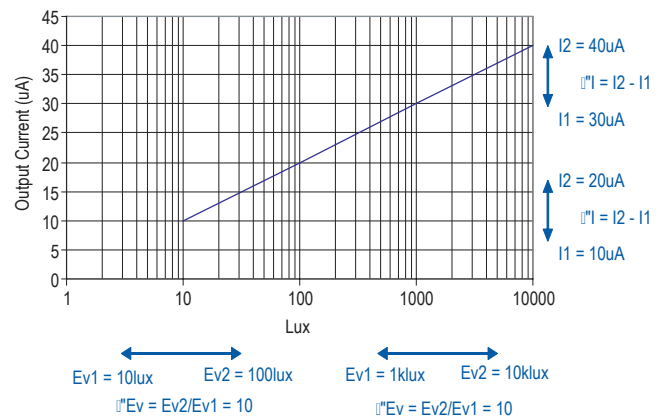

Figure C2. Feature of Logarithmic Output

For product information and a complete list of distributors, please go to our web site: **www.avagotech.com**

Avago, Avago Technologies, and the A logo are trademarks of Avago Technologies, Limited in the United States and other countries.
Data subject to change. Copyright © 2007 Avago Technologies Limited. All rights reserved.

AV02-0512EN - June 28, 2007