

TPS54628 4.5-V to 18-V Input, 6-A Synchronous Step-Down Converter With Eco-Mode™

1 Features

- D-CAP2™ Mode Enables Fast Transient Response
- Low-Output Ripple and Allows Ceramic Output Capacitor
- Wide V_{IN} Input Voltage Range: 4.5 V to 18 V
- Output Voltage Range: 0.76 V to 5.5 V
- Highly Efficient Integrated FETs Optimized for Lower Duty-Cycle Applications
 - 36 m Ω (High-Side) and 28 m Ω (Low-Side)
- High Efficiency, Less Than 10 μ A at Shutdown
- High Initial Band-Gap Reference Accuracy
- Adjustable Soft Start
- Prebiased Soft Start
- 650-kHz Switching Frequency (f_{sw})
- Cycle-by-Cycle Overcurrent Limit
- Auto-Skip Eco-Mode™ for High Efficiency at Light Load

2 Applications

- Wide Range of Applications for Low-Voltage Systems:
 - Digital-TV Power Supplies
 - High-Definition Blu-Ray Disc™ Players
 - Networking Home Terminals
 - Digital Set-Top Boxes (STBs)

3 Description

The TPS54628 device is an adaptive on-time D-CAP2 mode synchronous-buck converter. The TPS54628 enables system designers to complete the suite of various end-equipment power-bus regulators with a cost-effective, low-component count, low-standby current solution.

The main control loop for the TPS54628 uses the D-CAP2 mode control that provides a fast transient response with no external compensation components. The adaptive on-time control supports seamless transition between PWM mode at higher load conditions and Eco-Mode operation at light loads. Eco-Mode allows the TPS54628 to maintain high efficiency during lighter load conditions. The TPS54628 also has a proprietary circuit that enables the device to adopt to both low equivalent-series-resistance (ESR) output capacitors, such as POSCAP or SP-CAP, and ultra-low ESR ceramic capacitors.

The device operates from 4.5-V to 18-V V_{IN} input. The output voltage can be programmed between 0.76 V and 5.5 V. The device also features an adjustable soft-start time. The TPS54628 is available in the 8-pin SO PowerPAD package, and designed to operate from -40°C to 85°C .

Device Information⁽¹⁾

PART NUMBER	PACKAGE	BODY SIZE (NOM)
TPS54628	SO PowerPAD (8)	4.89 mm × 3.90 mm

(1) For all available packages, see the orderable addendum at the end of the data sheet.

Simplified Schematic

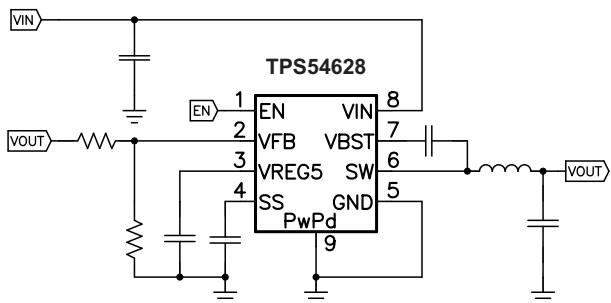

Copyright © 2016, Texas Instruments Incorporated

Load Transient Response

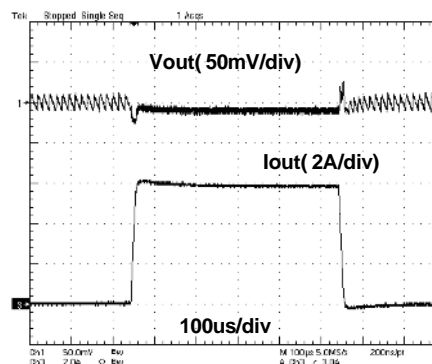

Table of Contents

1 Features	1	8 Application and Implementation	12
2 Applications	1	8.1 Application Information.....	12
3 Description	1	8.2 Typical Application	12
4 Revision History	2	9 Power Supply Recommendations	15
5 Pin Configuration and Functions	3	10 Layout	16
6 Specifications	4	10.1 Layout Guidelines	16
6.1 Absolute Maximum Ratings	4	10.2 Layout Example	16
6.2 ESD Ratings	4	10.3 Thermal Considerations	17
6.3 Recommended Operating Conditions.....	4	11 Device and Documentation Support	18
6.4 Thermal Information	5	11.1 Documentation Support	18
6.5 Electrical Characteristics – DC	5	11.2 Receiving Notification of Documentation Updates	18
6.6 Typical Characteristics.....	7	11.3 Community Resources.....	18
7 Detailed Description	9	11.4 Trademarks	18
7.1 Overview	9	11.5 Electrostatic Discharge Caution.....	18
7.2 Functional Block Diagram	9	11.6 Glossary	18
7.3 Feature Description.....	10	12 Mechanical, Packaging, and Orderable	18
7.4 Device Functional Modes.....	11	Information	18

4 Revision History

NOTE: Page numbers for previous revisions may differ from page numbers in the current version.

Changes from Original (April 2013) to Revision A	Page
• Added <i>Pin Configuration and Functions</i> section, <i>ESD Ratings</i> table, <i>Feature Description</i> section, <i>Device Functional Modes</i> , <i>Application and Implementation</i> section, <i>Power Supply Recommendations</i> section, <i>Layout</i> section, <i>Device and Documentation Support</i> section, and <i>Mechanical, Packaging, and Orderable Information</i> section	1
• Deleted <i>Ordering Information</i> table; see <i>Package Option Addendum</i> at the end of the data sheet.....	1

5 Pin Configuration and Functions

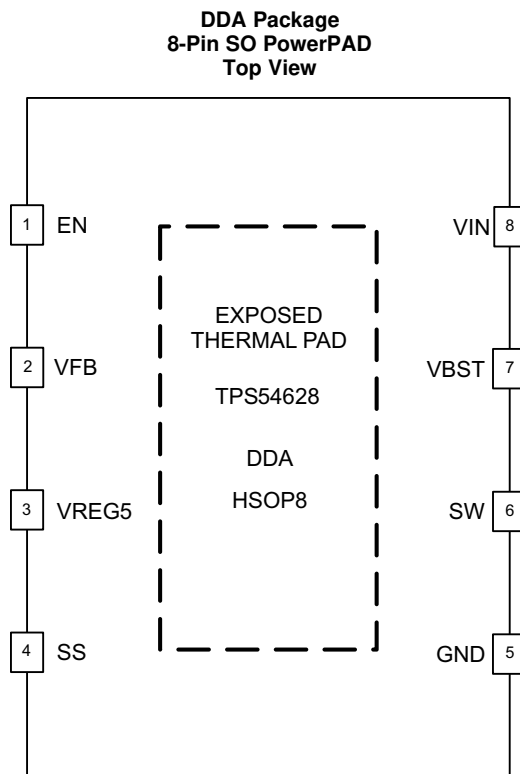

Pin Functions

PIN		I/O	DESCRIPTION
NO.	NAME		
1	EN	I	Enable input control. EN is active high and must be pulled up to enable the device.
2	VFB	I	Converter feedback input. Connect to output voltage with feedback resistor divider.
3	VREG5	O	5.5-V power supply output. A capacitor (typically 1 μ F) must be connected to GND. VREG5 is not active when EN is low.
4	SS	I	Soft-start control. An external capacitor must be connected to GND.
5	GND	—	Ground pin. Power ground return for switching circuit. Connect sensitive SS and VFB returns to GND at a single point.
6	SW	O	Switch node connection between high-side NFET and low-side NFET.
7	VBST	O	Supply input for the high-side FET gate drive circuit. Connect 0.1- μ F capacitor between VBST and SW pins. An internal diode is connected between VREG5 and VBST.
8	VIN	I	Input voltage supply pin.
—	Exposed Thermal Pad	—	Thermal pad of the package. Must be soldered to achieve appropriate dissipation. Must be connected to GND.

6 Specifications

6.1 Absolute Maximum Ratings

 See ⁽¹⁾

		MIN	MAX	UNIT
Input voltage	VIN, EN	–0.3	20	V
	VBST	–0.3	26	
	VBST (10-ns transient)	–0.3	28	
	VBST (vs SW)	–0.3	6.5	
	VFB, SS	–0.3	6.5	
	SW	–2	20	
	SW (10-ns transient)	–3	22	
Output voltage	VREG5	–0.3	6.5	V
	GND	–0.3	0.3	
Voltage from GND to thermal pad, V_{diff}		–0.2	0.2	V
Operating junction temperature, T_J		–40	150	°C
Storage temperature, T_{stg}		–55	150	°C

(1) Stresses beyond those listed under *Absolute Maximum Ratings* may cause permanent damage to the device. These are stress ratings only, and functional operation of the device at these or any other conditions beyond those indicated under *Recommended Operating Conditions* is not implied. Exposure to absolute-maximum-rated conditions for extended periods may affect device reliability.

6.2 ESD Ratings

		VALUE	UNIT
$V_{(ESD)}$ Electrostatic discharge	Human-body model (HBM) ⁽¹⁾	±2000	V
	Charged-device model (CDM)	±500	

(1) AEC Q100-002 indicates that HBM stressing shall be in accordance with the ANSI/ESDA/JEDEC JS-001 specification.

6.3 Recommended Operating Conditions

		MIN	MAX	UNIT
V_{IN}	Supply input voltage	4.5	18	V
Input voltage	VBST	–0.1	24	V
	VBST (10-ns transient)	–0.1	27	
	VBST (vs SW)	–0.1	6	
	SS	–0.1	5.7	
	EN	–0.1	18	
	VFB	–0.1	5.5	
	SW	–1.8	18	
	SW (10-ns transient)	–3	21	
	GND	–0.1	0.1	
V_O	Output voltage (VREG5)	–0.1	5.7	V
I_O	Output current (I_{VREG5})	0	5	mA
T_A	Operating free-air temperature	–40	85	°C
T_J	Operating junction temperature	–40	150	°C

6.4 Thermal Information

THERMAL METRIC ⁽¹⁾		TPS54628	
		DDA (SO PowerPAD)	
		8 PINS	
			UNIT
R _{θJA}	Junction-to-ambient thermal resistance	43.5	°C/W
R _{θJC(top)}	Junction-to-case (top) thermal resistance	49.4	°C/W
R _{θJB}	Junction-to-board thermal resistance	25.6	°C/W
Ψ _{JT}	Junction-to-top characterization parameter	7.4	°C/W
Ψ _{JB}	Junction-to-board characterization parameter	25.5	°C/W
R _{θJC(bot)}	Junction-to-case (bottom) thermal resistance	5.2	°C/W

(1) For more information about traditional and new thermal metrics, see the [Semiconductor and IC Package Thermal Metrics](#) application report.

6.5 Electrical Characteristics – DC

Over operating free-air temperature range and V_{IN} = 12 V (unless otherwise noted)

PARAMETER		TEST CONDITIONS	MIN	TYP	MAX	UNIT
SUPPLY CURRENT						
I _{VIN}	Operating non-switching supply current	V _{IN} current, T _A = 25°C, EN = 5 V, V _{F_B} = 0.8 V		950	1400	μA
I _{VINSDN}	Shutdown supply current	V _{IN} current, T _A = 25°C, EN = 0 V		3	10	μA
LOGIC THRESHOLD						
V _{EN}	EN high-level input voltage	EN	1.6			V
	EN low-level input voltage	EN			0.6	
R _{EN}	EN pin resistance to GND	V _{EN} = 12 V	200	400	800	kΩ
V_{F_B} VOLTAGE AND DISCHARGE RESISTANCE						
V _{F_BTH}	V _{F_B} threshold voltage	T _A = 25°C, V _O = 1.05 V, I _O = 10 mA, Eco-Mode operation		772		mV
		T _A = 25°C, V _O = 1.05 V, continuous mode operation	757	765	773	mV
		T _A = -40 to 85°C, V _O = 1.05 V, continuous mode operation ⁽¹⁾	751	765	779	mV
I _{V_{F_B}}	V _{F_B} input current	V _{F_B} = 0.8 V, T _A = 25°C		0	±0.15	μA
V_{REG5} OUTPUT						
V _{V_{REG5}}	V _{REG5} output voltage	T _A = 25°C, 6 V < V _{IN} < 18 V, 0 < I _{V_{REG5}} < 5 mA	5.2	5.5	5.7	V
I _{V_{REG5}}	Output current	V _{IN} = 6 V, V _{REG5} = 4 V, T _A = 25°C		20		mA
V_{OUT} DISCHARGE						
R _{DISCHG}	V _{OUT} discharge resistance	EN = 0 V, SW = 0.5 V, T _A = 25°C		500	800	Ω
MOSFET						
R _{DS(on)}	High-side switch resistance	25°C, V _{BST} – SW = 5.5 V		36		mΩ
	Low-side switch resistance	25°C		28		
CURRENT LIMIT						
I _{OCL}	Current limit	L out = 1.5 μH ⁽¹⁾	6.7	7.3	8.9	A
THERMAL SHUTDOWN						
T _{SDN}	Thermal shutdown threshold ⁽¹⁾	Shutdown temperature		165		°C
		Hysteresis		35		
ON-TIME TIMER CONTROL						
t _{ON}	ON time	V _{IN} = 12 V, V _O = 1.05 V		150		ns
t _{OFF(MIN)}	Minimum OFF time	T _A = 25°C, V _{F_B} = 0.7 V		260	310	ns

(1) Not production tested.

Electrical Characteristics – DC (continued)

 Over operating free-air temperature range and $V_{IN} = 12\text{ V}$ (unless otherwise noted)

PARAMETER		TEST CONDITIONS	MIN	TYP	MAX	UNIT
SOFT START						
I_{SS}	SS charge current	$V_{SS} = 1\text{ V}$	4.2	6	7.8	μA
	SS discharge current	$V_{SS} = 0.5\text{ V}$	1.5	3.3		mA
HICCUP AND OVERVOLTAGE PROTECTION						
V_{OVP}	Output OVP threshold	OVP Detect ($L > H$)	125%			
V_{HICCUP}	Output hiccup threshold	Hiccup detect ($H > L$)	65%			
$T_{HICCUPDELAY}$	Output hiccup delay	To hiccup state	250			μs
$T_{HICCUPENDELAY}$	Output hiccup enable delay	Relative to soft-start time	$\times 1.7$			
UVLO						
UVLO	UVLO threshold	Wake-up V_{REG5} voltage	3.45	3.75	4.05	V
		Hysteresis V_{REG5} voltage	0.13	0.32	0.48	

6.6 Typical Characteristics

$V_{IN} = 12\text{ V}$, $T_A = 25^\circ\text{C}$ (unless otherwise noted).

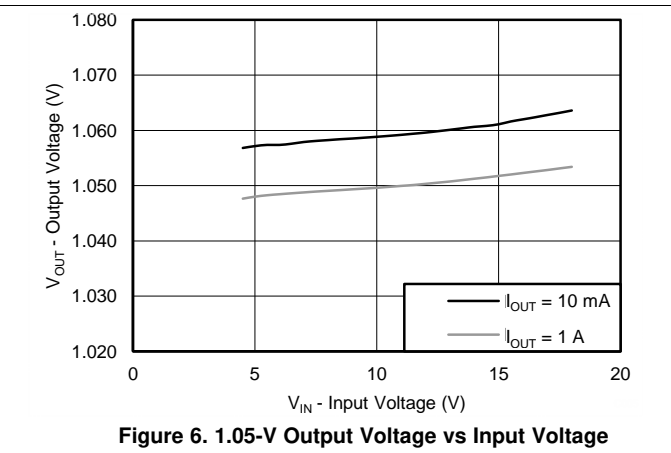
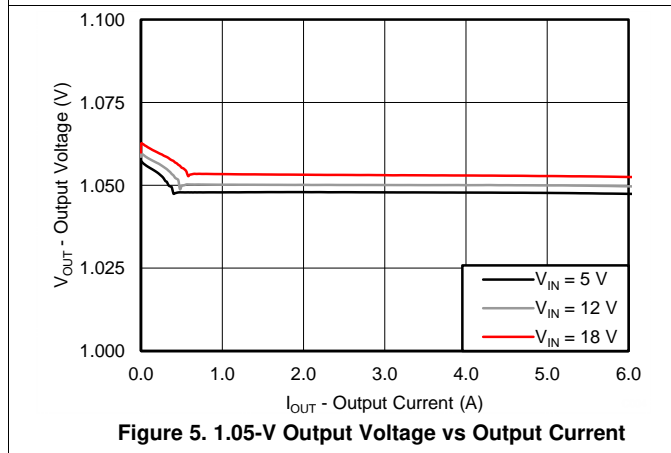
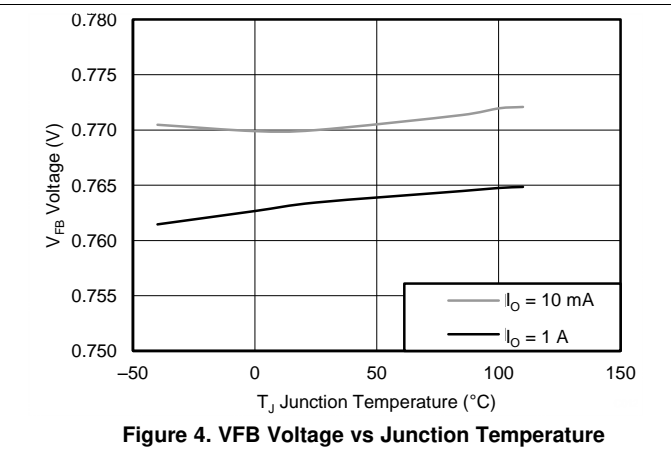
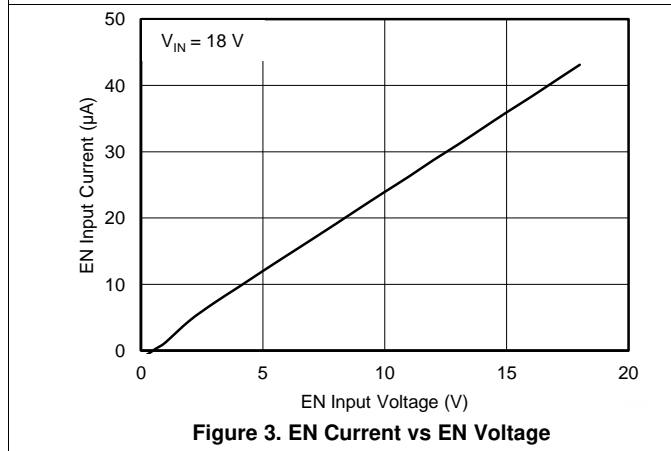
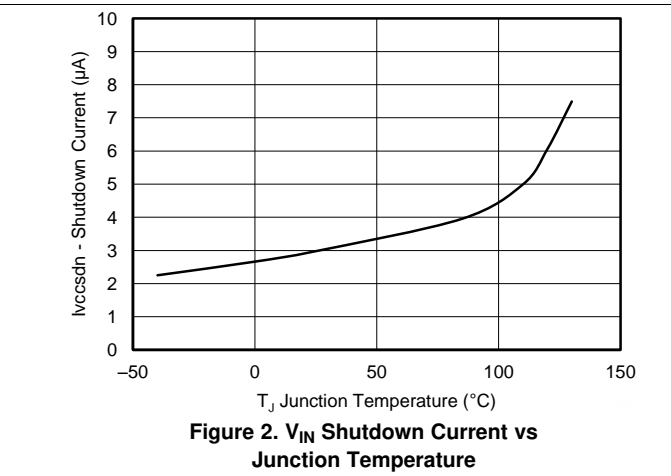
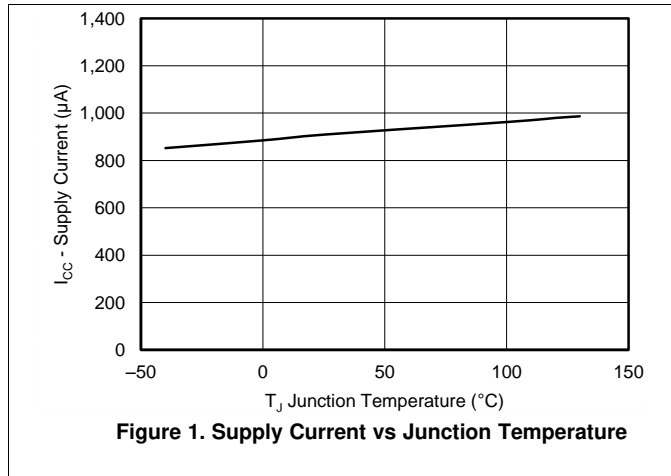

Typical Characteristics (continued)

$V_{IN} = 12\text{ V}$, $T_A = 25^\circ\text{C}$ (unless otherwise noted).

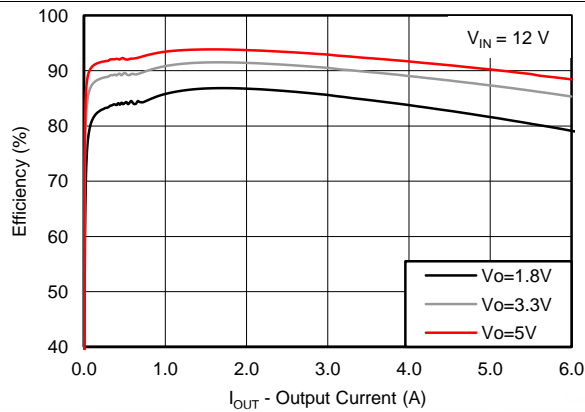

Figure 7. Efficiency vs Output Current

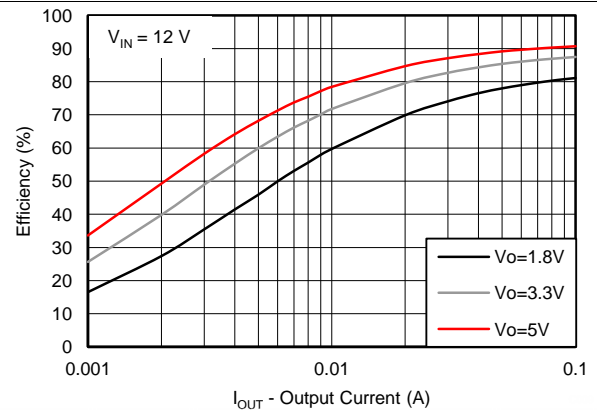

Figure 8. Light Load Efficiency vs Output Current

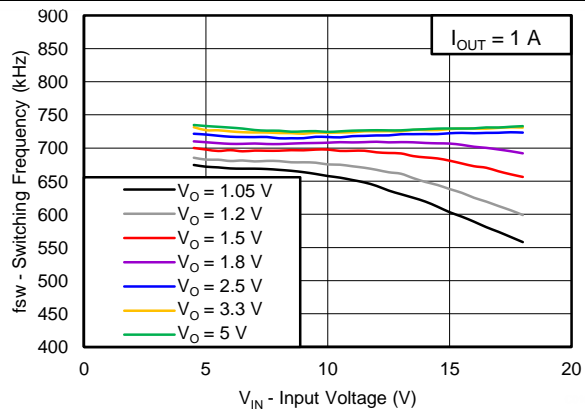

Figure 9. Switching Frequency vs Input Voltage

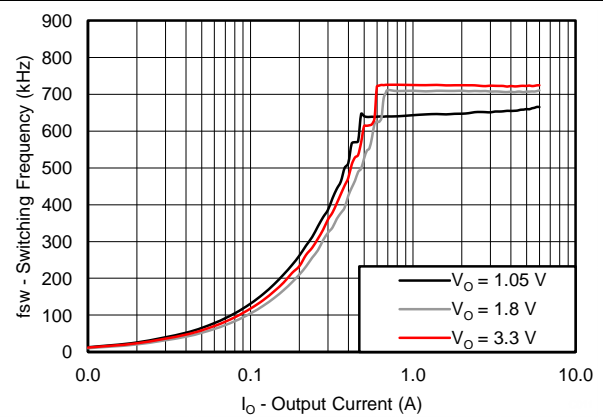

Figure 10. Switching Frequency vs Output Current

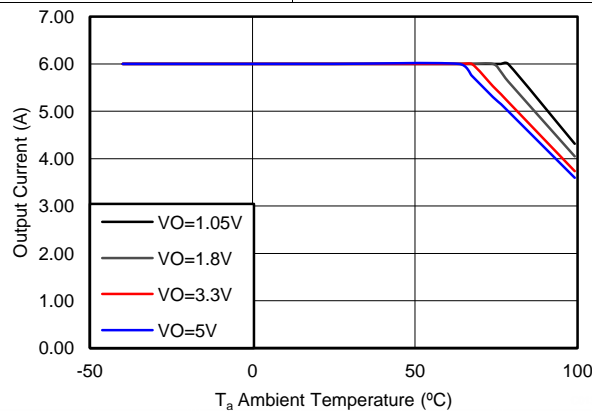

Figure 11. Output Current vs Ambient Temperature

7 Detailed Description

7.1 Overview

The TPS54628 is a 6-A Eco-Mode™ synchronous step-down (buck) converter with two integrated N-channel MOSFETs. It operates using D-CAP2™ mode control. The fast transient response of D-CAP2™ control reduces the output capacitance required to meet a specific level of performance. Proprietary internal circuitry allows the use of low-ESR output capacitors including ceramic and special polymer types.

7.2 Functional Block Diagram

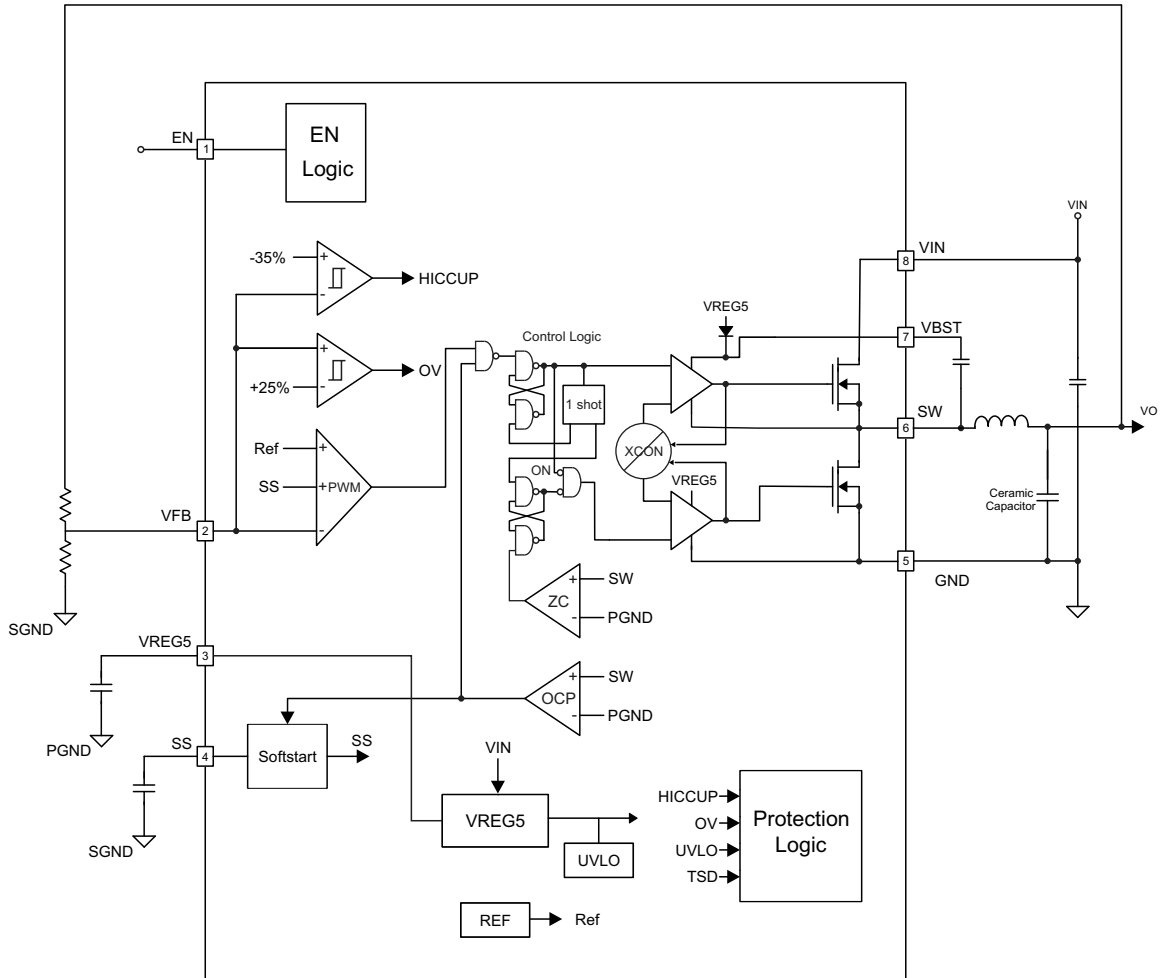

Copyright © 2016, Texas Instruments Incorporated

7.3 Feature Description

7.3.1 Auto-Skip Eco-Mode™ Control

The TPS54628 is designed with Auto-Skip Eco-Mode™ to increase light load efficiency. As the output current decreases from heavy load condition, the inductor current is also reduced and eventually comes to point that its rippled valley touches zero level, which is the boundary between continuous conduction and discontinuous conduction modes. The rectifying MOSFET is turned off when its zero inductor current is detected. As the load current further decreases the converter run into discontinuous conduction mode. The on time is kept almost the same as is was in the continuous conduction mode so that it takes longer time to discharge the output capacitor with smaller load current to the level of the reference voltage. The transition point to the light load operation $I_{OUT(LL)}$ current can be calculated in Equation 1.

$$I_{OUT(LL)} = \frac{1}{2 \cdot L \cdot f_{SW}} \cdot \frac{(V_{IN} - V_{OUT}) \cdot V_{OUT}}{V_{IN}} \quad (1)$$

7.3.2 Soft Start and Prebiased Soft Start

The soft-start function is adjustable. When the EN pin becomes high, 6- μ A current begins charging the capacitor which is connected from the SS pin to GND. Smooth control of the output voltage is maintained during start-up. The equation for the slow-start time is shown in Equation 2. VFB voltage is 0.765 V and SS pin source current is 6 μ A.

$$t_{ss}(\text{ms}) = \frac{C6(\text{nF}) \times V_{FB} \times 1.1}{I_{SS}(\mu\text{A})} = \frac{C6(\text{nF}) \times 0.765 \times 1.1}{6} \quad (2)$$

The TPS54628 contains a unique circuit to prevent current from being pulled from the output during start-up if the output is prebiased. When the soft-start commands a voltage higher than the prebias level (internal soft start becomes greater than feedback voltage V_{FB}), the controller slowly activates synchronous rectification by starting the first low-side FET gate driver pulses with a narrow on time. It then increments that on time on a cycle-by-cycle basis until it coincides with the time dictated by (1-D), where D is the duty cycle of the converter. This scheme prevents the initial sinking of the pre-bias output, and ensure that the out voltage (V_O) starts and ramps up smoothly into regulation and the control loop is given time to transition from prebiased start-up to normal mode operation.

7.3.3 Output Discharge Control

TPS54628 discharges the output when EN is low, or the controller is turned off by the UVLO protection. The internal low-side MOSFET is not turned on for the output discharge operation to avoid the possibility of causing negative voltage at the output.

7.3.4 Current Protection

The output overcurrent protection (OCP) is implemented using a cycle-by-cycle valley detect control circuit. The switch current is monitored by measuring the low-side FET switch voltage between the SW pin and GND. This voltage is proportional to the switch current. To improve accuracy, the voltage sensing is temperature compensated.

During the on time of the high-side FET switch, the switch current increases at a linear rate determined by V_{IN} , V_{OUT} , the on time and the output inductor value. During the on time of the low-side FET switch, this current decreases linearly. The average value of the switch current is the load current I_{OUT} . The TPS54628 constantly monitors the low-side FET switch voltage, which is proportional to the switch current, during the low-side on time. If the measured voltage is above the voltage proportional to the current limit, an internal counter is incremented per each SW cycle and the converter maintains the low-side switch on until the measured voltage is below the voltage corresponding to the current limit at which time the switching cycle is terminated and a new switching cycle begins. In subsequent switching cycles, the on time is set to a fixed value and the current is monitored in the same manner. If the overcurrent condition exists for 7 consecutive switching cycles, the internal OCL threshold is set to a lower level, reducing the available output current. When a switching cycle occurs where the switch current is not above the lower OCL threshold, the counter is reset and the OCL limit is returned to the higher value.

Feature Description (continued)

There are some important considerations for this type of overcurrent protection. The peak current is the average load current plus one half of the peak-to-peak inductor current. The valley current is the average load current minus one half of the peak-to-peak inductor current. Because the valley current is used to detect the overcurrent threshold, the load current is higher than the overcurrent threshold. Also, when the current is being limited, the output voltage tends to fall. When the VFB voltage becomes lower than 65% of the target voltage, the UVP comparator detects it. If the undervoltage condition persists for 250 μ s, the device shuts down and restarts in hiccup mode after 7 times the SS period. When the overcurrent condition is removed, the output voltage returns to the regulated value. This protection is non-latching.

7.3.5 Overvoltage Protection

TPS54628 detects overvoltage and undervoltage conditions by monitoring the feedback voltage (VFB). This function is enabled after approximately 1.7 times the soft-start time. When the feedback voltage becomes higher than 125% of the target voltage, the OVP comparator output goes high and both the high-side MOSFET driver and the low-side MOSFET driver turn off. This function is non-latch operation.

7.3.6 UVLO Protection

Undervoltage lockout protection (UVLO) monitors the voltage of the V_{REG5} pin. When the V_{REG5} voltage is lower than UVLO threshold voltage, the TPS54628 is shut off. This protection is non-latching.

7.3.7 Thermal Shutdown

TPS54628 monitors the temperature of itself. If the temperature exceeds the threshold value (typically 165°C), the device is shut off. This is non-latch protection.

7.4 Device Functional Modes

7.4.1 PWM Operation

The main control loop of the TPS54628 is an adaptive on-time pulse width modulation (PWM) controller that supports a proprietary D-CAP2™ mode control. D-CAP2™ mode control combines constant on-time control with an internal compensation circuit for pseudo-fixed frequency and low external component count configuration with both low-ESR and ceramic output capacitors. It is stable even with virtually no ripple at the output.

At the beginning of each cycle, the high-side MOSFET is turned on. This MOSFET is turned off after internal one-shot timer expires. This one shot is set by the converter input voltage, V_{IN} , and the output voltage, V_O , to maintain a pseudo-fixed frequency over the input voltage range, hence it is called adaptive on-time control. The one-shot timer is reset and the high-side MOSFET is turned on again when the feedback voltage falls below the reference voltage. An internal ramp is added to reference voltage to simulate output ripple, eliminating the ESR-induced output ripple from D-CAP2™ mode control.

7.4.2 PWM Frequency and Adaptive On-Time Control

TPS54628 uses an adaptive on-time control scheme and does not have a dedicated on board oscillator. The TPS54628 runs with a pseudo-constant frequency of 650 kHz by using the input voltage and output voltage to set the on-time one-shot timer. The on time is inversely proportional to the input voltage and proportional to the output voltage; therefore, when the duty ratio is V_{OUT}/V_{IN} , the frequency is constant.

8 Application and Implementation

NOTE

Information in the following applications sections is not part of the TI component specification, and TI does not warrant its accuracy or completeness. TI's customers are responsible for determining suitability of components for their purposes. Customers should validate and test their design implementation to confirm system functionality.

8.1 Application Information

The TPS54628 is designed to provide up to a 6-A output current from an input voltage source ranging from 4.5 V to 18 V. The output voltage is configurable from 0.76 V to 5.5 V. A simplified design procedure for a 1.05-V output is shown in [Figure 12](#).

8.2 Typical Application

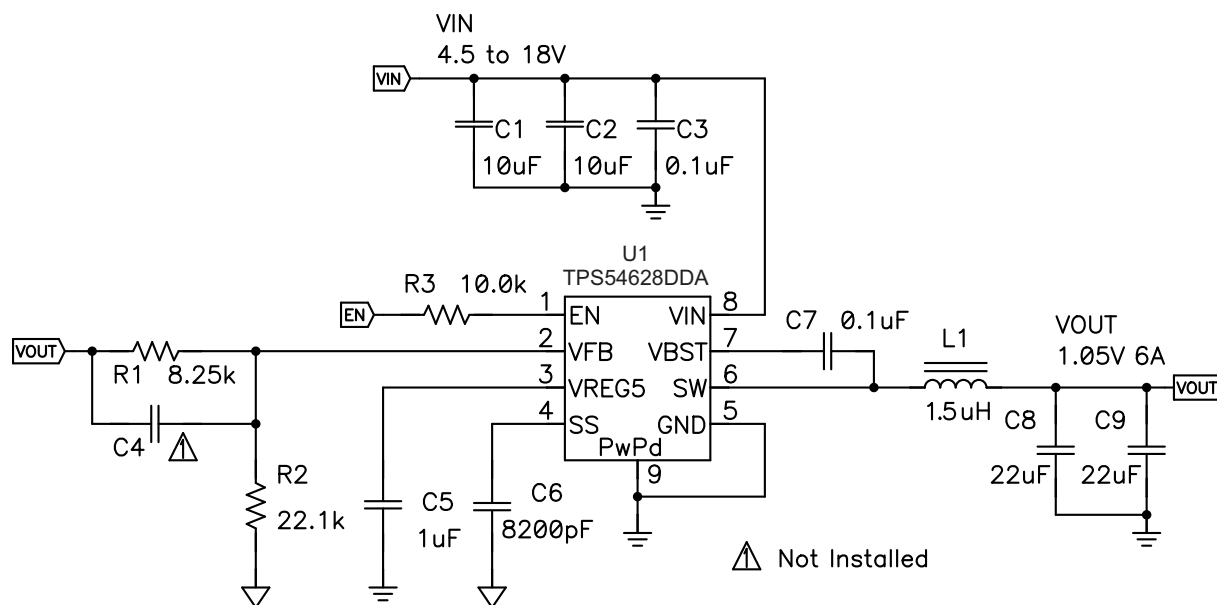

Copyright © 2016, Texas Instruments Incorporated

Figure 12. Simplified Application Schematic Example

8.2.1 Design Requirements

To begin the design process, the user must know the following application parameters:

- Input voltage range
- Output voltage
- Output current
- Output voltage ripple
- Input voltage ripple

8.2.2 Detailed Design Procedure

8.2.2.1 Output Voltage Resistors Selection

The output voltage is set with a resistor divider from the output node to the VFB pin. TI recommends using 1% tolerance or better divider resistors. Start by using [Equation 3](#) to calculate V_{OUT} .

$$V_{OUT} = 0.765 \times \left(1 + \frac{R1}{R2} \right) \quad (3)$$

Typical Application (continued)

To improve efficiency at light loads consider using larger value resistors, high resistance is more susceptible to noise, and the voltage errors from the VFB input current are more noticeable.

8.2.2.2 Output Filter Selection

The output filter used with the TPS54628 is an LC circuit. This LC filter has double pole at [Equation 4](#).

$$F_P = \frac{1}{2\pi\sqrt{L_{OUT} \times C_{OUT}}} \quad (4)$$

At low frequencies, the overall loop gain is set by the output setpoint resistor divider network and the internal gain of the TPS54628. The low frequency phase is 180 degrees. At the output filter pole frequency, the gain rolls off at a –40 dB per decade rate and the phase drops rapidly. D-CAP2 introduces a high frequency zero that reduces the gain roll off to –20 dB per decade and increases the phase to 90 degrees one decade above the zero frequency. The inductor and capacitor selected for the output filter must be selected so that the double pole of [Equation 4](#) is located below the high frequency zero, but close enough that the phase boost provided by the high frequency zero provides adequate phase margin for a stable circuit. To meet this requirement, use the values recommended in [Table 1](#).

Table 1. Recommended Component Values

OUTPUT VOLTAGE (V)	R1 (kΩ)	R2 (kΩ)	C4 (pF) ⁽¹⁾			L1 (μH)			C8 + C9 (μF)	
			MIN	TYP	MAX	MIN	TYP	MAX	MIN	MAX
1	6.81	22.1	5	150	220	1	1.5	4.7	22	68
1.05	8.25	22.1	5	150	220	1	1.5	4.7	22	68
1.2	12.7	22.1	5		100	1	1.5	4.7	22	68
1.5	21.5	22.1	5		68	1	1.5	4.7	22	68
1.8	30.1	22.1	5		22	1.2	1.5	4.7	22	68
2.5	49.9	22.1	5		22	1.5	2.2	4.7	22	68
3.3	73.2	22.1	2		22	1.8	2.2	4.7	22	68
5	124	22.1	2		22	2.2	3.3	4.7	22	68

(1) Optional

Because the DC gain is dependent on the output voltage, the required inductor value increases as the output voltage increases. Additional phase boost can be achieved by adding a feedforward capacitor (C4) in parallel with R1. The feedforward capacitor is most effective for output voltages at or above 1.8 V.

The inductor peak-to-peak ripple current, peak current and RMS current are calculated using [Equation 5](#), [Equation 6](#), and [Equation 7](#). The inductor saturation current rating must be greater than the calculated peak current and the RMS or heating current rating must be greater than the calculated RMS current. Use 700 kHz for f_{SW} .

Use 650 kHz for f_{SW} . Make sure the chosen inductor is rated for the peak current of [Equation 6](#) and the RMS current of [Equation 7](#).

$$I_{IPP} = \frac{V_{OUT}}{V_{IN(max)}} \times \frac{V_{IN(max)} - V_{OUT}}{L_O \times f_{SW}} \quad (5)$$

$$I_{Ipeak} = I_O + \frac{I_{IPP}}{2} \quad (6)$$

$$I_{Lo(RMS)} = \sqrt{I_O^2 + \frac{1}{12} I_{IPP}^2} \quad (7)$$

For this design example, the calculated peak current is 6.51 A and the calculated RMS current is 6.01 A. The inductor used is a TDK SPM6530-1R5M100 with a peak current rating of 11.6 A and an RMS current rating of 11 A.

The capacitor value and ESR determines the amount of output voltage ripple. The TPS54628 is intended for use with ceramic or other low-ESR capacitors. TI recommends the value range from 22 μF to 68 μF . Use [Equation 8](#) to determine the required RMS current rating for the output capacitor.

$$I_{\text{Co(RMS)}} = \frac{V_{\text{OUT}} \times (V_{\text{IN}} - V_{\text{OUT}})}{\sqrt{12} \times V_{\text{IN}} \times L_{\text{O}} \times f_{\text{SW}}} \quad (8)$$

For this design two TDK C3216X5R0J226M 22- μF output capacitors are used. The typical ESR is 2 m Ω each. The calculated RMS current is 0.284 A and each output capacitor is rated for 4 A.

8.2.2.3 Input Capacitor Selection

The TPS54628 requires an input decoupling capacitor and a bulk capacitor is required depending on the application. TI recommends using a ceramic capacitor over 10 μF for the decoupling capacitor. An additional 0.1- μF capacitor (C3) from pin 8 to ground is optional to provide additional high-frequency filtering. The capacitor voltage rating must be greater than the maximum input voltage.

8.2.2.4 Bootstrap Capacitor Selection

A 0.1- μF ceramic capacitor must be connected between the VBST to SW pin for proper operation. TI recommends using a ceramic capacitor.

8.2.2.5 VREG5 Capacitor Selection

A 1- μF ceramic capacitor must be connected between the VREG5 to GND pin for proper operation. TI recommends using a ceramic capacitor.

8.2.3 Application Curves

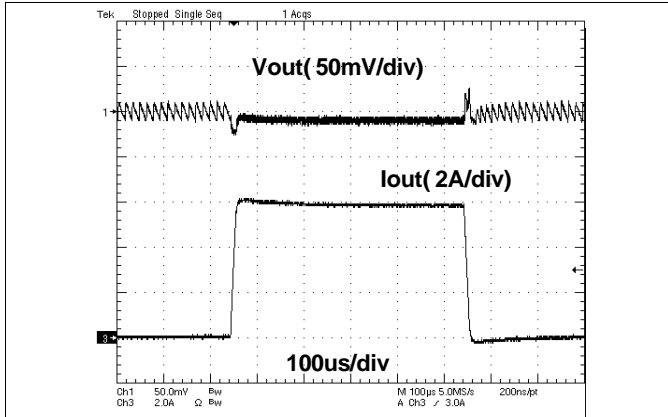

Figure 13. 1.05-V Load Transient Response

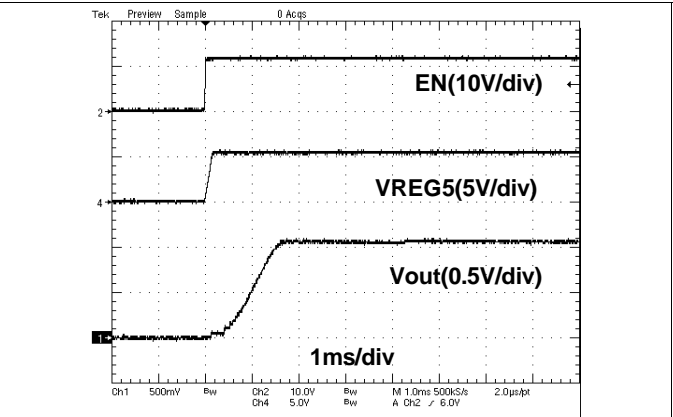
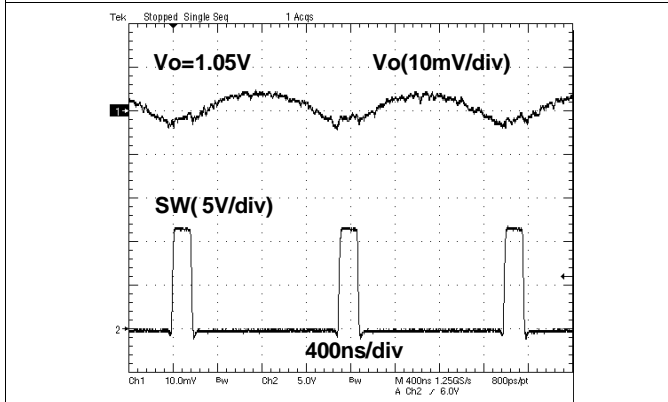
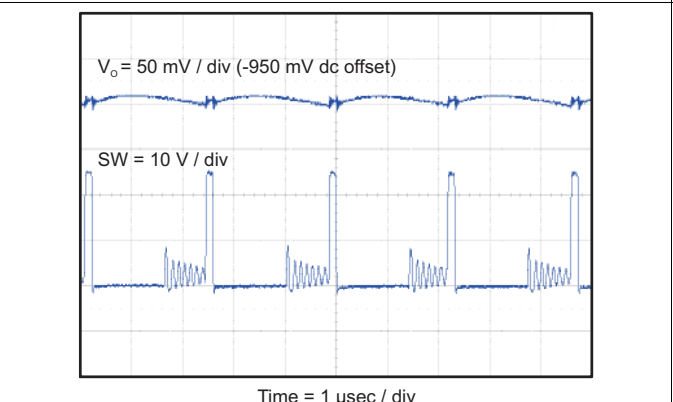

Figure 14. Start-Up Waveform



($I_O = 6\text{ A}$)

Figure 15. Voltage Ripple at Output



($I_O = 30\text{ mA}$)

Figure 16. DCM Voltage Ripple at Output

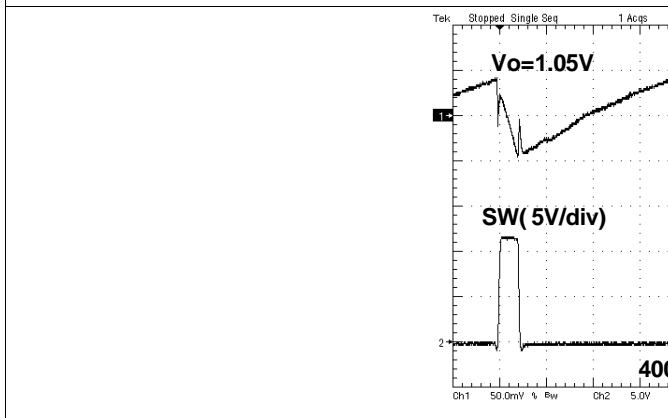

($I_O = 6\text{ A}$)

Figure 17. Voltage Ripple at Input

9 Power Supply Recommendations

The input voltage range is from 4.5 V to 18 V. The input power supply and the input capacitors must be placed as close to the device as possible to minimize the impedance of the power-supply line.

10 Layout

10.1 Layout Guidelines

The following lists the grounding and PCB circuit layout considerations:

1. The TPS54628 can supply large load currents up to 6 A, so heat dissipation may be a concern. The top-side area adjacent to the TPS54628 must be filled with ground as much as possible to dissipate heat.
2. The bottom-side area directly below the IC must a dedicated ground area. It must be directly connected to the thermal pad of the device using vias as shown. The ground area must be as large as practical. Additional internal layers can be dedicated as ground planes and connected to the vias as well.
3. Keep the input switching current loop as small as possible.
4. Keep the SW node as physically small and short as possible to minimize parasitic capacitance and inductance and to minimize radiated emissions. Kelvin connections must be brought from the output to the feedback pin of the device.
5. Keep analog and non-switching components away from switching components.
6. Make a single point connection from the signal ground to power ground.
7. Do not allow switching current to flow under the device.
8. Keep the pattern lines for VIN and PGND broad.
9. Exposed pad of device must be connected to PGND with solder.
10. VREG5 capacitor must be placed near the device, and connected PGND.
11. Output capacitor must be connected to a broad pattern of the PGND.
12. Voltage feedback loop must be as short as possible, and preferably with ground shield.
13. Lower resistor of the voltage divider which is connected to the VFB pin must be tied to SGND.
14. Providing sufficient via is preferable for VIN, SW and PGND connection.
15. PCB pattern for VIN, SW, and PGND must be as broad as possible.
16. VIN Capacitor must be placed as near as possible to the device.

10.2 Layout Example

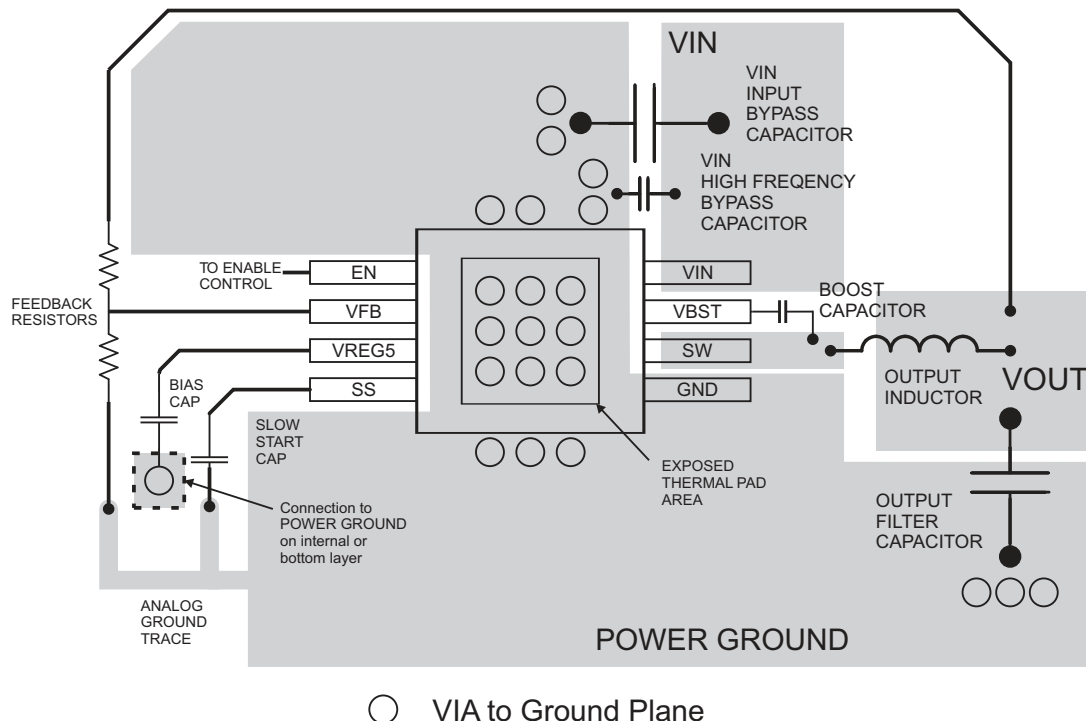

Figure 18. PCB Layout

10.3 Thermal Considerations

This 8-pin SO PowerPAD package incorporates an exposed thermal pad that is designed to be directly to an external heat sink. The thermal pad must be soldered directly to the printed-board (PCB). After soldering, the PCB can be used as a heat sink. In addition, through the use of thermal vias, the thermal pad can be attached directly to the appropriate copper plane shown in the electrical schematic for the device, or alternatively, can be attached to a special heat sink structure designed into the PCB. This design optimizes the heat transfer from the integrated circuit (IC).

For additional information on the exposed thermal pad and how to use the advantage of its heat dissipating abilities, see [PowerPAD™ Thermally Enhanced Package \(SLMA002\)](#) and [PowerPAD™ Made Easy \(SLMA004\)](#).

The exposed thermal pad dimensions for this package are shown in [Figure 19](#).

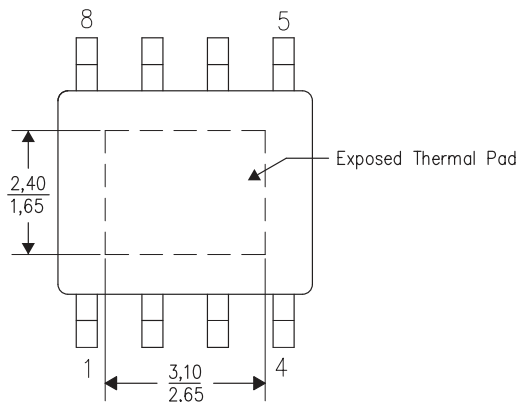

Figure 19. Thermal Pad Dimensions

11 Device and Documentation Support

11.1 Documentation Support

11.1.1 Related Documentation

For related documentation see the following:

- [PowerPAD™ Thermally Enhanced Package](#) (SLMA002)
- [PowerPAD™ Made Easy](#) (SLMA004)
- [TPS54628EVM-052, 6-A, Regulator Evaluation Module](#) (SLVU888)

11.2 Receiving Notification of Documentation Updates

To receive notification of documentation updates, navigate to the device product folder on ti.com. In the upper right corner, click on *Alert me* to register and receive a weekly digest of any product information that has changed. For change details, review the revision history included in any revised document.

11.3 Community Resources

The following links connect to TI community resources. Linked contents are provided "AS IS" by the respective contributors. They do not constitute TI specifications and do not necessarily reflect TI's views; see TI's [Terms of Use](#).

TI E2E™ Online Community *TI's Engineer-to-Engineer (E2E) Community*. Created to foster collaboration among engineers. At e2e.ti.com, you can ask questions, share knowledge, explore ideas and help solve problems with fellow engineers.

Design Support *TI's Design Support* Quickly find helpful E2E forums along with design support tools and contact information for technical support.

11.4 Trademarks

D-CAP2, Eco-Mode, E2E are trademarks of Texas Instruments.
Blu-Ray Disc is a trademark of Blu-ray Disc Association.
All other trademarks are the property of their respective owners.

11.5 Electrostatic Discharge Caution



These devices have limited built-in ESD protection. The leads should be shorted together or the device placed in conductive foam during storage or handling to prevent electrostatic damage to the MOS gates.

11.6 Glossary

[SLYZ022](#) — *TI Glossary*.

This glossary lists and explains terms, acronyms, and definitions.

12 Mechanical, Packaging, and Orderable Information

The following pages include mechanical, packaging, and orderable information. This information is the most current data available for the designated devices. This data is subject to change without notice and revision of this document. For browser-based versions of this data sheet, refer to the left-hand navigation.

PACKAGING INFORMATION

Orderable Device	Status (1)	Package Type	Package Drawing	Pins	Package Qty	Eco Plan (2)	Lead finish/ Ball material (6)	MSL Peak Temp (3)	Op Temp (°C)	Device Marking (4/5)	Samples
TPS54628DDA	ACTIVE	SO PowerPAD	DDA	8	75	RoHS & Green	NIPDAU SN	Level-2-260C-1 YEAR	-40 to 150	54628	Samples
TPS54628DDAR	ACTIVE	SO PowerPAD	DDA	8	2500	RoHS & Green	NIPDAU SN	Level-2-260C-1 YEAR	-40 to 150	54628	Samples

(1) The marketing status values are defined as follows:

ACTIVE: Product device recommended for new designs.

LIFEBUY: TI has announced that the device will be discontinued, and a lifetime-buy period is in effect.

NRND: Not recommended for new designs. Device is in production to support existing customers, but TI does not recommend using this part in a new design.

PREVIEW: Device has been announced but is not in production. Samples may or may not be available.

OBSOLETE: TI has discontinued the production of the device.

(2) **RoHS:** TI defines "RoHS" to mean semiconductor products that are compliant with the current EU RoHS requirements for all 10 RoHS substances, including the requirement that RoHS substance do not exceed 0.1% by weight in homogeneous materials. Where designed to be soldered at high temperatures, "RoHS" products are suitable for use in specified lead-free processes. TI may reference these types of products as "Pb-Free".

RoHS Exempt: TI defines "RoHS Exempt" to mean products that contain lead but are compliant with EU RoHS pursuant to a specific EU RoHS exemption.

Green: TI defines "Green" to mean the content of Chlorine (Cl) and Bromine (Br) based flame retardants meet JS709B low halogen requirements of <=1000ppm threshold. Antimony trioxide based flame retardants must also meet the <=1000ppm threshold requirement.

(3) MSL, Peak Temp. - The Moisture Sensitivity Level rating according to the JEDEC industry standard classifications, and peak solder temperature.

(4) There may be additional marking, which relates to the logo, the lot trace code information, or the environmental category on the device.

(5) Multiple Device Markings will be inside parentheses. Only one Device Marking contained in parentheses and separated by a "~" will appear on a device. If a line is indented then it is a continuation of the previous line and the two combined represent the entire Device Marking for that device.

(6) Lead finish/Ball material - Orderable Devices may have multiple material finish options. Finish options are separated by a vertical ruled line. Lead finish/Ball material values may wrap to two lines if the finish value exceeds the maximum column width.

Important Information and Disclaimer:The information provided on this page represents TI's knowledge and belief as of the date that it is provided. TI bases its knowledge and belief on information provided by third parties, and makes no representation or warranty as to the accuracy of such information. Efforts are underway to better integrate information from third parties. TI has taken and continues to take reasonable steps to provide representative and accurate information but may not have conducted destructive testing or chemical analysis on incoming materials and chemicals. TI and TI suppliers consider certain information to be proprietary, and thus CAS numbers and other limited information may not be available for release.

In no event shall TI's liability arising out of such information exceed the total purchase price of the TI part(s) at issue in this document sold by TI to Customer on an annual basis.

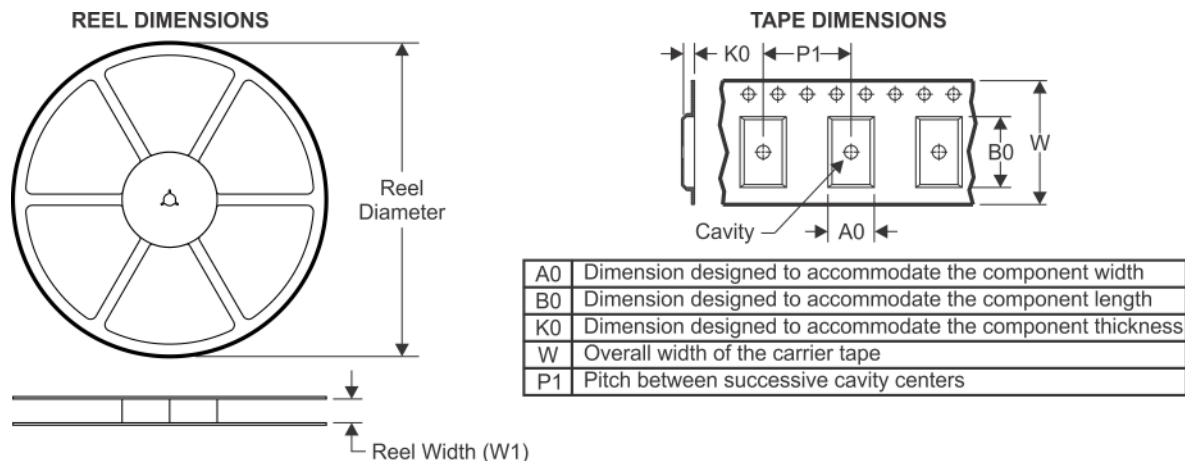
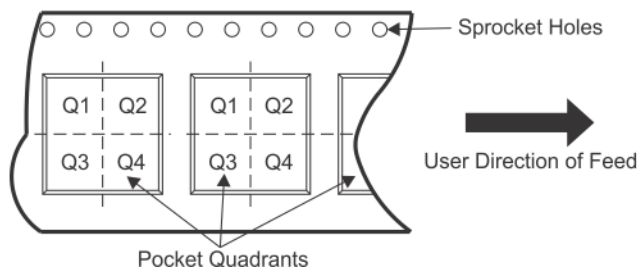
TAPE AND REEL INFORMATION

QUADRANT ASSIGNMENTS FOR PIN 1 ORIENTATION IN TAPE

*All dimensions are nominal

Device	Package Type	Package Drawing	Pins	SPQ	Reel Diameter (mm)	Reel Width W1 (mm)	A0 (mm)	B0 (mm)	K0 (mm)	P1 (mm)	W (mm)	Pin1 Quadrant
TPS54628DDAR	SO Power PAD	DDA	8	2500	330.0	12.8	6.4	5.2	2.1	8.0	12.0	Q1

TAPE AND REEL BOX DIMENSIONS



*All dimensions are nominal

Device	Package Type	Package Drawing	Pins	SPQ	Length (mm)	Width (mm)	Height (mm)
TPS54628DDAR	SO PowerPAD	DDA	8	2500	366.0	364.0	50.0

TUBE

*All dimensions are nominal

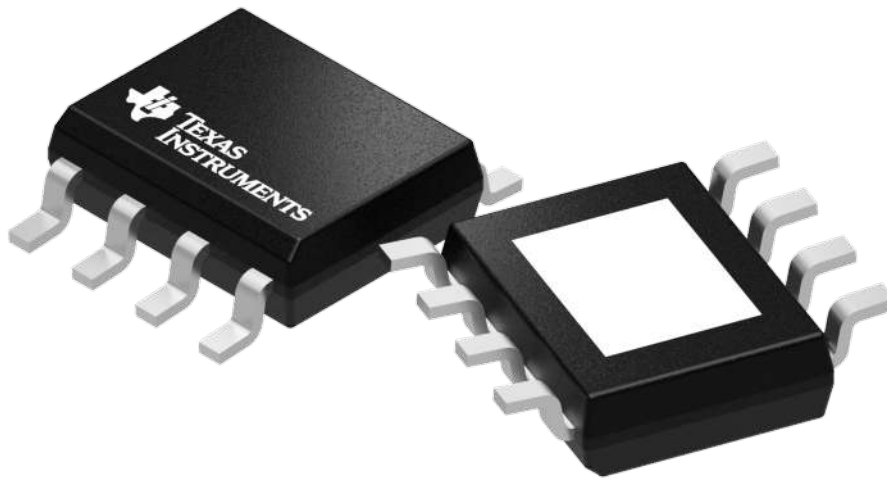
Device	Package Name	Package Type	Pins	SPQ	L (mm)	W (mm)	T (μm)	B (mm)
TPS54628DDA	DDA	HSOIC	8	75	517	7.87	635	4.25
TPS54628DDA	DDA	HSOIC	8	75	508	7.77	2540	NA



Images above are just a representation of the package family, actual package may vary.
Refer to the product data sheet for package details.

DDA (R-PDSO-G8)

PowerPAD™ PLASTIC SMALL-OUTLINE

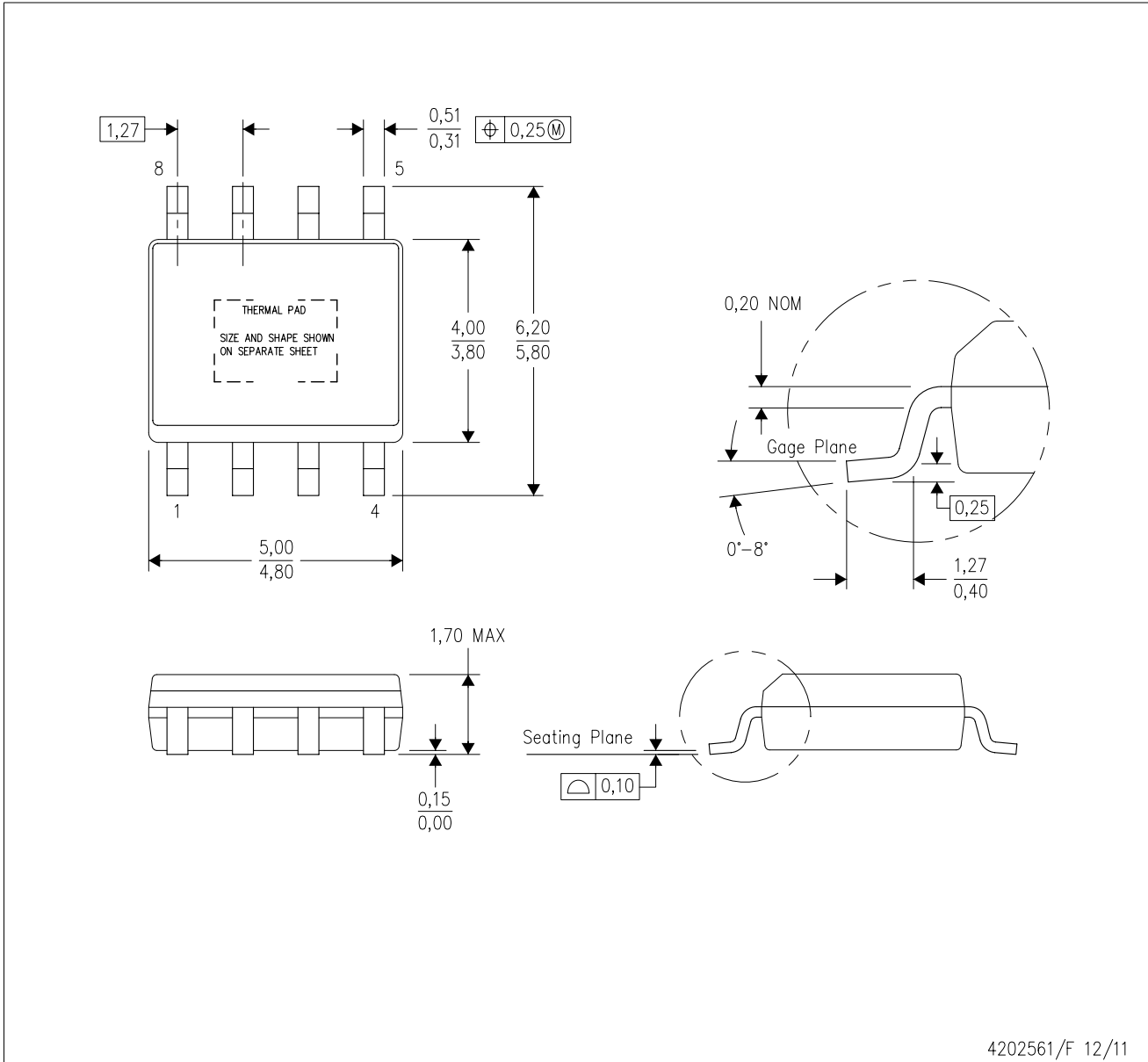

4202561/F 12/11

- NOTES:
- A. All linear dimensions are in millimeters. Dimensioning and tolerancing per ASME Y14.5-1994.
 - B. This drawing is subject to change without notice.
 - C. Body dimensions do not include mold flash or protrusion not to exceed 0,15.
 - D. This package is designed to be soldered to a thermal pad on the board. Refer to Technical Brief, PowerPad Thermally Enhanced Package, Texas Instruments Literature No. SLMA002 for information regarding recommended board layout. This document is available at www.ti.com <<http://www.ti.com>>.
 - E. See the additional figure in the Product Data Sheet for details regarding the exposed thermal pad features and dimensions.
 - F. This package complies to JEDEC MS-012 variation BA

PowerPAD is a trademark of Texas Instruments.

DDA (R-PDSO-G8)

PowerPAD™ PLASTIC SMALL OUTLINE

THERMAL INFORMATION

This PowerPAD™ package incorporates an exposed thermal pad that is designed to be attached to a printed circuit board (PCB). The thermal pad must be soldered directly to the PCB. After soldering, the PCB can be used as a heatsink. In addition, through the use of thermal vias, the thermal pad can be attached directly to the appropriate copper plane shown in the electrical schematic for the device, or alternatively, can be attached to a special heatsink structure designed into the PCB. This design optimizes the heat transfer from the integrated circuit (IC).

For additional information on the PowerPAD package and how to take advantage of its heat dissipating abilities, refer to Technical Brief, PowerPAD Thermally Enhanced Package, Texas Instruments Literature No. SLMA002 and Application Brief, PowerPAD Made Easy, Texas Instruments Literature No. SLMA004. Both documents are available at www.ti.com.

The exposed thermal pad dimensions for this package are shown in the following illustration.

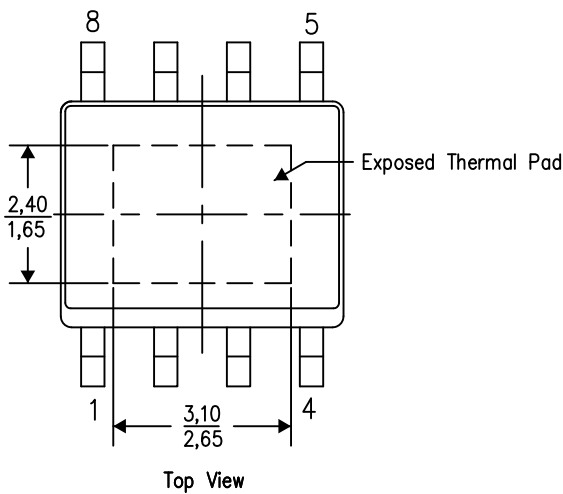

Exposed Thermal Pad Dimensions

4206322-6/L 05/12

NOTE: A. All linear dimensions are in millimeters

PowerPAD is a trademark of Texas Instruments

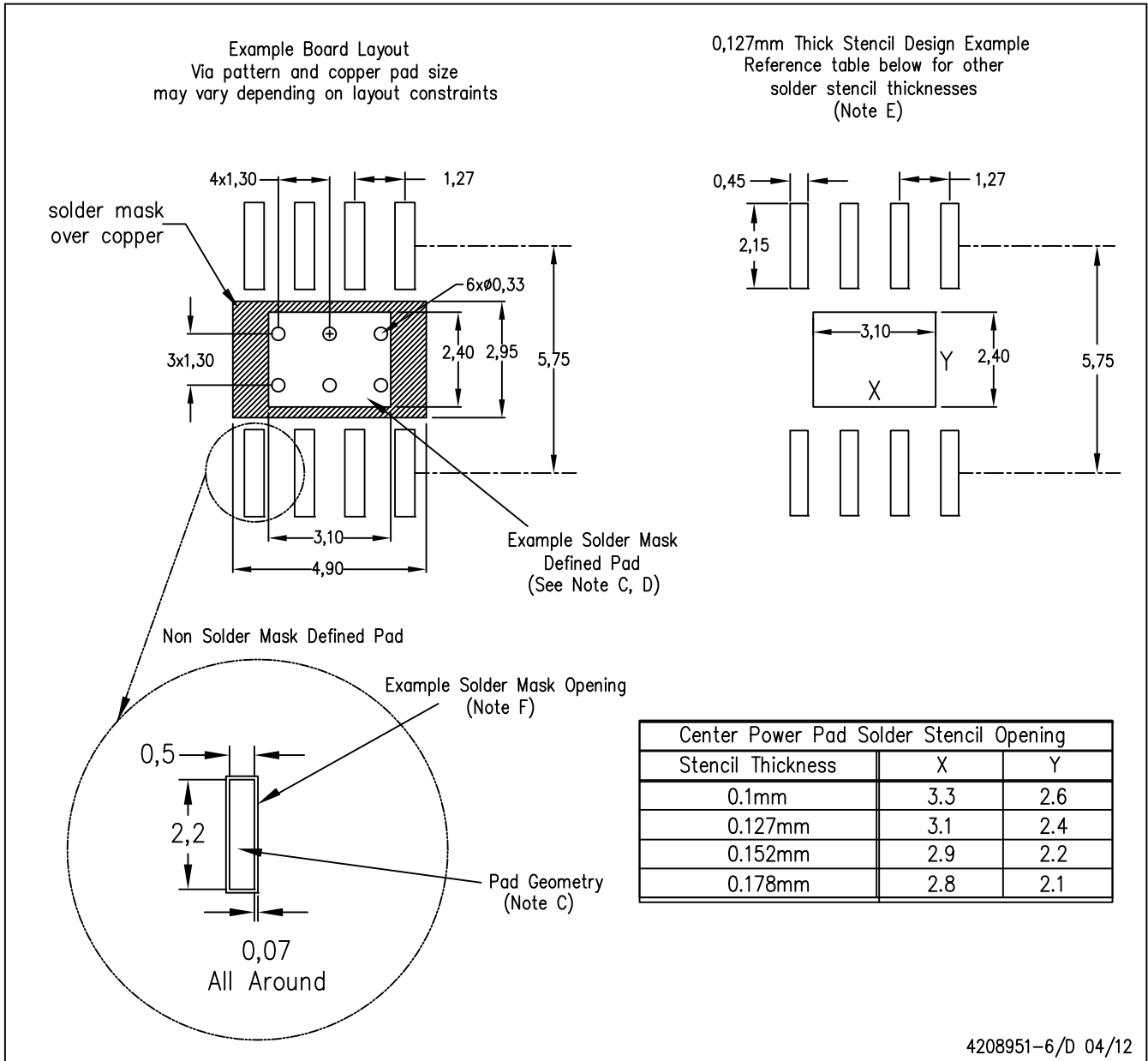

- NOTES:
- A. All linear dimensions are in millimeters.
 - B. This drawing is subject to change without notice.
 - C. Publication IPC-7351 is recommended for alternate designs.
 - D. This package is designed to be soldered to a thermal pad on the board. Refer to Technical Brief, PowerPad Thermally Enhanced Package, Texas Instruments Literature No. SLMA002, SLMA004, and also the Product Data Sheets for specific thermal information, via requirements, and recommended board layout. These documents are available at www.ti.com <<http://www.ti.com>>. Publication IPC-7351 is recommended for alternate designs.
 - E. Laser cutting apertures with trapezoidal walls and also rounding corners will offer better paste release. Customers should contact their board assembly site for stencil design recommendations. Example stencil design based on a 50% volumetric metal load solder paste. Refer to IPC-7525 for other stencil recommendations.
 - F. Customers should contact their board fabrication site for solder mask tolerances between and around signal pads.

PowerPAD is a trademark of Texas Instruments.

IMPORTANT NOTICE AND DISCLAIMER

TI PROVIDES TECHNICAL AND RELIABILITY DATA (INCLUDING DATA SHEETS), DESIGN RESOURCES (INCLUDING REFERENCE DESIGNS), APPLICATION OR OTHER DESIGN ADVICE, WEB TOOLS, SAFETY INFORMATION, AND OTHER RESOURCES "AS IS" AND WITH ALL FAULTS, AND DISCLAIMS ALL WARRANTIES, EXPRESS AND IMPLIED, INCLUDING WITHOUT LIMITATION ANY IMPLIED WARRANTIES OF MERCHANTABILITY, FITNESS FOR A PARTICULAR PURPOSE OR NON-INFRINGEMENT OF THIRD PARTY INTELLECTUAL PROPERTY RIGHTS.

These resources are intended for skilled developers designing with TI products. You are solely responsible for (1) selecting the appropriate TI products for your application, (2) designing, validating and testing your application, and (3) ensuring your application meets applicable standards, and any other safety, security, regulatory or other requirements.

These resources are subject to change without notice. TI grants you permission to use these resources only for development of an application that uses the TI products described in the resource. Other reproduction and display of these resources is prohibited. No license is granted to any other TI intellectual property right or to any third party intellectual property right. TI disclaims responsibility for, and you will fully indemnify TI and its representatives against, any claims, damages, costs, losses, and liabilities arising out of your use of these resources.

TI's products are provided subject to [TI's Terms of Sale](#) or other applicable terms available either on ti.com or provided in conjunction with such TI products. TI's provision of these resources does not expand or otherwise alter TI's applicable warranties or warranty disclaimers for TI products.

TI objects to and rejects any additional or different terms you may have proposed.

Mailing Address: Texas Instruments, Post Office Box 655303, Dallas, Texas 75265
Copyright © 2022, Texas Instruments Incorporated