

Slotted Optical Switch

OPB610, OPB620, OPB621

Obsolete (OPB611)



Features:

- Non-contact switching
- Printed circuit board mounting
- Enhanced signal to noise ratio
- PIN photodiode sensor for high speed (OPB621)
- Lead centers: 0.275: (OPB61_) / 0.320" (OPB62_)

Description:

The **OPB610** and **OPB620** slotted optical switches consist of an infrared emitting diode and an NPN silicon phototransistor with an enhanced low current roll-off to improve contrast ratio and immunity to background irradiance.

The **OPB621** slotted optical switch consists of an infrared emitting diode and a PIN photodiode with a polysulfone housing that is opaque to visible light, but transmissive to infrared. The low t_r/t_f of the PIN photodiode is ideal for high-speed operation. The sensitivity to ambient radiation is minimized.

Custom electrical, wire and cabling and connectors are available. Contact your local representative or OPTEK for more information.

Applications:

- Non-contact reflective object sensor
- Assembly line automation
- Machine automation
- Machine safety
- End of travel sensor
- Door sensor

Ordering Information				
Part Number	LED Peak Wavelength	Sensor	Slot Width / Depth	Aperture Emitter / Sensor
OPB610	890 nm	Rbe Transistor	0.150" / 0.240"	0.06" / 0.06"
OPB611 Obsolete		Diode		
OPB620	890 nm	Rbe Transistor	0.190" / 0.285"	0.100" / 0.320"
OPB621		Diode		

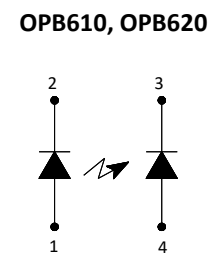
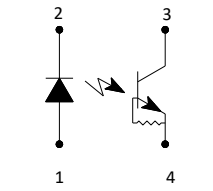
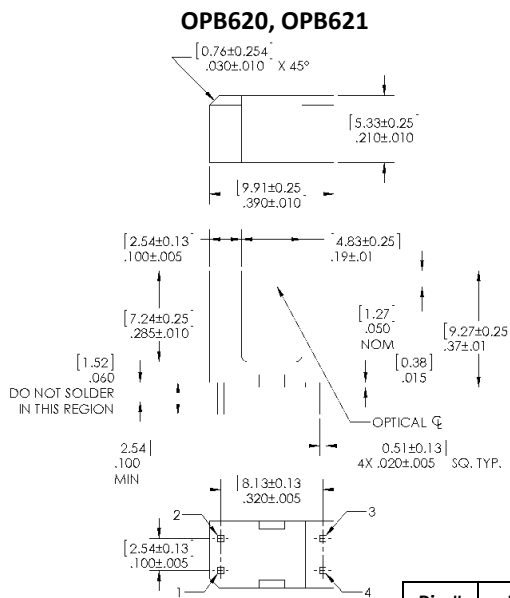
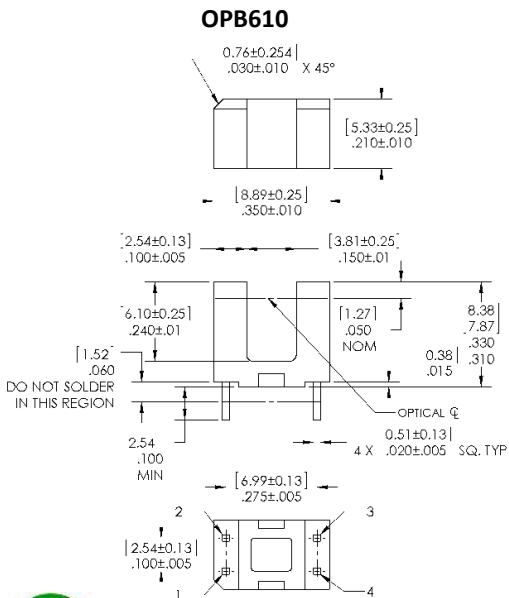

RoHS

DIMENSIONS ARE IN: [MILLIMETERS] INCHES

Pin #	LED	Pin #	Transistor / Diode
1	Anode	4	Emitter / Anode
2	Cathode	3	Collector / Cathode

General Note

TT Electronics reserves the right to make changes in product specification without notice or liability. All information is subject to TT Electronics' own data and is considered accurate at time of going to print.

TT Electronics | OPTEK Technology
2900 E. Plano Pkwy, Plano, TX 75074 | Ph: +1 972 323 2200
www.ttelectronics.com | sensors@ttelectronics.com

Slotted Optical Switch

OPB610, OPB620, OPB621

Obsolete (OPB611)



Electrical Specifications

Absolute Maximum Ratings ($T_A = 25^\circ\text{C}$ unless otherwise noted)

Storage and Operating Temperature Range	-40° C to +100° C
Lead Soldering Temperature [1/16 inch (1.6 mm) from the case for 5 sec. with soldering iron] ⁽¹⁾	260° C

Input Diode

Forward DC Current	50 mA
Peak Forward Current (1 μs pulse width, 300 pps)	3 A
Reverse DC Voltage	3 V
Power Dissipation ⁽²⁾	100 mW

Output Photodiode (OPB621)

Reverse Breakdown Voltage	60 V
Power Dissipation	100 mW

Output Phototransistor (OPB610, OPB620)

Collector-Emitter Voltage	24 V
Emitter-Reverse Current	10 mA
Collector DC Current	30 mA
Power Dissipation ⁽³⁾	200 mW

General Note

TT Electronics reserves the right to make changes in product specification without notice or liability. All information is subject to TT Electronics' own data and is considered accurate at time of going to print.

TT Electronics | OPTEK Technology
2900 E. Plano Pkwy, Plano, TX 75074 | Ph: +1 972 323 2200
www.ttelectronics.com | sensors@ttelectronics.com

Slotted Optical Switch

OPB610, OPB620, OPB621

Obsolete (OPB611)



Electrical Specifications

Electrical Characteristics ($T_A = 25^\circ\text{C}$ unless otherwise noted)

SYMBOL	PARAMETER	MIN	TYP	MAX	UNITS	TEST CONDITIONS
--------	-----------	-----	-----	-----	-------	-----------------

Input Diode (See OP240 for additional information)

V_F	Forward Voltage OPB610, OPB620 OPB621	-	-	1.6	V	$I_F = 10\text{ mA}$
		1.15	-	1.45	V	$I_F = 10\text{ mA}$
I_R	Reverse Current	-	-	100	μA	$V_R = 3\text{ V}$

Output Phototransistor (OPB610, OPB620) (See OP505 for additional information)

$V_{(BR)CEO}$	Collector-Emitter Breakdown Voltage	24	-	-	V	$I_C = 100\ \mu\text{A}$
BV_{ECO}	Emitter-Collector Breakdown Voltage	0.4	-	-	V	$I_{CE} = 100\ \mu\text{A}$
I_{CEO}	Collector-Emitter Dark Current	-	-	100	nA	$V_{CE} = 5\text{ V}$

Output Photodiode (OPB621) (See OP999 for additional information)

I_D	Dark Current	-	-	65	nA	$V_R = 30\text{ V}, E_E = 0\text{ mW}$
$V_{(BR)R}$	Reverse Breakdown Voltage	60	-	-	V	$I_R = 100\ \mu\text{A}, E_E = 0\text{ mW}$
V_F	Forward Voltage	-	-	1.0	V	$I_F = 1\text{ mA}, E_E = 0\text{ mW}$

Combined

V_{SAT}	Collector-Emitter Saturation Voltage OPB610, OPB620	-	-	0.4	V	$I_F = 5\text{ mA}, I_C = 100\ \mu\text{A}$
$I_{C(ON)}$	On-State Collector/Diode Current OPB610, OPB620 OPB621	1	-	-	mA	$I_F = 5\text{ mA}, V_{CE} = 5\text{ V}$ (gap unblocked) $V_R = 5\text{ V}, I_F = 20\text{ mA}$ (gap unblocked)
		9	-	90	μA	

Notes:

- (1) RMA flux is recommended. Duration can be extended to 10 seconds maximum when flow soldering. A maximum of 20 grams force may be applied to leads when soldering.
- (2) Derate linearly 1.33 mW/ $^\circ\text{C}$ above 25 $^\circ\text{C}$.
- (3) Derate linearly 2.0 mW/ $^\circ\text{C}$ above 25 $^\circ\text{C}$.
- (4) Plastic body is soluble in chlorinated hydrocarbons and keytones. It is recommended that a trial exposure to flux & cleaning chemicals is performed to ensure sensor is not damaged.

General Note

TT Electronics reserves the right to make changes in product specification without notice or liability. All information is subject to TT Electronics' own data and is considered accurate at time of going to print.

TT Electronics | OPTEK Technology
2900 E. Plano Pkwy, Plano, TX 75074 | Ph: +1 972 323 2200
www.ttelectronics.com | sensors@ttelectronics.com

Slotted Optical Switch

OPB610, OPB620, OPB621

Obsolete (OPB611)



Performance

OPB610 - Flag Next to Emitter

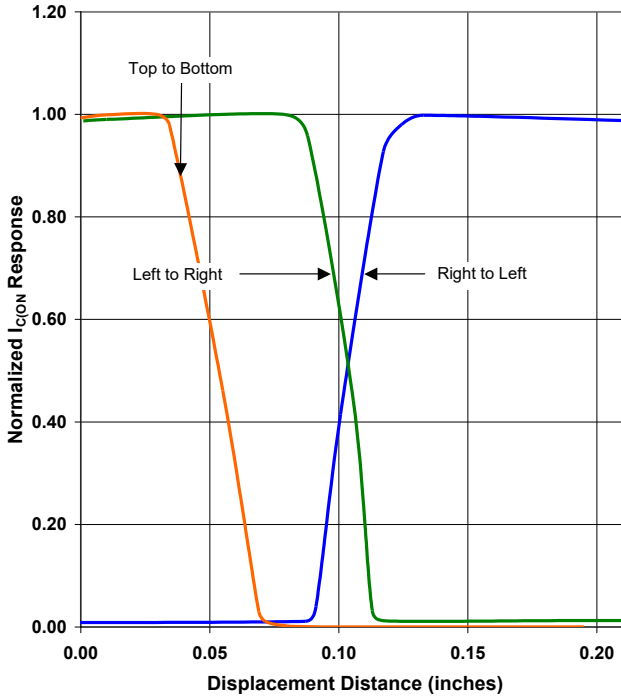

OPB610 - Flag Next to Sensor

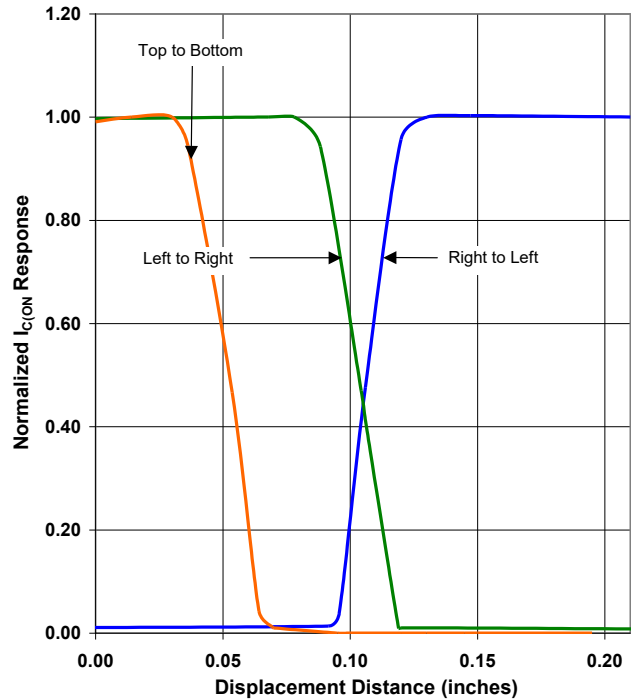

OPB610 - Flag in Middle of Slot

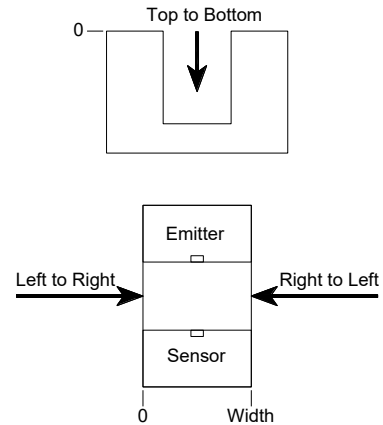
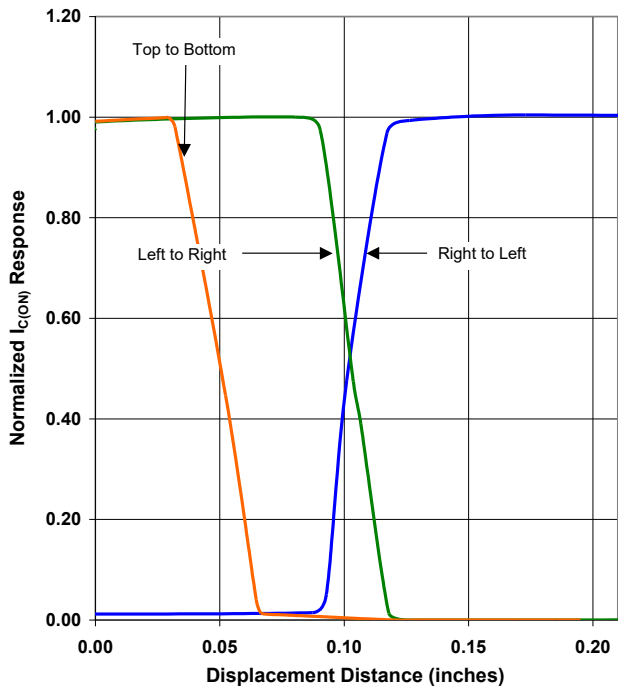

General Note

TT Electronics reserves the right to make changes in product specification without notice or liability. All information is subject to TT Electronics' own data and is considered accurate at time of going to print.

TT Electronics | OPTEK Technology
 2900 E. Plano Pkwy, Plano, TX 75074 | Ph: +1 972 323 2200
www.ttelectronics.com | sensors@ttelectronics.com

Slotted Optical Switch

OPB610, OPB620, OPB621

Obsolete (OPB611)



Performance

OPB620 - Flag Next to Emitter

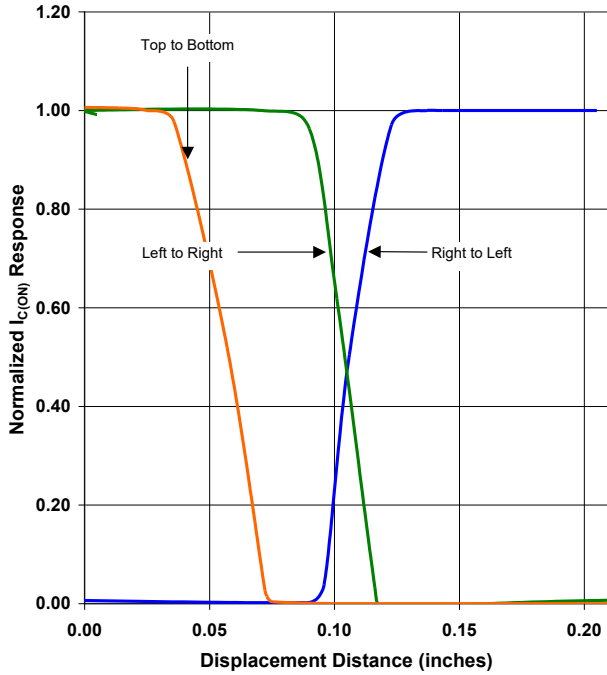

OPB620 - Flag Next to Sensor

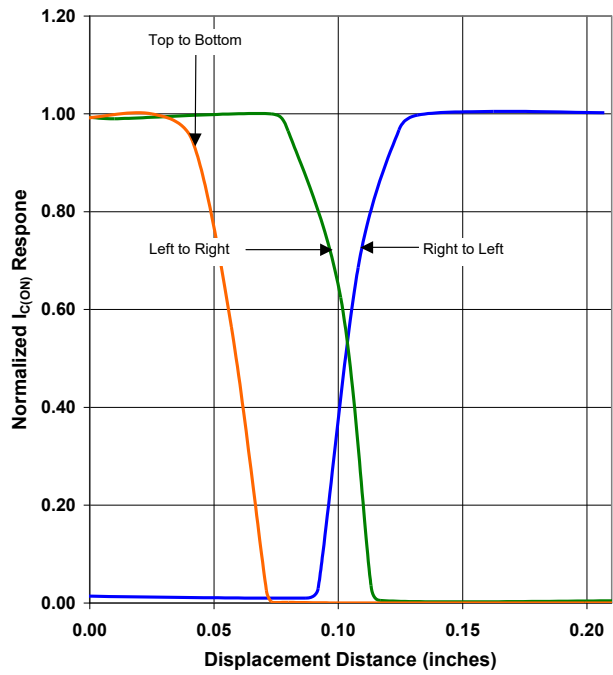

OPB620 - Flag in Middle of Slot

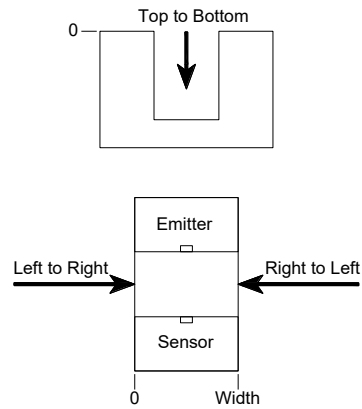
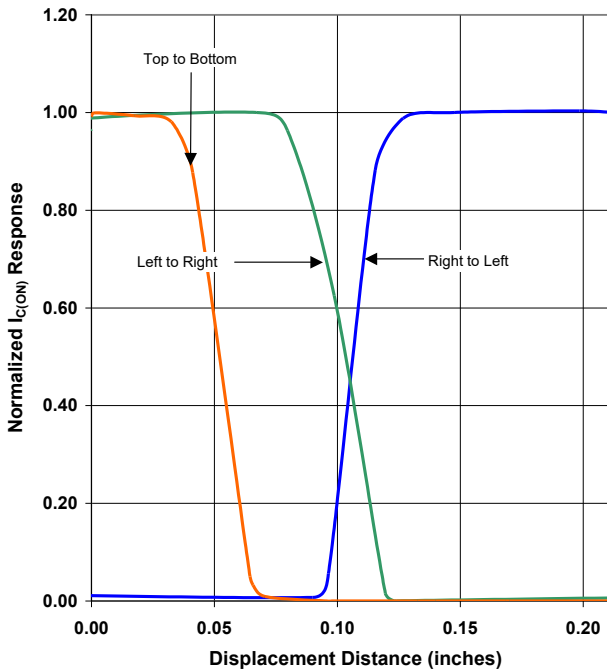

General Note
 TT Electronics reserves the right to make changes in product specification without notice or liability. All information is subject to TT Electronics' own data and is considered accurate at time of going to print.

TT Electronics | OPTEK Technology
 2900 E. Plano Pkwy, Plano, TX 75074 | Ph: +1 972 323 2200
www.ttelectronics.com | sensors@ttelectronics.com