

ISL8014AEVAL2Z

4A Low Quiescent Current 1MHz High Efficiency Synchronous Buck Regulator
 Demonstration Board 3-Phase Module with HIP2103/4 Drivers

AN1366
 Rev 3.00
 December 16, 2009

Description

The ISL8014AEVAL2Z kit is intended for use by individuals with requirements for Point-of-Load applications sourcing from 2.7V to 5.5V. The ISL8014AEVAL2Z evaluation board demonstrates the performance of the ISL8014A low quiescent current mode converter.

The ISL8014A is offered in a 4mmx4mm 16 Ld QFN package with 1mm maximum height. The ISL8014A is pin-to-pin compatible to the ISL8013A. The complete converter occupies less than 0.4in² area.

Key Features

- High Efficiency Synchronous Buck Regulator with up to 95% Efficiency
- Power-Good (PG) Output with 1ms Delay
- 2.7V to 5.5V Supply Voltage
- 3% Output Accuracy Over-Temperature/Load/Line
- 4A Guaranteed Output Current
- Start-up with Pre-biased Output
- Internal Digital Soft-Start - 1ms
- Soft-Stop Output Discharge During Disabled
- 35µA Quiescent Supply Current in PFM Mode
- Selectable Forced PWM Mode and PFM Mode
- External Synchronization up to 4MHz
- Less than 1µA Logic Controlled Shutdown Current
- 100% Maximum Duty Cycle for Lowest Dropout
- Internal Current Mode Compensation
- Peak Current Limiting and Hiccup Mode Short Circuit Protection
- Over-Temperature Protection

Recommended Equipment

The following materials are recommended to perform testing:

- 0V to 10V Power Supply with at least 5A Source Current Capability or 5V Battery
- Electronic Loads Capable of Sinking Current Up to 5A
- Digital Multimeters (DMMs)
- 100MHz Quad-trace Oscilloscope
- Signal Generator

Quick Setup Guide

1. Ensure that the circuit is correctly connected to the supply and loads prior to applying any power.
2. Connect the bias supply to VIN. Plus terminal to P4 (VIN) and negative return to P5 (GND).
3. Verify that position is ON for SW1.
4. Turn on the power supply.
5. Verify the output voltage is 1.8V for V_{OUT}

Evaluating the Other Output Voltage

The ISL8014AEVAL2Z kit output is preset to 1.8V; however, output voltages can be adjusted from 0.8V to 3.3V using Equations 1 and 2:

$$V_{OUT} = 0.8 \left(1 + \frac{R_1}{R_2} \right) \quad (\text{EQ. 1})$$

Let's set R₁ = 124kΩ

$$R_2 = \frac{(R_1)}{\left(\frac{V_{OUT}}{0.8} \right) - 1} \quad (\text{EQ. 2})$$

Note: If desired output is 0.8V, then short R₁ and open R₂.

Mode Control

The ISL8014A has a SKIP pin that controls the operation mode. When the SKIP pin is driven to low or shorted to ground, the regulator operates in a PFM mode. Set SKIP pin high forced PWM mode. The controller remains in the fixed PWM frequency at light load instead of entering the skip mode. In an application where situations require the ISL8014A regulator to sink more than 2A valley inductor current, it is recommended to operate in PFM to avoid any possible over stress.

TABLE 1. SWITCH 1 SETTINGS

SW 1	ENABLE	ON/ OFF CONTROL
1	OFF	Disable V _{OUT}
3	ON	Enable V _{OUT}
SW 2	SKIP	FUNCTION
1	PWM	Fixed PWM frequency at light load
3	PFM	Force continuous mode

ISL8014AEVAL2Z Schematic

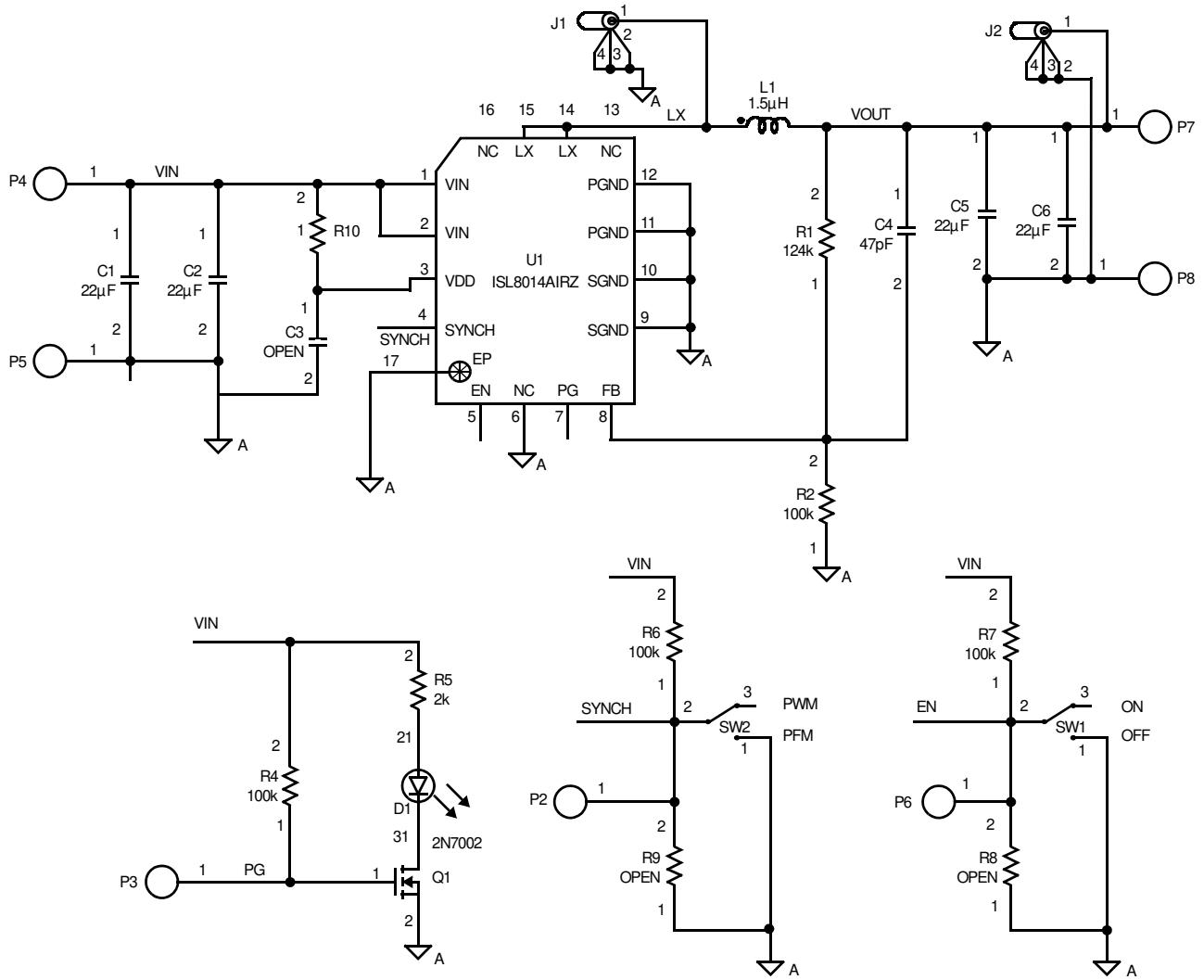

NOTE: Pins 13 and 16 are no connect pins which can tie to VIN, SGND, or LX.
 Recommend connecting pin 13 to LX for compatibility to ISL8013.

ISL8014AEVAL2Z Bill of Materials

PART NUMBER	QTY	REFERENCE DESIGNATOR	DESCRIPTION	MANUFACTURER	MANUFACTURER PART
ISL8014AEVAL2Z	1		PWB-PCB, ISL8014AEVAL2Z, REVA, ROHS		ISL8014AEVAL2ZREVAPCB
H1045-00470-50V5-T	1	C4	CAP, SMD, 0603, 47pF, 50V, 5%, NPO, ROHS	AVX PHILLIPS	06035A470JAT2A 0603X7R500-562KNE
H1045-DNP	0	C3	CAP, SMD, 0603, DNP-PLACE HOLDER, ROHS		
H1065-00226-6R3V10-T	4	C1, C2, C5, C6	CAP, SMD, 1206, 22μF, 6.3V, 10%, X5R, ROHS	MURATA KEMET AVX	GRM31CR60J226KE19L C1206C226K9PACTU 12066D226KAT2A
DR73-1R5-R	1	L1	COIL-PWR INDUCTOR, SMD, 7.5mm, 1.5μH, 20%, 6.52A, ROHS	COOPER ELECTRONIC TECH.	DR73-1R5-R
131-4353-00	2	J1, J2	CONN-SCOPE PROBE TEST PT, COMPACT, PCB MNT, ROHS	TEKTRONIX	131-4353-00
1514-2	4	P4, P5, P7, P8	CONN-TURRET, TERMINAL POST, TH, ROHS	KEYSTONE	1514-2
5002	3	P2, P3, P6	CONN-MINI TEST POINT, VERTICAL, WHITE, ROHS	KEYSTONE	5002
LTST-C170CKT	1	D1	LED-GaAs RED, SMD, 2mmx1.25mm, 100mW, 40mA, 10mcd, ROHS	LITEON/VISHAY ROHM STANLEY ELECTRIC	LTST-C170CKT SML-210LTT86 BR112H-TR
ISL8014AIRZ	1	U1	IC-4A, 1MHz, BUCK REGULATOR, 16P, QFN, 4x4, ROHS	INTERSIL	ISL8014AIRZ
2N7002-7-F-T	1	Q1	TRANSISTOR, N-CHANNEL, 3LD, SOT-23, 60V, 115mA, ROHS	DIODES, INC. ON SEMICONDUCTOR	2N7002-7-F 2N7002LT1G
H2511-00R00-1/10W-T	1	R10	RESISTOR, SMD, 0603, 0Ω, 1/10W, TF, ROHS		
H2511-01003-1/10W1-T	4	R2, R4, R6, R7	RES, SMD, 0603, 100k, 1/10W, 1%, TF, ROHS		
H2511-01243-1/10W1-T	1	R1	RES, SMD, 0603, 124k, 1/10W, 1%, TF, ROHS	YAGEO PANASONIC	9C06031A1243FKHFT ERJ-3EK1243V
H2511-02001-1/10W1-T	1	R5	RES, SMD, 0603, 2k, 1/10W, 1%, TF, ROHS	KOA VENKEL	RK73H1JT2D2001F CR0603-10W-2001FT
H2511-DNP	0	R8, R9	RES, SMD, 0603, DNP-PLACE HOLDER, ROHS		
GT11MSCBE-T	2	SW1, SW2	SWITCH-TOGGLE, SMD, ULTRAMINI, 1P, SPST MINI	C&K COMPONENTS	GT11MSCKE
LABEL-SERIAL NUMBER	1		LABEL, FOR SERIAL NUMBER AND BOM REV #		

ISL8014AEVAL2Z Board Layout

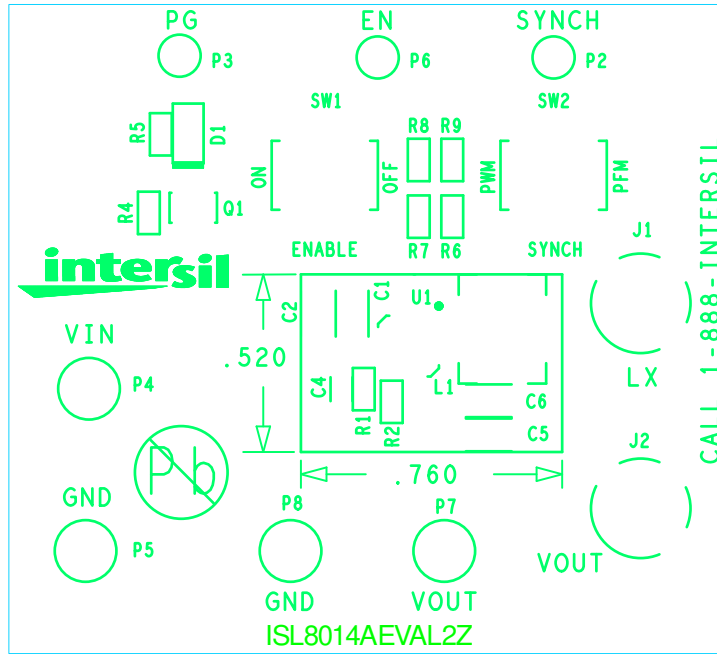

FIGURE 1. TOP COMPONENTS

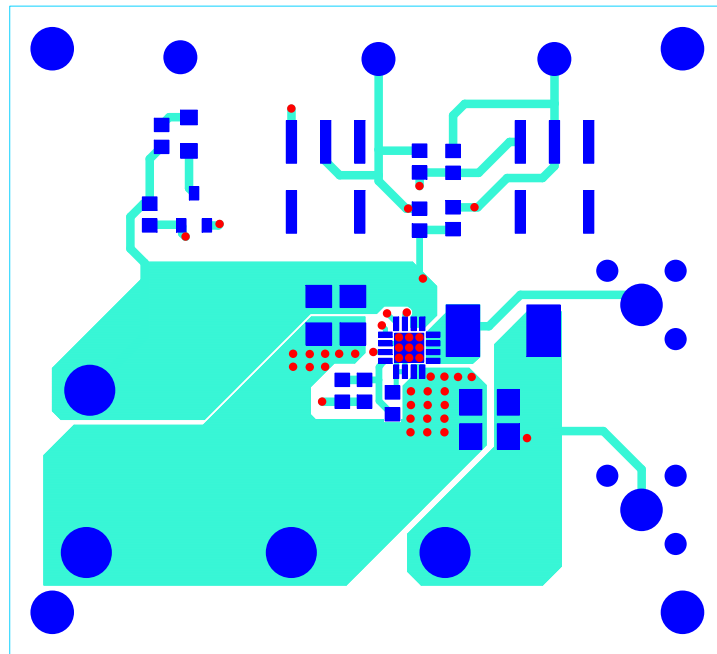

FIGURE 2. TOP LAYER ETCH

ISL8014AEVAL2Z Board Layout (Continued)

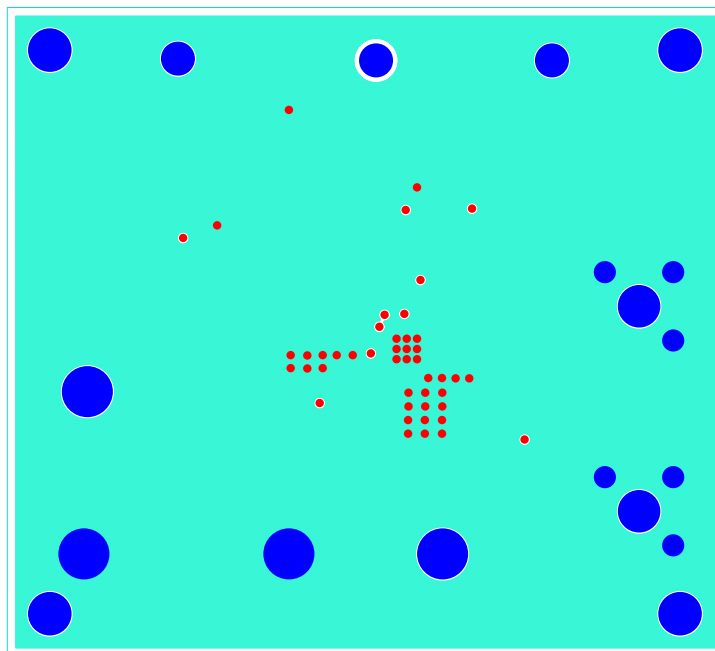

FIGURE 3. 2ND LAYER ETCH

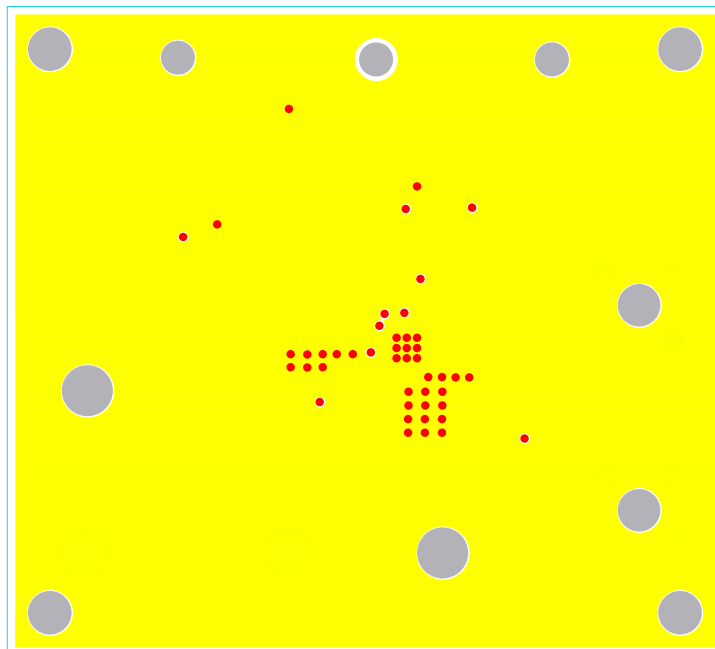

FIGURE 4. 3RD LAYER ETCH

ISL8014AEVAL2Z Board Layout (Continued)

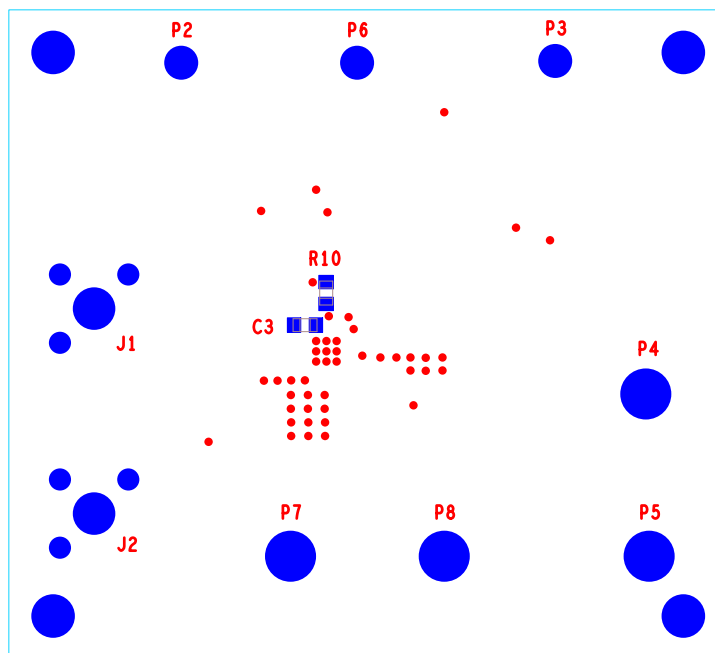

FIGURE 5. BOTTOM LAYER COMPONENTS (MIRRORS)

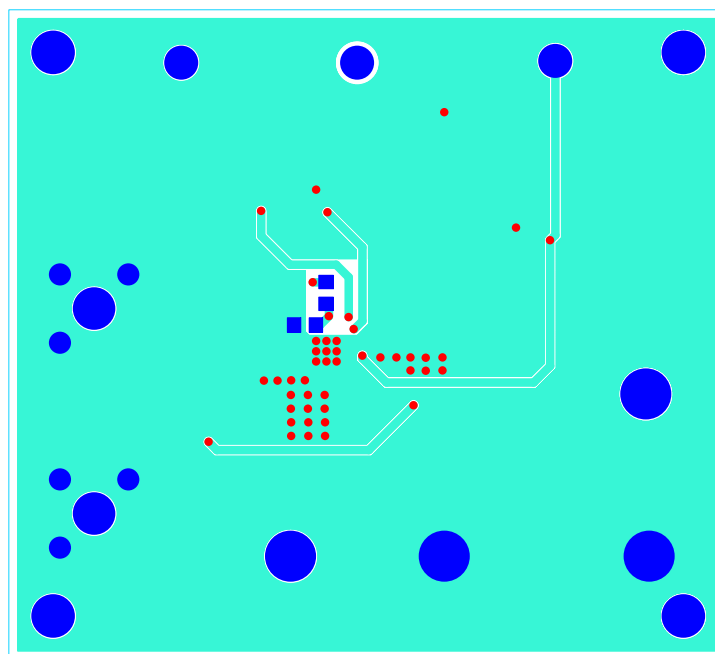

FIGURE 6. BOTTOM LAYER ETCH (MIRROR)

Notice

1. Descriptions of circuits, software and other related information in this document are provided only to illustrate the operation of semiconductor products and application examples. You are fully responsible for the incorporation or any other use of the circuits, software, and information in the design of your product or system. Renesas Electronics disclaims any and all liability for any losses and damages incurred by you or third parties arising from the use of these circuits, software, or information.
2. Renesas Electronics hereby expressly disclaims any warranties against and liability for infringement or any other claims involving patents, copyrights, or other intellectual property rights of third parties, by or arising from the use of Renesas Electronics products or technical information described in this document, including but not limited to, the product data, drawings, charts, programs, algorithms, and application examples.
3. No license, express, implied or otherwise, is granted hereby under any patents, copyrights or other intellectual property rights of Renesas Electronics or others.
4. You shall not alter, modify, copy, or reverse engineer any Renesas Electronics product, whether in whole or in part. Renesas Electronics disclaims any and all liability for any losses or damages incurred by you or third parties arising from such alteration, modification, copying or reverse engineering.
5. Renesas Electronics products are classified according to the following two quality grades: "Standard" and "High Quality". The intended applications for each Renesas Electronics product depends on the product's quality grade, as indicated below.
"Standard": Computers; office equipment; communications equipment; test and measurement equipment; audio and visual equipment; home electronic appliances; machine tools; personal electronic equipment; industrial robots; etc.
"High Quality": Transportation equipment (automobiles, trains, ships, etc.); traffic control (traffic lights); large-scale communication equipment; key financial terminal systems; safety control equipment; etc.
Unless expressly designated as a high reliability product or a product for harsh environments in a Renesas Electronics data sheet or other Renesas Electronics document, Renesas Electronics products are not intended or authorized for use in products or systems that may pose a direct threat to human life or bodily injury (artificial life support devices or systems; surgical implantations; etc.), or may cause serious property damage (space system; undersea repeaters; nuclear power control systems; aircraft control systems; key plant systems; military equipment; etc.). Renesas Electronics disclaims any and all liability for any damages or losses incurred by you or any third parties arising from the use of any Renesas Electronics product that is inconsistent with any Renesas Electronics data sheet, user's manual or other Renesas Electronics document.
6. When using Renesas Electronics products, refer to the latest product information (data sheets, user's manuals, application notes, "General Notes for Handling and Using Semiconductor Devices" in the reliability handbook, etc.), and ensure that usage conditions are within the ranges specified by Renesas Electronics with respect to maximum ratings, operating power supply voltage range, heat dissipation characteristics, installation, etc. Renesas Electronics disclaims any and all liability for any malfunctions, failure or accident arising out of the use of Renesas Electronics products outside of such specified ranges.
7. Although Renesas Electronics endeavors to improve the quality and reliability of Renesas Electronics products, semiconductor products have specific characteristics, such as the occurrence of failure at a certain rate and malfunctions under certain use conditions. Unless designated as a high reliability product or a product for harsh environments in a Renesas Electronics data sheet or other Renesas Electronics document, Renesas Electronics products are not subject to radiation resistance design. You are responsible for implementing safety measures to guard against the possibility of bodily injury, injury or damage caused by fire, and/or danger to the public in the event of a failure or malfunction of Renesas Electronics products, such as safety design for hardware and software, including but not limited to redundancy, fire control and malfunction prevention, appropriate treatment for aging degradation or any other appropriate measures. Because the evaluation of microcomputer software alone is very difficult and impractical, you are responsible for evaluating the safety of the final products or systems manufactured by you.
8. Please contact a Renesas Electronics sales office for details as to environmental matters such as the environmental compatibility of each Renesas Electronics product. You are responsible for carefully and sufficiently investigating applicable laws and regulations that regulate the inclusion or use of controlled substances, including without limitation, the EU RoHS Directive, and using Renesas Electronics products in compliance with all these applicable laws and regulations. Renesas Electronics disclaims any and all liability for damages or losses occurring as a result of your noncompliance with applicable laws and regulations.
9. Renesas Electronics products and technologies shall not be used for or incorporated into any products or systems whose manufacture, use, or sale is prohibited under any applicable domestic or foreign laws or regulations. You shall comply with any applicable export control laws and regulations promulgated and administered by the governments of any countries asserting jurisdiction over the parties or transactions.
10. It is the responsibility of the buyer or distributor of Renesas Electronics products, or any other party who distributes, disposes of, or otherwise sells or transfers the product to a third party, to notify such third party in advance of the contents and conditions set forth in this document.
11. This document shall not be reprinted, reproduced or duplicated in any form, in whole or in part, without prior written consent of Renesas Electronics.
12. Please contact a Renesas Electronics sales office if you have any questions regarding the information contained in this document or Renesas Electronics products.
(Note 1) "Renesas Electronics" as used in this document means Renesas Electronics Corporation and also includes its directly or indirectly controlled subsidiaries.
(Note 2) "Renesas Electronics product(s)" means any product developed or manufactured by or for Renesas Electronics.

(Rev.4.0-1 November 2017)



SALES OFFICES

Renesas Electronics Corporation

<http://www.renesas.com>

Refer to "<http://www.renesas.com/>" for the latest and detailed information.

Renesas Electronics America Inc.
1001 Murphy Ranch Road, Milpitas, CA 95035, U.S.A.
Tel: +1-408-432-8888, Fax: +1-408-434-5351

Renesas Electronics Canada Limited
9251 Yonge Street, Suite 8309 Richmond Hill, Ontario Canada L4C 9T3
Tel: +1-905-237-2004

Renesas Electronics Europe Limited
Dukes Meadow, Millboard Road, Bourne End, Buckinghamshire, SL8 5FH, U.K
Tel: +44-1628-651-700, Fax: +44-1628-651-804

Renesas Electronics Europe GmbH
Arcadiastrasse 10, 40472 Düsseldorf, Germany
Tel: +49-211-6503-0, Fax: +49-211-6503-1327

Renesas Electronics (China) Co., Ltd.
Room 1709 Quantum Plaza, No.27 ZhichunLu, Haidian District, Beijing, 100191 P. R. China
Tel: +86-10-8235-1155, Fax: +86-10-8235-7679

Renesas Electronics (Shanghai) Co., Ltd.
Unit 301, Tower A, Central Towers, 555 Langao Road, Putuo District, Shanghai, 200333 P. R. China
Tel: +86-21-2226-0888, Fax: +86-21-2226-0999

Renesas Electronics Hong Kong Limited
Unit 1601-1611, 16/F., Tower 2, Grand Century Place, 193 Prince Edward Road West, Mongkok, Kowloon, Hong Kong
Tel: +852-2265-6688, Fax: +852-2886-9022

Renesas Electronics Taiwan Co., Ltd.
13F, No. 363, Fu Shing North Road, Taipei 10543, Taiwan
Tel: +886-2-8175-9600, Fax: +886-2-8175-9670

Renesas Electronics Singapore Pte. Ltd.
80 Bendemeer Road, Unit #06-02 Hyflux Innovation Centre, Singapore 339949
Tel: +65-6213-0200, Fax: +65-6213-0300

Renesas Electronics Malaysia Sdn.Bhd.
Unit 1207, Block B, Menara Amcorp, Amcorp Trade Centre, No. 18, Jln Persiaran Barat, 46050 Petaling Jaya, Selangor Darul Ehsan, Malaysia
Tel: +60-3-7955-9390, Fax: +60-3-7955-9510

Renesas Electronics India Pvt. Ltd.
No.777C, 100 Feet Road, HAL 2nd Stage, Indiranagar, Bangalore 560 038, India
Tel: +91-80-67208700, Fax: +91-80-67208777

Renesas Electronics Korea Co., Ltd.
17F, KAMCO Yangjae Tower, 262, Gangnam-daero, Gangnam-gu, Seoul, 06265 Korea
Tel: +82-2-558-3737, Fax: +82-2-558-5338