

LOC	DIST	REVISIONS			
P	LTR	DESCRIPTION	DATE	OWN	APVD
DW	-	B	ECR-12-012115	26OCT12	EL WK

LED CURRENT DIAGRAM					
LED 1			LED 2		
NODE	COLOR		NODE	COLOR	
9(-)	10(+)	GREEN	12(+)	13(-)	YELLOW
11(-)	10(+)	ORANGE			
9(-)&11(-)	10(+)	YELLOW			

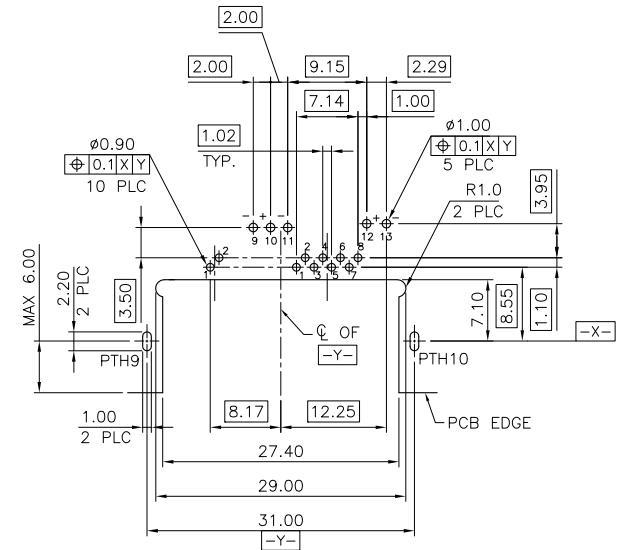

RECOMMENDED PCB LAYOUT (THICKNESS: 1.2mm)
 DIMENSION TOLERANCE: (1 PLC: ±0.1 2PLC: ±0.05)
 TOP VIEW

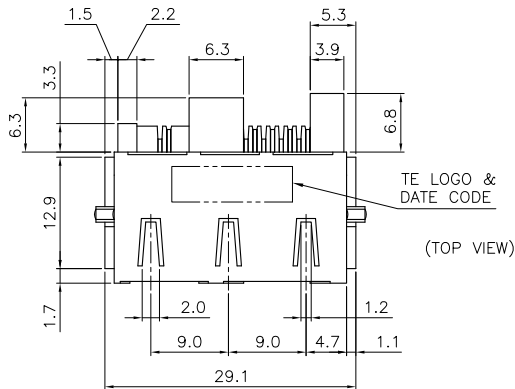
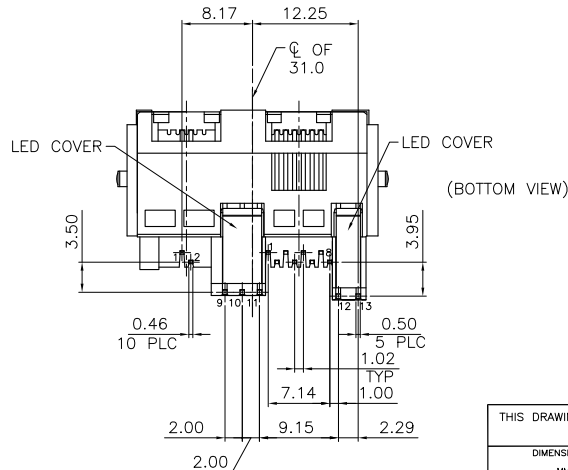
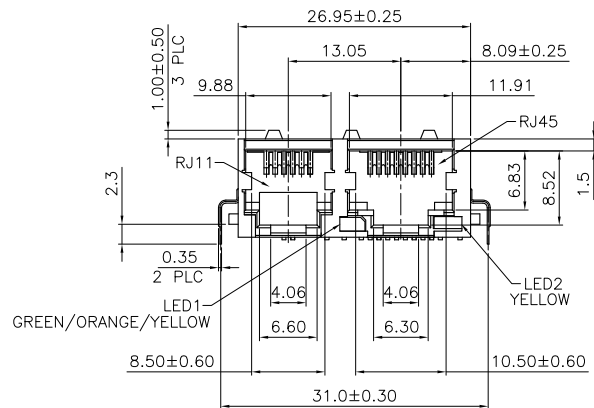
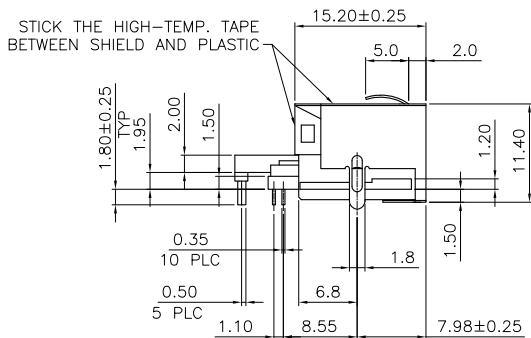

- NOTE:
- MATERIAL:
 HOUSING: PA9T WITH 33% GF, UL94 V-0, COLOR: BLACK.
 LED COVER: PA46 WITH 30% GF, UL94 V-0, COLOR: BLACK.
 CONTACTS: PHOSPHOR BRONZE.
 SHELL: BRASS.
 LED SOLDER TAIL: COLD ROLLED STEEL SHEET.
 - FINISH:
 CONTACTS: (SEE TABLE) GOLD PLATED ON CONTACT AREA, GOLD FLASH ON SOLDER TAIL, WITH ENTIRE CONTACT UNDERPLATED 1.27µm [50µ"] MIN. NICKEL.
 SHELL: 0.508µm [20µ"] MIN. NICKEL PLATED.
 LED SOLDER TAIL: 2.159µm [85µ"] MIN. TIN PLATED.
 - REFLOW SOLDER CAPABLE TO 260°C AS PER TE SPEC. 109-201, CONDITION B.

OBSOLETE	1.27µm [50µ"]	-1775754-4-
	0.762µm [30µ"]	1775754-3
OBSOLETE	0.381µm [15µ"]	-1775754-2-
OBSOLETE	0.152µm [6µ"]	-1775754-1-
	MIN. GOLD THICKNESS	PART NUMBER

THIS DRAWING IS A CONTROLLED DOCUMENT.		DWN T. KUO 17JUL2008 CHK A. WU 17JUL2008 APVD W. KODAMA 17JUL2008	TE TE Connectivity	
DIMENSIONS: MM 	TOLERANCES UNLESS OTHERWISE SPECIFIED: 0 PLC ± 1 PLC ±0.3 2 PLC ±0.25 3 PLC ±0.15 4 PLC ± ANGLES ±°	PRODUCT SPEC: 108-57701 APPLICATION SPEC	NAME MODULAR JACK, RJ45+RJ11, WITH LED, BOTTOM MOUNT, DIP TYPE.	
MATERIAL	FINISH	WEIGHT	SIZE	RESTRICTED TO
SEE NOTE	SEE NOTE	5.35 GRAMS	A200779 C=1775754	-
CUSTOMER DRAWING		SCALE	SHEET	REV
			1 OF 2	B

THIS DRAWING IS UNPUBLISHED. RELEASED FOR PUBLICATION
 © COPYRIGHT BY TYCO ELECTRONICS CORPORATION. ALL RIGHTS RESERVED.

LOC	DIST	REVISIONS			
P	LTR	DESCRIPTION	DATE	OWN	APVD
DW	-	SEE SHEET 1.			

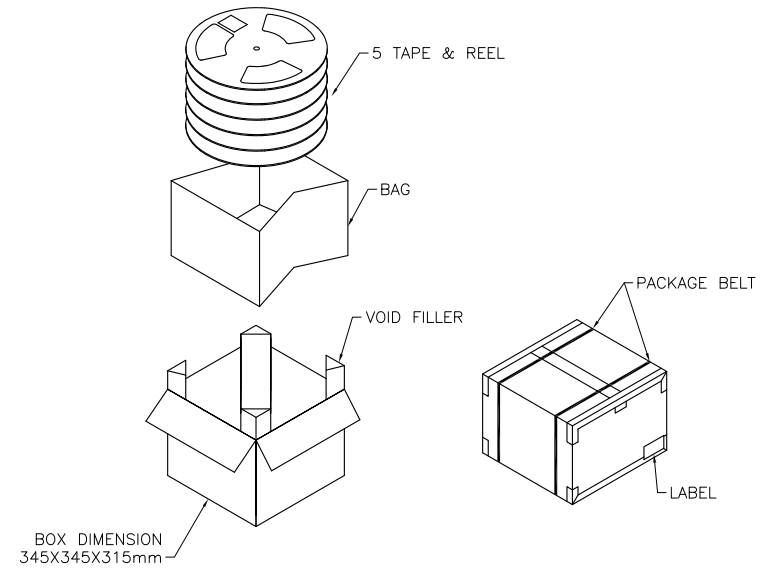
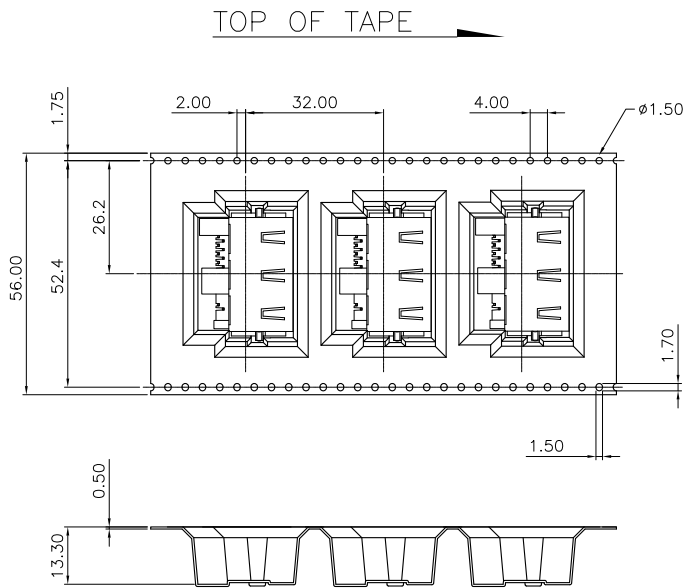
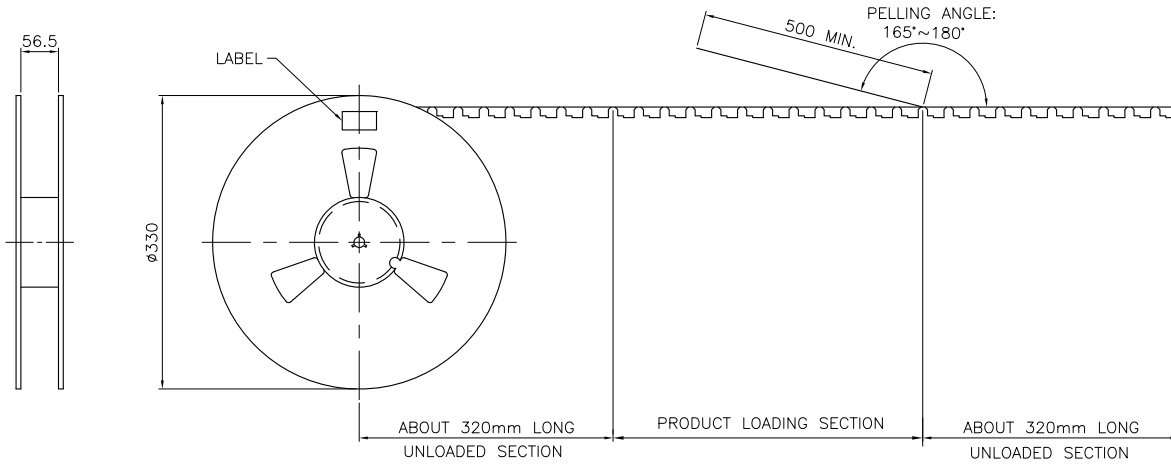

6 Kg	4 Kg	150	5	750 PCS
GROSS WEIGHT (REF.)	NET WEIGHT (REF.)	PCS/TAPE	REELS/BOX	QUANTITY

THIS DRAWING IS A CONTROLLED DOCUMENT.

DWN T. KUO 17JUL2008	 TE Connectivity MODULAR JACK, RJ45+RJ11, WITH LED, BOTTOM MOUNT, DIP TYPE.
CHK A. WU 17JUL2008	
APVD W. KODAMA 17JUL2008	
NAME	
DIMENSIONS: MM	PRODUCT SPEC
TOLERANCES UNLESS OTHERWISE SPECIFIED:	APPLICATION SPEC
0 PLC ±	WEIGHT
1 PLC ±	A200779 C=1775754
2 PLC ±	CUSTOMER DRAWING
3 PLC ±	SCALE
4 PCS ±	SHEET 2 OF 2
ANGLES ±	REV B