

NOTES:

1.  $\text{\textcircled{C}}$  REPRESENTS A CRITICAL DIMENSION.
2. BURR ALLOWANCE 0.038 [0.015] MAX
3. MINIMUM PUSHOUT FORCE: 4.45N [1.000LB]
4. POSITION 1 WILL MATE TO POSITION N.
5. NOTE DELETED.
6. MAX MATING/UN-MATING ANGLE: 5°
7. PARTS TO BE PACKAGED IN TRAYS.
8. ORDERS WILL BE PACKAGED ACCORDING TO THE SAMTEC PACKAGING EFFICIENCY STANDARDS(SPES) FOUND ON WWW.SAMTEC.COM.
9. ATTACH LABEL TO EACH REEL.

DESIGNED & DIMENSIONED IN MILLIMETERS[INCHES]

**No OF POSITIONS**  
 -02: USE MPPT-02-RA-XX  
 -04: USE MPPT-04-RA-XX  
 -06: USE MPPT-06-RA-XX  
 -08: USE MPPT-08-RA-XX  
 -10: USE MPPT-10-RA-XX

**TAPE & REEL**  
 (SEE NOTES 7,8 & 9)  
 BLANK: STANDARD  
 -TR: TAPE & REEL  
 -FR: FULL REEL QTY TAPE & REEL

**LEAD STYLE**  
 -01

**OPTION**  
 -SD: SCREW DOWN

**TAIL LENGTH**  
 -01: FOR 1.57 [0.062] THICK PCB (USE SUB-T-1M40-01-X AND SUB-C-215-01-X)  
 -02: FOR 2.36 [0.093] THICK PCB (USE SUB-T-1M40-03-X AND SUB-C-215-04-X)

**RIGHT ANGLE**

**PLATING**  
 -L: LIGHT SELECTIVE GOLD/MATTE TIN TAIL  
 -T: MATTE TIN ALL OVER

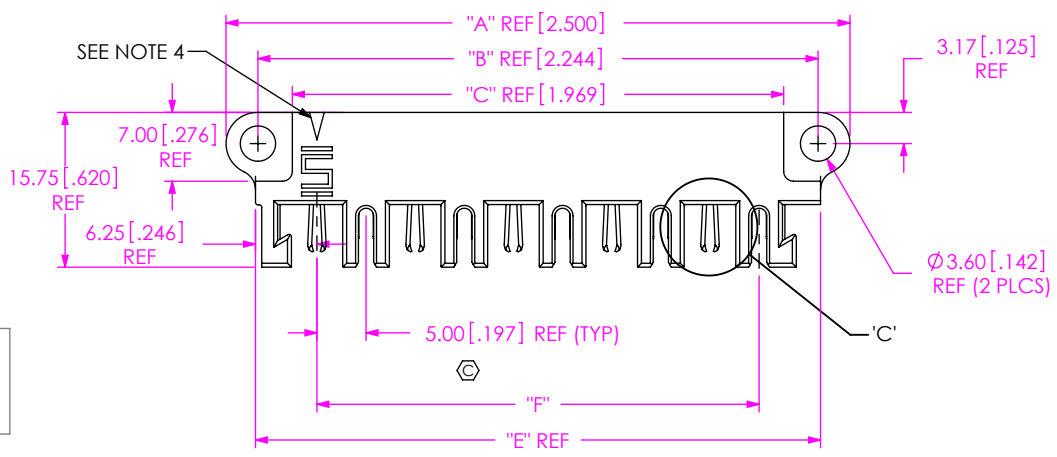

DO NOT SCALE FROM THIS PRINT

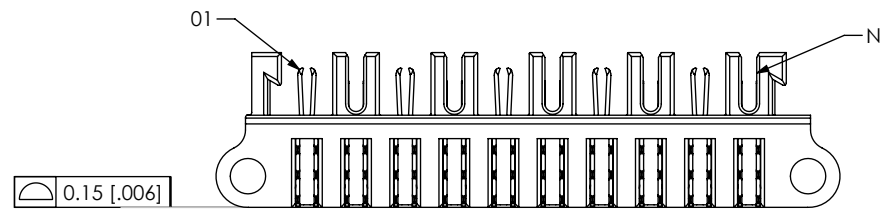
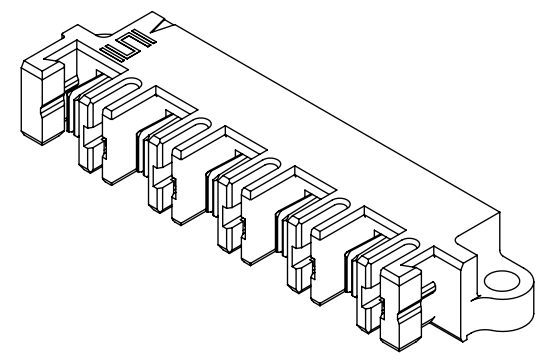
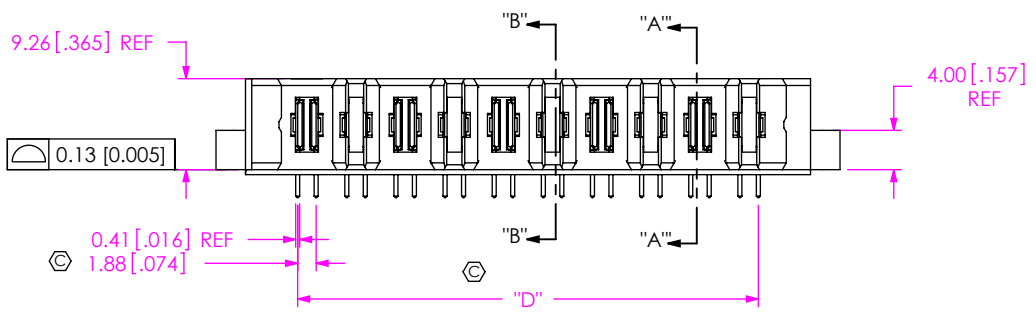

FIG 1 (MPPT-10-01-X-RA-SD SHOWN)

UNLESS OTHERWISE SPECIFIED, DIMENSIONS ARE IN MILLIMETERS.  
 TOLERANCES ARE:  
 DECIMALS ANGLES  
 X.X: ±0.3 [0.1]  
 X.XX: ±0.13 [0.05]  
 X.XXX: ±0.05 [0.020]

**PROPRIETARY NOTE**  
 THIS DOCUMENT CONTAINS INFORMATION CONFIDENTIAL AND PROPRIETARY TO SAMTEC, INC. AND SHALL NOT BE REPRODUCED OR TRANSFERRED TO OTHER DOCUMENTS OR DISCLOSED TO OTHERS OR USED FOR ANY PURPOSE OTHER THAN THAT WHICH IT WAS OBTAINED WITHOUT THE EXPRESSED WRITTEN CONSENT OF SAMTEC, INC.



520 PARK EAST BLVD, NEW ALBANY, IN 47150  
 PHONE: 812-944-6733 FAX: 812-948-5047  
 e-Mail: info@SAMTEC.com code 55322

TABLE 1																		
No. OF POSITIONS	"A"	"B"	"C"	"D"	"E"	"F"	"G"											
-02	23.50	0.925	17.00	0.669	10.00	0.394	6.88	0.271	17.50	0.689	5.00	0.551						
-04	33.50	1.319	27.00	1.063	20.00	0.787	16.88	0.665	27.50	1.083	15.00	0.591	24.00	0.945				
-06	43.50	1.713	37.00	1.457	30.00	1.181	26.88	1.058	37.50	1.476	25.00	0.984	34.00	1.339				
-08	53.50	2.106	47.00	1.850	40.00	1.575	36.88	1.452	47.50	1.870	35.00	1.378	44.00	1.732				
-10	63.50	2.500	57.00	2.244	50.00	1.969	46.88	1.846	57.50	2.264	45.00	1.772	54.00	2.126				

**MATERIAL:** DO NOT SCALE DRAWING SHEET SCALE: 1:1

INSULATOR: LCP, COLOR: BLACK  
 CONTACT AND TERMINAL: COPPER ALLOY.

**DESCRIPTION:**  
 5mm RA POWER CONNECTOR BODY  
**DWG. NO.**  
 MPPT-XX-01-XX-X-RA-SD-XX  
**BY:** B RAY 08/18/2009 SHEET 1 OF 2

TABLE 2			
TAIL LENGTH	"H"	SUB-C-215-XX-X	SUB-T-1M40-XX-X
MPPT-XX-01-01-X-RA-XX-XX	2.84 [0.112]	SUB-C-215-01-X	SUB-T-1M40-01-X
MPPT-XX-01-02-X-RA-XX-XX	3.63 [0.143]	SUB-C-215-04-X	SUB-T-1M40-03-X

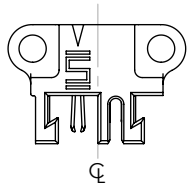
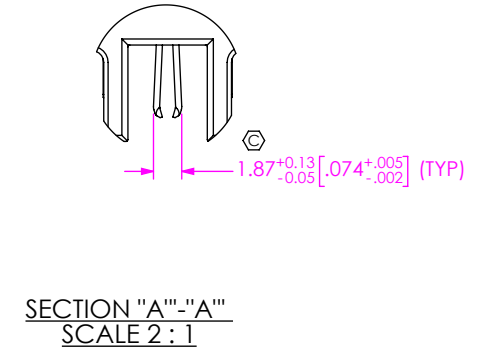
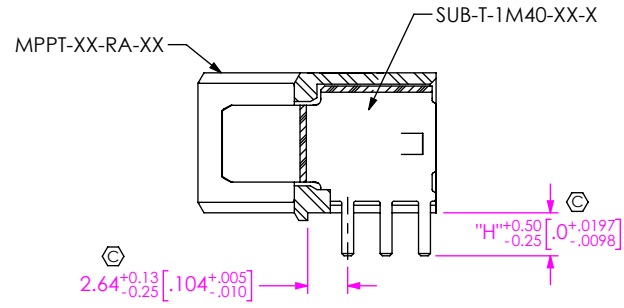
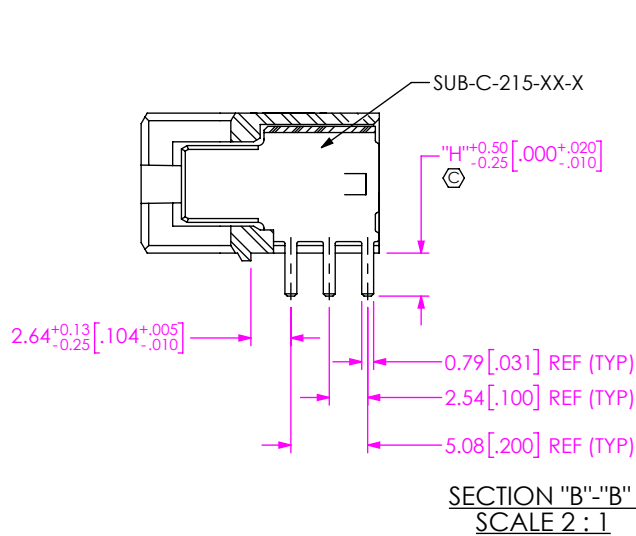

**FIG 2**  
(MPPT-02-01-01-X-RA-SD SHOWN)  
(SAME AS FIG 1, DIFFERENT AS SHOWN)

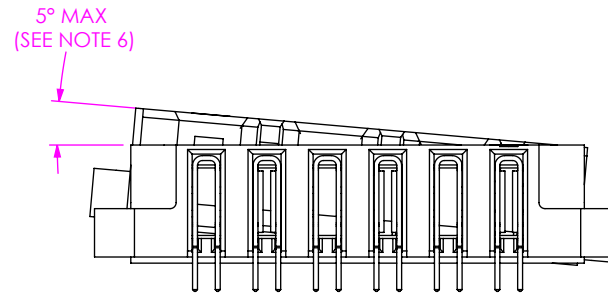

**FIG 4**  
(MPPT-06-01-01-X-RA-SD SHOWN)  
(SEE NOTE 6)

**PROPRIETARY NOTE**  
THIS DOCUMENT CONTAINS INFORMATION CONFIDENTIAL AND PROPRIETARY TO SAMTEC, INC. AND SHALL NOT BE REPRODUCED OR TRANSFERRED TO OTHER DOCUMENTS OR DISCLOSED TO OTHERS OR USED FOR ANY PURPOSE OTHER THAN THAT WHICH IT WAS OBTAINED WITHOUT THE EXPRESSED WRITTEN CONSENT OF SAMTEC, INC.

DO NOT SCALE DRAWING

SHEET SCALE: 1:1

**samtec**

520 PARK EAST BLVD, NEW ALBANY, IN 47150  
PHONE: 812-944-6733 FAX: 812-948-5047  
e-Mail: info@SAMTEC.com code 55322

DESCRIPTION:  
5mm RA POWER CONNECTOR BODY

DWG. NO.  
**MPPT-XX-01-XX-X-RA-SD-XX**

BY: B RAY 08/18/2009 SHEET 2 OF 2