

- 1
- 2
- 3
- 4
- 5
- 6
- 7
- 8
- 9
- 10
- 11
- 12
- 13
- 14
- 15
- 16
- 17
- 18

LEVER BODY

Glass-fibre reinforced polyamide based (PA) technopolymer, grey-black colour, matte finish.

PUSH BUTTON

Technopolymer in Ergostyle colours, glossy finish.

STANDARD EXECUTIONS

Glass-fibre reinforced technopolymer clamping element with retaining pin, black colour, with knurling on the protruding part to make initial tightening easier. AISI 302 stainless steel return spring.

- **ERW-B:** brass boss, threaded blind hole.
- **ERW-SST:** AISI 303 stainless steel boss, threaded blind hole.
- **ERW-p:** zinc-plated steel threaded stud, chamfered flat end UNI 947 : ISO 4753 (see Technical data on page A-11).
- **ERW-SST-p:** AISI 303 stainless steel threaded stud, chamfered flat end UNI 947 : ISO 4753 (see Technical data on page A-11).

FEATURES AND APPLICATIONS

Particularly suitable when the available space and operating mode make it preferable to use a flat lever instead of an inclined lever.

Compared to other types of adjustable handles with metal retaining screw this solution offers some advantages:

- absolute electric insulation for the operator
- no visible steel parts subject to rust
- more comfortable lever release.

STRESS RESISTANCE

Adjustable handles are generally used for repetitive clamping operations sometimes with very high-frequency.

Therefore, the stress resistance (i.e. the resistance to repeated tightening cycles) of the handle unit is particularly important and, especially, the strength of the toothed element which transmits the tightening force from the handle to the threaded element (boss or stud).

The results of several laboratory tests, performed with a special instrument that simulates the stress resistance conditions, have shown that e.g. ERW.78 adjustable handle can withstand without yielding more than 100,000 tightening cycles, under the action of a force of 490 N (see graphic).

The special glass-fibre reinforced technopolymer enables the ELESAs adjustable handles to guarantee stress resistance values which are much higher than the ones generated under normal working conditions.

INSTRUCTIONS OF USE

For clamping, lift the lever to disengage the clamping device teeth and bring it back to start position. By releasing the lever, the return spring automatically engages the teeth.



ERGOSTYLE® ELESAs Original design

NUMBER OF TIGHTENINGS

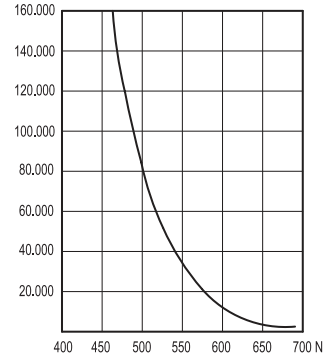

Conversion Table 1 mm = 0.039 inch	
mm	inch
22	0.86
30	1.18
44	1.73
63	2.48
78	3.07

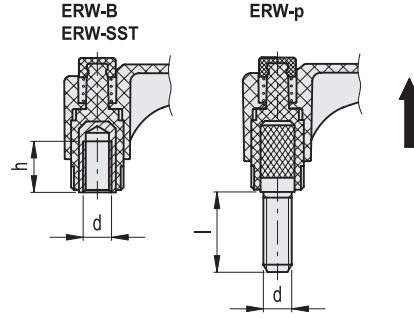
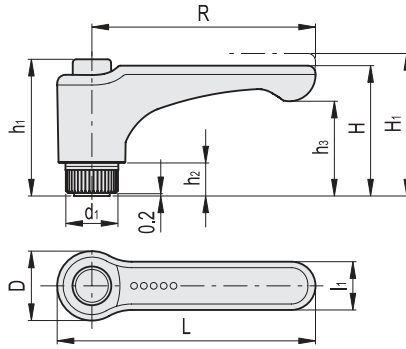

* Complete with colour index, example: 253061-C2 ERW.30-B-M3-C2

- C1 RAL7021
- C2 RAL2004
- C3 RAL7035
- C4 RAL1021
- C5 RAL5024
- C6 RAL3000
- C17 RAL6017

METRIC

ERW-B

Code	Description	R	d6H	L	D	H	H1	h	h1	h2	h3	d1	l1	Teeth no.	⚖️
252801-*	ERW.22-B-M3-*	22	M3	29	14	26	29.5	6	28.5	6	19	10.5	8.5	16	7
252806-*	ERW.22-B-M4-*	22	M4	29	14	26	29.5	10	28.5	6	19	10.5	8.5	16	8
252811-*	ERW.22-B-M5-*	22	M5	29	14	26	29.5	10	28.5	6	19	10.5	8.5	16	9
253061-*	ERW.30-B-M3-*	30	M3	37.5	15.5	27	30.5	10	29.5	6	20.5	12	9	18	8
253066-*	ERW.30-B-M4-*	30	M4	37.5	15.5	27	30.5	10	29.5	6	20.5	12	9	18	9
253071-*	ERW.30-B-M5-*	30	M5	37.5	15.5	27	30.5	10	29.5	6	20.5	12	9	18	10
253076-*	ERW.30-B-M6-*	30	M6	37.5	15.5	27	30.5	10	29.5	6	20.5	12	9	18	11
253101-*	ERW.44-B-M5-*	44	M5	52	15.5	27	30.5	10	29.5	6	18.5	12	11	18	12
253106-*	ERW.44-B-M6-*	44	M6	52	15.5	27	30.5	10	29.5	6	18.5	12	11	18	16
253131-*	ERW.63-B-M6-*	63	M8	73.5	19	36.5	40	16	37.5	8	26.5	15	13.5	20	22
253136-*	ERW.63-B-M8-*	63	M8	73.5	19	36.5	40	13	37.5	8	26.5	15	13.5	20	31
253139-*	ERW.63-B-M10-*	63	M10	73.5	19	36.5	40	13	37.5	8	26.5	15	13.5	20	29
253151-*	ERW.78-B-M8-*	78	M8	90.5	24.5	42	45.5	20	47	12	30	19	16	24	40
253156-*	ERW.78-B-M10-*	78	M10	90.5	24.5	42	45.5	20	47	12	30	19	16	24	43
253161-*	ERW.78-B-M12-*	78	M10	90.5	24.5	42	45.5	20	47	12	30	19	16	24	46

ERW-SST

INOX STAINLESS STEEL

METRIC

Code	Description	R	d6H	L	D	H	H1	h	h1	h2	h3	d1	l1	Teeth no.	⚖️
252821-*	ERW.22-SST-M3-*	22	M3	29	14	26	29.5	6	28.5	6	19	10.5	8.5	16	7
252826-*	ERW.22-SST-M4-*	22	M4	29	14	26	29.5	9	28.5	6	19	10.5	8.5	16	8
252831-*	ERW.22-SST-M5-*	22	M5	29	14	26	29.5	10	28.5	6	19	10.5	8.5	16	9
255071-*	ERW.30-SST-M5-*	30	M5	37.5	15.5	27	30.5	6	29.5	6	20.5	12	9	18	9
255076-*	ERW.30-SST-M6-*	30	M6	37.5	15.5	27	30.5	6	29.5	6	20.5	12	9	18	11
255101-*	ERW.44-SST-M5-*	44	M5	52	15.5	27	30.5	6	29.5	6	18.5	12	11	18	12
255106-*	ERW.44-SST-M6-*	44	M6	52	15.5	27	30.5	6	29.5	6	18.5	12	11	18	16
255131-*	ERW.63-SST-M6-*	63	M6	73.5	19	36.5	40	12	37.5	8	26.5	15	13.5	20	63
255136-*	ERW.63-SST-M8-*	63	M8	73.5	19	36.5	40	12	37.5	8	26.5	15	13.5	20	31
255151-*	ERW.78-SST-M8-*	78	M8	90.5	24.5	42	45.5	13	47	12	30	19	16	24	40
255156-*	ERW.78-SST-M10-*	78	M10	90.5	24.5	42	45.5	13	47	12	30	19	16	24	43

ERW-p

METRIC

Code	Description	R	d6g	L	D	H	H1	h1	h2	h3	d1	l	l1	Teeth no.	⚖️
252851-*	ERW.22-p-M3x10-*	22	M3	29	14	26	29.5	28.5	6	19	10.5	10	8.5	16	8
252856-*	ERW.22-p-M4x16-*	22	M4	29	14	26	29.5	28.5	6	19	10.5	16	8.5	16	9
252861*	ERW.22-p-M4x20-*	22	M4	29	14	26	29.5	28.5	6	19	10.5	20	8.5	16	10
252866-*	ERW.22-p-M5x16-*	22	M5	29	14	26	29.5	28.5	6	19	10.5	16	8.5	16	11
252871-*	ERW.22-p-M5x20-*	22	M5	29	14	26	29.5	28.5	6	19	10.5	20	8.5	16	12



Clamping handles

- 1
- 2
- 3
- 4
- 5
- 6
- 7
- 8
- 9
- 10
- 11
- 12
- 13
- 14
- 15
- 16
- 17
- 18

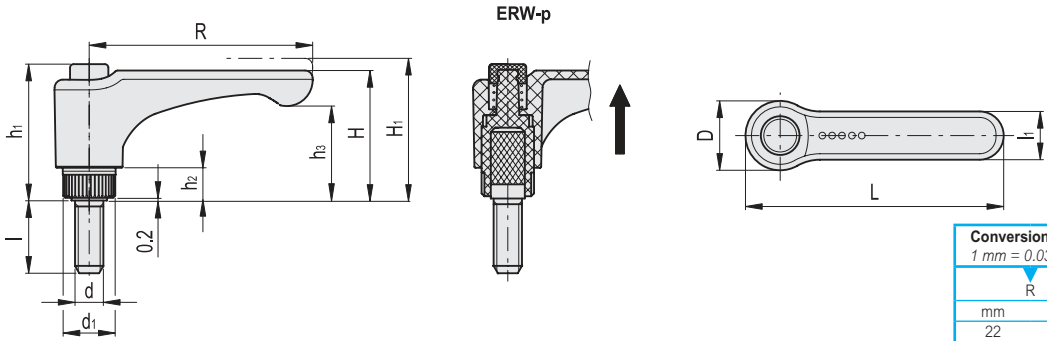

Conversion Table 1 mm = 0.039 inch	
R	
mm	inch
22	0.86
30	1.18
44	1.73
63	2.48
78	3.07



* Complete with colour index, example: 255071-C2 ERW.30-SST-M5-C2

- C1 RAL7021
- C2 RAL2004
- C3 RAL7035
- C4 RAL1021
- C5 RAL5024
- C6 RAL3000
- C17 RAL6017

METRIC

ERW-p

Code	Description	R	d6g	L	D	H	H1	h1	h2	h3	d1	l	l1	Teeth no.	
254001*	ERW.30-p-M5x10*	30	M5	37.5	15.5	27	30.5	29.5	6	20.5	12	10	9	18	10
254006*	ERW.30-p-M5x16*	30	M5	37.5	15.5	27	30.5	29.5	6	20.5	12	16	9	18	11
254011*	ERW.30-p-M5x20*	30	M5	37.5	15.5	27	30.5	29.5	6	20.5	12	20	9	18	11
254016*	ERW.30-p-M6x10*	30	M6	37.5	15.5	27	30.5	29.5	6	20.5	12	10	9	18	11
254021*	ERW.30-p-M6x16*	30	M6	37.5	15.5	27	30.5	29.5	6	20.5	12	16	9	18	12
254026*	ERW.30-p-M6x20*	30	M6	37.5	15.5	27	30.5	29.5	6	20.5	12	20	9	18	13
254031*	ERW.30-p-M6x25*	30	M6	37.5	15.5	27	30.5	29.5	6	20.5	12	25	9	18	14
254036*	ERW.30-p-M6x30*	30	M6	37.5	15.5	27	30.5	29.5	6	20.5	12	30	9	18	15
254046*	ERW.30-p-M6x40*	30	M6	37.5	15.5	27	30.5	29.5	6	20.5	12	40	9	18	16
254101*	ERW.44-p-M5x10*	44	M5	52	15.5	27	30.5	29.5	6	18.5	12	10	11	18	12
254106*	ERW.44-p-M5x16*	44	M5	52	15.5	27	30.5	29.5	6	18.5	12	16	11	18	13
254111*	ERW.44-p-M5x20*	44	M5	52	15.5	27	30.5	29.5	6	18.5	12	20	11	18	13
254116*	ERW.44-p-M6x10*	44	M6	52	15.5	27	30.5	29.5	6	18.5	12	10	11	18	13
254121*	ERW.44-p-M6x16*	44	M6	52	15.5	27	30.5	29.5	6	18.5	12	16	11	18	14
254126*	ERW.44-p-M6x20*	44	M6	52	15.5	27	30.5	29.5	6	18.5	12	20	11	18	15
254131*	ERW.44-p-M6x25*	44	M6	52	15.5	27	30.5	29.5	6	18.5	12	25	11	18	16
254136*	ERW.44-p-M6x30*	44	M6	52	15.5	27	30.5	29.5	6	18.5	12	30	11	18	17
254146*	ERW.44-p-M6x40*	44	M6	52	15.5	27	30.5	29.5	6	18.5	12	40	11	18	19
254151*	ERW.44-p-M6x45*	44	M6	52	15.5	27	30.5	29.5	6	18.5	12	45	11	18	20
254301*	ERW.63-p-M6x10*	63	M6	73.5	19	36.5	40	37.5	8	26.5	15	10	13.5	20	23
254306*	ERW.63-p-M6x16*	63	M6	73.5	19	36.5	40	37.5	8	26.5	15	16	13.5	20	24
254311*	ERW.63-p-M6x20*	63	M6	73.5	19	36.5	40	37.5	8	26.5	15	20	13.5	20	25
254316*	ERW.63-p-M6x25*	63	M6	73.5	19	36.5	40	37.5	8	26.5	15	25	13.5	20	26
254321*	ERW.63-p-M6x30*	63	M6	73.5	19	36.5	40	37.5	8	26.5	15	30	13.5	20	27
254323*	ERW.63-p-M6x35*	63	M6	73.5	19	36.5	40	37.5	8	26.5	15	35	13.5	20	29
254326*	ERW.63-p-M6x40*	63	M6	73.5	19	36.5	40	37.5	8	26.5	15	40	13.5	20	31
254333*	ERW.63-p-M8x16*	63	M8	73.5	19	36.5	40	37.5	8	26.5	15	16	13.5	20	29
254336*	ERW.63-p-M8x20*	63	M8	73.5	19	36.5	40	37.5	8	26.5	15	20	13.5	20	30
254341*	ERW.63-p-M8x25*	63	M8	73.5	19	36.5	40	37.5	8	26.5	15	25	13.5	20	31
254346*	ERW.63-p-M8x30*	63	M8	73.5	19	36.5	40	37.5	8	26.5	15	30	13.5	20	33
254351*	ERW.63-p-M8x35*	63	M8	73.5	19	36.5	40	37.5	8	26.5	15	35	13.5	20	35
254356*	ERW.63-p-M8x40*	63	M8	73.5	19	36.5	40	37.5	8	26.5	15	40	13.5	20	37
254361*	ERW.63-p-M8x45*	63	M8	73.5	19	36.5	40	37.5	8	26.5	15	45	13.5	20	38
254366*	ERW.63-p-M8x50*	63	M8	73.5	19	36.5	40	37.5	8	26.5	15	50	13.5	20	39
254371*	ERW.63-p-M8x60*	63	M8	73.5	19	36.5	40	37.5	8	26.5	15	60	13.5	20	42
254376*	ERW.63-p-M8x70*	63	M8	73.5	19	36.5	40	37.5	8	26.5	15	70	13.5	20	45
254378*	ERW.63-p-M8x80*	63	M8	73.5	19	36.5	40	37.5	8	26.5	15	80	13.5	20	48
254391*	ERW.63-p-M10x20*	63	M10	73.5	19	36.5	40	37.5	8	26.5	15	20	13.5	20	35
254393*	ERW.63-p-M10x30*	63	M10	73.5	19	36.5	40	37.5	8	26.5	15	30	13.5	20	38
254395*	ERW.63-p-M10x40*	63	M10	73.5	19	36.5	40	37.5	8	26.5	15	40	13.5	20	42
254397*	ERW.63-p-M10x50*	63	M10	73.5	19	36.5	40	37.5	8	26.5	15	50	13.5	20	44
254399*	ERW.63-p-M10x60*	63	M10	73.5	19	36.5	40	37.5	8	26.5	15	60	13.5	20	47

Clamping handles

METRIC

ERW-p

Code	Description	R	d6g	L	D	H	H1	h1	h2	h3	d1	l	l1	Teeth no.	⚖
254498-*	ERW.78-p-M8x20-*	78	M8	90.5	24.5	42	45.5	47	12	30	19	20	16	24	48
254501-*	ERW.78-p-M8x25-*	78	M8	90.5	24.5	42	45.5	47	12	30	19	25	16	24	49
254503-*	ERW.78-p-M8x30-*	78	M8	90.5	24.5	42	45.5	47	12	30	19	30	16	24	50
254506-*	ERW.78-p-M8x40-*	78	M8	90.5	24.5	42	45.5	47	12	30	19	40	16	24	52
254507-*	ERW.78-p-M8x45-*	78	M8	90.5	24.5	42	45.5	47	12	30	19	45	16	24	53
254509-*	ERW.78-p-M8x50-*	78	M8	90.5	24.5	42	45.5	47	12	30	19	50	16	24	54
254511-*	ERW.78-p-M8x55-*	78	M8	90.5	24.5	42	45.5	47	12	30	19	55	16	24	55
254513-*	ERW.78-p-M8x60-*	78	M8	90.5	24.5	42	45.5	47	12	30	19	60	16	24	56
254515-*	ERW.78-p-M8x70-*	78	M8	90.5	24.5	42	45.5	47	12	30	19	70	16	24	58
254516-*	ERW.78-p-M10x20-*	78	M10	90.5	24.5	42	45.5	47	12	30	19	20	16	24	55
254521-*	ERW.78-p-M10x25-*	78	M10	90.5	24.5	42	45.5	47	12	30	19	25	16	24	58
254526-*	ERW.78-p-M10x30-*	78	M10	90.5	24.5	42	45.5	47	12	30	19	30	16	24	60
254531-*	ERW.78-p-M10x35-*	78	M10	90.5	24.5	42	45.5	47	12	30	19	35	16	24	62
254536-*	ERW.78-p-M10x40-*	78	M10	90.5	24.5	42	45.5	47	12	30	19	40	16	24	65
254541-*	ERW.78-p-M10x50-*	78	M10	90.5	24.5	42	45.5	47	12	30	19	50	16	24	69
254546-*	ERW.78-p-M10x60-*	78	M10	90.5	24.5	42	45.5	47	12	30	19	60	16	24	74
254551-*	ERW.78-p-M10x70-*	78	M10	90.5	24.5	42	45.5	47	12	30	19	70	16	24	79
254561-*	ERW.78-p-M12x20-*	78	M12	90.5	24.5	42	45.5	47	12	30	19	20	16	24	64
254566-*	ERW.78-p-M12x25-*	78	M12	90.5	24.5	42	45.5	47	12	30	19	25	16	24	67
254571-*	ERW.78-p-M12x30-*	78	M12	90.5	24.5	42	45.5	47	12	30	19	30	16	24	70
254573-*	ERW.78-p-M12x35-*	78	M12	90.5	24.5	42	45.5	47	12	30	19	35	16	24	74
254576-*	ERW.78-p-M12x40-*	78	M12	90.5	24.5	42	45.5	47	12	30	19	40	16	24	77
254581-*	ERW.78-p-M12x45-*	78	M12	90.5	24.5	42	45.5	47	12	30	19	45	16	24	80
254586-*	ERW.78-p-M12x50-*	78	M12	90.5	24.5	42	45.5	47	12	30	19	50	16	24	84
254591-*	ERW.78-p-M12x60-*	78	M12	90.5	24.5	42	45.5	47	12	30	19	60	16	24	91
254593-*	ERW.78-p-M12x70-*	78	M12	90.5	24.5	42	45.5	47	12	30	19	70	16	24	98
254596-*	ERW.78-p-M12x80-*	78	M12	90.5	24.5	42	45.5	47	12	30	19	80	16	24	105

R	
mm	inch
22	0.86
30	1.18
44	1.73
63	2.48
78	3.07



*Complete with colour index, example: 255061-C2 ERW.30-SST-p-M5x10-C2

- C1 RAL7021
- C2 RAL2004
- C3 RAL7035
- C4 RAL1021
- C5 RAL5024
- C6 RAL3000
- C17 RAL6017

ERW-SST-p

INOX STAINLESS STEEL METRIC

Code	Description	R	d6g	L	D	H	H1	h1	h2	h3	d1	l	l1	Teeth no.	⚖
252881-*	ERW.22-SST-p-M3x10-*	22	M3	29	14	26	29.5	28.5	6	19	10	10	8.5	18	6
252886-*	ERW.22-SST-p-M4x16-*	22	M4	29	14	26	29.5	28.5	6	19	10	16	8.5	18	7
252891*	ERW.22-SST-p-M4x20-*	22	M4	29	14	26	29.5	28.5	6	19	10	20	8.5	18	8
252896-*	ERW.22-SST-p-M5x16-*	22	M5	29	14	26	29.5	28.5	6	19	10	16	8.5	18	9
252901-*	ERW.22-SST-p-M5x20-*	22	M5	29	14	26	29.5	28.5	6	19	10	20	8.5	18	10
255061-*	ERW.30-SST-p-M5x10-*	30	M5	37.5	15.5	27	30.5	29.5	6	20.5	12	10	9	18	10
255066-*	ERW.30-SST-p-M5x16-*	30	M5	37.5	15.5	27	30.5	29.5	6	20.5	12	16	9	18	11
255196-*	ERW.30-SST-p-M6x10-*	30	M6	37.5	15.5	27	30.5	29.5	6	20.5	12	10	9	18	11
255201-*	ERW.30-SST-p-M6x16-*	30	M6	37.5	15.5	27	30.5	29.5	6	20.5	12	16	9	18	12
255203-*	ERW.30-SST-p-M6x20-*	30	M6	37.5	15.5	27	30.5	29.5	6	20.5	12	20	9	18	13
255205-*	ERW.30-SST-p-M6x25-*	30	M6	37.5	15.5	27	30.5	29.5	6	20.5	12	25	9	18	14
255207-*	ERW.30-SST-p-M6x30-*	30	M6	37.5	15.5	27	30.5	29.5	6	20.5	12	30	9	18	15



Clamping handles

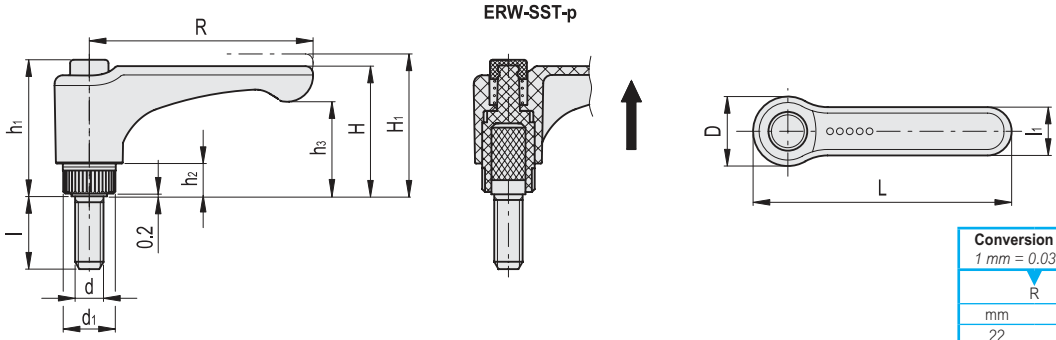

Conversion Table	
1 mm = 0.039 inch	
R	
mm	inch
22	0.86
30	1.18
44	1.73
63	2.48
78	3.07



* Complete with colour index, example: 255061-C2 ERW.30-SST-p-M5x10-C2

- C1 RAL7021
- C2 RAL2004
- C3 RAL7035
- C4 RAL1021
- C5 RAL5024
- C6 RAL3000
- C17 RAL6017

ERW-SST-p

INOX STAINLESS STEEL **METRIC**

Code	Description	R	d6g	L	D	H	H1	h1	h2	h3	d1	l	l1	Teeth no.	
255209*	ERW.44-SST-p-M5x10.*	44	M5	52	15.5	27	30.5	29.5	6	18.5	12	10	11	18	12
255211*	ERW.44-SST-p-M5x16.*	44	M5	52	15.5	27	30.5	29.5	6	18.5	12	16	11	18	13
255216*	ERW.44-SST-p-M6x10.*	44	M6	52	15.5	27	30.5	29.5	6	18.5	12	10	11	18	13
255221*	ERW.44-SST-p-M6x16.*	44	M6	52	15.5	27	30.5	29.5	6	18.5	12	16	11	18	14
255226*	ERW.44-SST-p-M6x20.*	44	M6	52	15.5	27	30.5	29.5	6	18.5	12	20	11	18	15
255231*	ERW.44-SST-p-M6x25.*	44	M6	52	15.5	27	30.5	29.5	6	18.5	12	25	11	18	16
255236*	ERW.44-SST-p-M6x30.*	44	M6	52	15.5	27	30.5	29.5	6	18.5	12	30	11	18	17
255341*	ERW.63-SST-p-M6x10.*	63	M6	73.5	19	36.5	40	37.5	8	26.5	15	10	13.5	20	23
255351*	ERW.63-SST-p-M6x20.*	63	M6	73.5	19	36.5	40	37.5	8	26.5	15	20	13.5	20	25
255421*	ERW.63-SST-p-M6x30.*	63	M6	73.5	19	36.5	40	37.5	8	26.5	15	30	13.5	20	27
255426*	ERW.63-SST-p-M6x40.*	63	M6	73.5	19	36.5	40	37.5	8	26.5	15	40	13.5	20	31
255431*	ERW.63-SST-p-M8x16.*	63	M8	73.5	19	36.5	40	37.5	8	26.5	15	16	13.5	20	29
255436*	ERW.63-SST-p-M8x20.*	63	M8	73.5	19	36.5	40	37.5	8	26.5	15	20	13.5	20	30
255441*	ERW.63-SST-p-M8x25.*	63	M8	73.5	19	36.5	40	37.5	8	26.5	15	25	13.5	20	31
255446*	ERW.63-SST-p-M8x30.*	63	M8	73.5	19	36.5	40	37.5	8	26.5	15	30	13.5	20	33
255451*	ERW.63-SST-p-M8x35.*	63	M8	73.5	19	36.5	40	37.5	8	26.5	15	35	13.5	20	35
255456*	ERW.63-SST-p-M8x40.*	63	M8	73.5	19	36.5	40	37.5	8	26.5	15	40	13.5	20	37
255461*	ERW.63-SST-p-M8x45.*	63	M8	73.5	19	36.5	40	37.5	8	26.5	15	45	13.5	20	38
255466*	ERW.63-SST-p-M8x50.*	63	M8	73.5	19	36.5	40	37.5	8	26.5	15	50	13.5	20	39
255471*	ERW.63-SST-p-M8x60.*	63	M8	73.5	19	36.5	40	37.5	8	26.5	15	60	13.5	20	42
255476*	ERW.63-SST-p-M8x70.*	63	M8	73.5	19	36.5	40	37.5	8	26.5	15	70	13.5	20	45
255601*	ERW.78-SST-p-M8x-20.*	78	M8	90.5	24.5	42	45.5	47	12	30	19	20	16	24	48
255603*	ERW.78-SST-p-M8x-25.*	78	M8	90.5	24.5	42	45.5	47	12	30	19	25	16	24	49
255605*	ERW.78-SST-p-M8x-30.*	78	M8	90.5	24.5	42	45.5	47	12	30	19	30	16	24	50
255607*	ERW.78-SST-p-M8x-40.*	78	M8	90.5	24.5	42	45.5	47	12	30	19	40	16	24	52
255609*	ERW.78-SST-p-M8x-45.*	78	M8	90.5	24.5	42	45.5	47	12	30	19	45	16	24	53
255611*	ERW.78-SST-p-M8x-50.*	78	M8	90.5	24.5	42	45.5	47	12	30	19	50	16	24	54
255617*	ERW.78-SST-p-M8x-70.*	78	M8	90.5	24.5	42	45.5	47	12	30	19	70	16	24	58
255716*	ERW.78-SST-p-M10x-20.*	78	M10	90.5	24.5	42	45.5	47	12	30	19	20	16	24	55
255726*	ERW.78-SST-p-M10x-30.*	78	M10	90.5	24.5	42	45.5	47	12	30	19	30	16	24	61
255731*	ERW.78-SST-p-M10x-35.*	78	M10	90.5	24.5	42	45.5	47	12	30	19	35	16	24	63
255736*	ERW.78-SST-p-M10x-40.*	78	M10	90.5	24.5	42	45.5	47	12	30	19	40	16	24	66
255741*	ERW.78-SST-p-M10x-50.*	78	M10	90.5	24.5	42	45.5	47	12	30	19	50	16	24	70
255746*	ERW.78-SST-p-M10x-60.*	78	M10	90.5	24.5	42	45.5	47	12	30	19	60	16	24	75
255771*	ERW.78-SST-p-M12x-30.*	78	M12	90.5	24.5	42	45.5	47	12	30	19	30	16	24	71
255773*	ERW.78-SST-p-M12x-35.*	78	M12	90.5	24.5	42	45.5	47	12	30	19	35	16	24	75
255781*	ERW.78-SST-p-M12x-40.*	78	M12	90.5	24.5	42	45.5	47	12	30	19	40	16	24	78
255786*	ERW.78-SST-p-M12x-50.*	78	M12	90.5	24.5	42	45.5	47	12	30	19	50	16	24	84
255893*	ERW.78-SST-p-M12x-70.*	78	M12	90.5	24.5	42	45.5	47	12	30	19	70	16	24	99

Clamping handles