



## Features

- 1.8mm Contact Gap Available
- Wide Contact Terminals for Better Heat Transfer
- Made in Accordance to IEC 60335-1
- 1.8mm Contact Gap Model Meets IEC 62109-2
- Meets EN61095; AC7a at 85°C
- UL/cUL Recognized

**UL**<sup>®</sup> US  
E197852



## Contact Data\*

Contact Configuration	UL Rating	Contact Gap	Coil Power
1A	NO: 35A @ 250/277VAC, Resistive, 50K cycles, 85°C	1.8mm	2.25W
1A & 1C	NO: 60A @ 250/277VAC; General Purpose & Resistive, 20K cycles, 40°C NC: 35A @ 250/277VAC; General Purpose & Resistive, 20K cycles, 40°C	1.1mm	1.2W
Contact Resistance	< 30 milliohms initial		
Contact Material	AgSnO <sub>2</sub>		
Maximum Switching Power	13850VA		
Maximum Switching Voltage	277VAC		
Maximum Switching Current	50A		

## Coil Data DC Parameters\*

Coil Voltage VDC		Coil Resistance Ω +/- 10%		Pick Up Voltage VDC (max)	Release Voltage VDC (min)	Coil Power W	Operate Time ms	Release Time ms
Rated	Max	1.2W	2.25W	75% of rated voltage	10% of rated voltage			
12	15.6	120	64	9.0	1.2	1.2W 2.25W	≤15	≤10
24	31.2	480	256	18.0	2.4			

## General Data\*

Electrical Life @ rated load	100K cycles, average
Mechanical Life	500K cycles, average
Insulation Resistance	1000M Ω min. @ 500VDC initial
Dielectric Strength	Coil to Contact 4000V rms min. @ sea level
	Contact to Contact 2500V rms min. @ sea level
Shock Resistance	98m/s <sup>2</sup> for 11 ms
Vibration Resistance	1.50mm double amplitude 10~55Hz
Operating Temperature	-40°C to +125°C
Storage Temperature	-40°C to +155°C
Solderability	260°C for 5 s
Weight	30g

\* Values can change due to the switching frequency, desired reliability levels, environmental conditions and in-rush load levels. It is recommended to test actual load conditions for the application. It is the user's responsibility to determine the performance suitability for their specific application. The use of any coil voltage less than the rated coil voltage may compromise the operation of the relay.

## Ordering Information

1. Series	J115F1K	1A	H	12VDC	S	K	2.25
J115F1K							
2. Contact Arrangement	1A = SPST N.O. 1C = SPDT						
3. Contact Raging	H = 35A with 1.8mm contact gap <sup>1</sup> M = 60A with 1.1 standard gap <sup>2</sup>						
4. Coil Voltages	12VDC 24VDC						
5. Sealing Options	S = Sealed, standard						
6. Contact Material	Blank = AgSnO <sub>2</sub>						
7. Contact Gap	Blank = Standard Contact Gap K = 1.8mm Contact Gap						
8. Coil Power	1.2 = 1.2W 2.25 = 2.25W						

**NOTE:**

- 1 – Only available with 1A contact arrangement, 1.8mm contact gap, 2.25W coil power
- 2 – Only available with standard contact gap, 1.2W coil power

## Dimensions

Units = mm

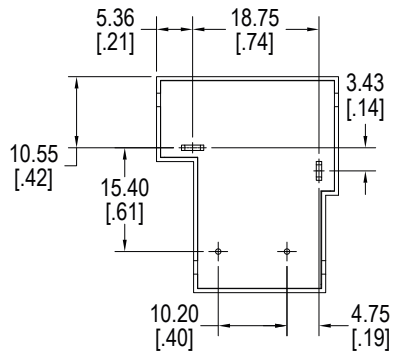
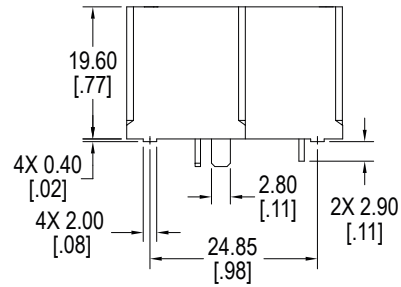
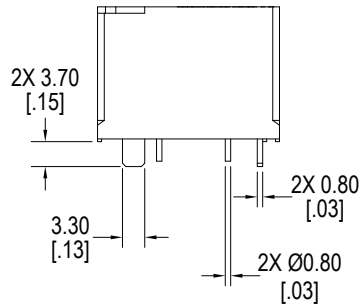
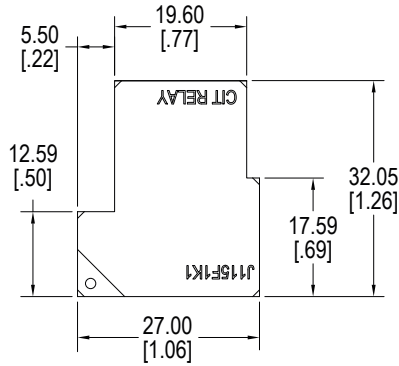

## Schematics & PC Layouts

Bottom Views

