

NS 15 PERF 500MM - DIN rail perforated



1207645

<https://www.phoenixcontact.com/us/products/1207645>

Please be informed that the data shown in this PDF document is generated from our online catalog. Please find the complete data in the user documentation. Our general terms of use for downloads are valid.



DIN rail perforated, acc. to EN 60715, material: Steel, galvanized, passivated with a thick layer, Standard profile, color: silver

Commercial data

| | |
|--------------------------------------|---------------|
| Item number | 1207645 |
| Packing unit | 1 pc |
| Minimum order quantity | 20 pc |
| Sales key | BH84 |
| Product key | BH8421 |
| GTIN | 4046356366038 |
| Weight per piece (including packing) | 999 g |
| Weight per piece (excluding packing) | 999 g |
| Customs tariff number | 72166190 |
| Country of origin | DE |

NS 15 PERF 500MM - DIN rail perforated



1207645

<https://www.phoenixcontact.com/us/products/1207645>

Technical data

Product properties

| | |
|--------------|----------|
| Product type | DIN rail |
|--------------|----------|

Dimensions

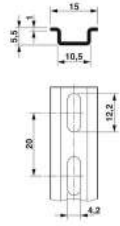
| | |
|---------------------|--|
| Dimensional drawing |  |
| Width | 15 mm |
| Hole width | 12.2 mm |
| Height | 5.5 mm |
| Hole height | 4.2 mm |
| Length | 500 mm |
| Drill hole spacing | 20 mm |

Material specifications

| | |
|----------|---|
| Color | silver |
| Material | Steel |
| Coating | galvanized, passivated with a thick layer |

Standards and regulations

| | |
|----------------------------------|------------------|
| Connection in acc. with standard | IEC / EN |
| Tests | acc. to EN 60715 |

NS 15 PERF 500MM - DIN rail perforated

1207645

<https://www.phoenixcontact.com/us/products/1207645>



Drawings

Dimensional drawing

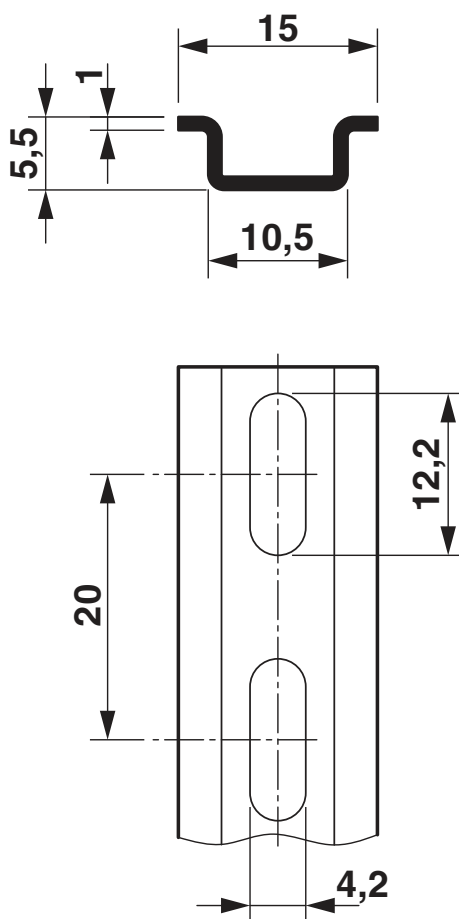

NS 15 PERF 500MM - DIN rail perforated



1207645

<https://www.phoenixcontact.com/us/products/1207645>

Classifications

ECLASS

| | |
|-------------|----------|
| ECLASS-11.0 | 27400602 |
| ECLASS-13.0 | 27400602 |
| ECLASS-12.0 | 27400602 |

ETIM

| | |
|----------|----------|
| ETIM 8.0 | EC001285 |
|----------|----------|

UNSPSC

| | |
|-------------|----------|
| UNSPSC 21.0 | 39121700 |
|-------------|----------|

NS 15 PERF 500MM - DIN rail perforated



1207645

<https://www.phoenixcontact.com/us/products/1207645>

Environmental product compliance

| | |
|------------|---|
| China RoHS | Environmentally friendly use period: unlimited = EFUP-e No hazardous substances above threshold values |
|------------|---|

Phoenix Contact 2023 © - all rights reserved
<https://www.phoenixcontact.com>

Phoenix Contact USA
586 Fulling Mill Road
Middletown, PA 17057, United States
(+717) 944-1300
info@phoenixcon.com