

REVISION RECORD				
REV	ECO	DESCRIPTION	DRFT	CHKD

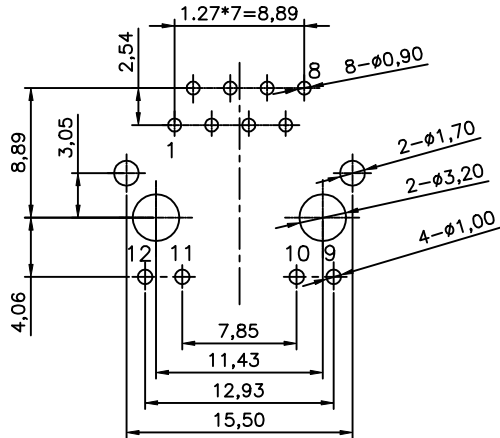

PC Board Layout Component Side Shown
PC Board = 1.60 mm t

NOTES:

ELECTRICAL:

- VOLTAGE RATING : 125 VAC RMS .
- CURRENT RATING : 1.5 AMP .
- CONTACT RESISTANCE : 45 MILLIOHMS MAX.
- INSULATION RESISTANCE: 1000 MEGOHMS MIN @ 500 VDC.
- DIELECTRIC STRENGTH : 1000 VAC RMS 60Hz, 1MIN.

MECHANICAL:

- HOUSING MATERIAL : GLASS FILLED POLYESTER UL94V-0.
- CONTACT MATERIAL : PHOSPHOR BRONZE t=0.35mm.
- PLATING : GOLD PLATING OVER NICKEL.
- OPERATING LIFE : 750 CYCLES MIN.
- PCB RETENTION PRE-SOLDER : 1 LB MIN.
- PCB RETENTION POST-SOLDER: 10 LBS MIN.

ENVIRONMENTAL:

- STORAGE : -40°C TO +85°C.
- OPERATION: 0°C TO 70°C.
- WAVE SOLDERING TEMPERATURE: 230~250°C(3~5 SECONDS)

MATES WITH MODULAR PLUG CONFORMING TO
FCC PART 68, SUBPART F.

CUL FILE NO. E163191

ROHS BPART NUMBER: E5J88-XXLXPX-L

- | | | |
|---------------|--------------------|---------------------|
| 1-LED1:GREEN | LED2:YELLOW | 1-3u" 2-6u" |
| 2-LED1:GREEN | LED2:GREEN | 3-15u" 4-30u"5-50u" |
| 3-LED1:YELLOW | LED2:GREEN | 0-W/O "FRE"LOGO |
| E-LED1:GREEN | LED2:RED | 2-W/ "FRE"LOGO |
| | 1-W/ O TAB | |
| | 2-W/ TOP TABS | |
| | 4-W/ TOP&SIDE TABS | |

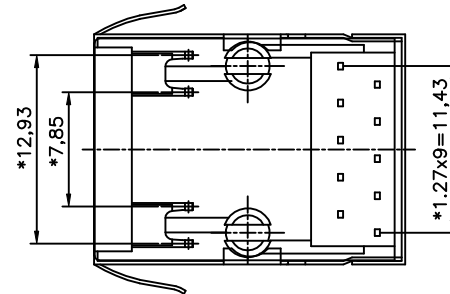
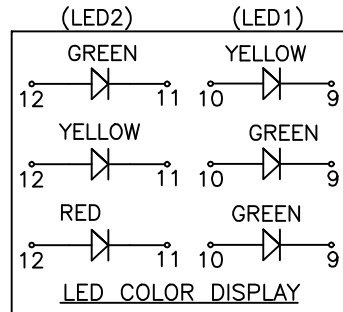
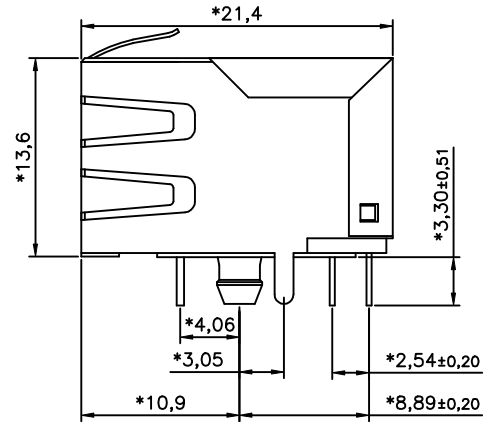
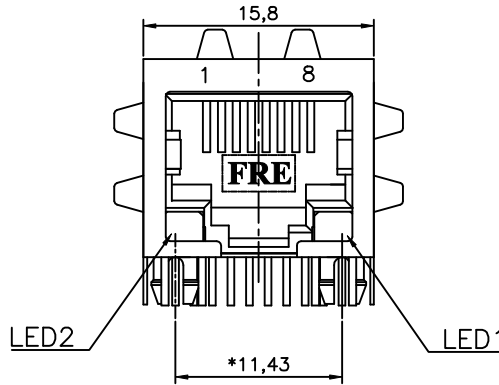

DETACHED LISTS	MM (INCH)	DFTO YANGLAN DATE 08/03/05	FULL RISE ELECTRONIC CO., LTD	
	TOLERANCES EXCEPT AS NOTED	CHKD SAMMY DATE 2005/08/08		
	MM	MFO DATE	TITLE SIDE ENTRY LED JACK	
	.0 ±0.20 ±	APPV LUSHENG DATE 2005/08/08		
.00 ±0.15 ±	MATERIAL :	DRAWING NO. GE5J3012-LC	SIZE A3	REV 0
.000 ±0.075 ±	ANGLES ± 0.5	QT'Y :	/PART NO. SEE NOTE	08/03/05
THIRD ANGLE PROJECTION	FINISH :	SCALE : 2.5 : 1	DO NOT SCALE DRAWING	SHEET 1 OF 1