

DESCRIPTION

Demonstration circuit 966 is an I/Q modulator featuring the LT[®]5568. The LT[®]5568 is a 700MHz to 1.05GHz direct I/Q modulator designed for high performance wireless applications, including wireless infrastructure. It may also be configured as an image reject upconverting mixer, by applying 90° phase-shifted signals to the I and Q inputs.

A high-speed, internally matched LO amplifier drives two double-balanced mixer cores, allowing the use of a low power, single-ended LO source. It allows direct modulation of an RF signal using differential baseband I and Q signals. It supports GSM, EDGE, CDMA, CDMA2000, W-CDMA, 64-QAM, OFDM and other modulation formats.

The I/Q baseband inputs consist of voltage-to-current converters that in turn drive double-balanced mixers. The outputs of these mixers are summed and applied to an on-chip RF transformer, which converts the differential

mixer signals to a 50Ω single-ended output. The four balanced I and Q base-band input ports are intended for DC coupling from a source with a common-mode voltage level of about 0.5V. The differential input impedance of the baseband inputs is approximately 100Ω, making them ideally suited for current-drive applications.

The LO path consists of an LO buffer with single-ended input, and precision quadrature generators which produce the LO drive for the mixers.

Demonstration circuit 966 is designed for an RF output frequency range from 700MHz to 1.05GHz.

Design files for this circuit board are available. Call the LTC factory.

LT is a registered trademark of Linear Technology Corporation.

QUICK START GUIDE FOR DEMONSTRATION CIRCUIT 966

HIGH LINEARITY DIRECT QUADRATURE MODULATOR

Table 1. Typical Performance Summary ($T_A = 25^\circ\text{C}$)

PARAMETER	CONDITION ($f_{\text{BB}} = 2\text{MHz}$, $f_{\text{LO}} = 850\text{MHz}$)	VALUE
Supply Voltage		4.5V to 5.25V
Supply Current	$V_{\text{CC}} = 5\text{V}$, EN = High	113 mA
Maximum Shutdown Current	$V_{\text{CC}} = 5\text{V}$, EN = Low	230 μA
RF Frequency Range		700 to 1050 MHz
Baseband Frequency Range		DC to 380 MHz
LO Input Return Loss	$Z_0 = 50\Omega$, $P_{\text{LO}} = 0\text{dBm}$	13 dB
RF Output Return Loss	$Z_0 = 50\Omega$	30 dB
LO Input Power		-10 to +5 dBm
LO Frequency Range		700 to 1050 MHz
Conversion Gain	$P_{\text{RF}} = -10\text{dBm}$, $P_{\text{LO}} = 0\text{dBm}$, defined as $P_{\text{RF}}/P_{\text{BB}}$	-6.8 dB
Output 3 rd Order Intercept	2-Tone, $P_{\text{RF}} = -10\text{dBm/Tone}$, $\Delta f = 100\text{KHz}$, $P_{\text{LO}} = 0\text{dBm}$	+22.9 dBm
Output 2 nd Order Intercept	2-Tone, $P_{\text{RF}} = -10\text{dBm/Tone}$, $\Delta f = 100\text{KHz}$, $P_{\text{LO}} = 0\text{dBm}$	+63 dBm
Output 1dB Compression	$P_{\text{LO}} = 0\text{dBm}$	+8.3 dBm
LO leakage	$P_{\text{LO}} = 0\text{dBm}$	-43 dBm
Image Rejection	$P_{\text{LO}} = 0\text{dBm}$	-46 dBc

APPLICATION NOTE

RF FREQUENCY RANGE

No tuning is required for operation over the RF frequency range of 700 MHz to 1.05 GHz.

BASEBAND FREQUENCY RANGE

The baseband frequency range extends from DC to 3800 MHz (3dB bandwidth).

LO TO RF LEAKAGE

The LT[®]5568 offers excellent LO to RF leakage performance, typically -43 dBm.

TEST EQUIPMENT AND SETUP

Refer to Figure 1 for proper measurement equipment setup. Before performing measurements on the DUT, it is very important to evaluate the test system performance to ensure that: 1) distortion-free input signals are applied and 2) the spectrum analyzer internal distortion is minimized. Follow the guidelines below to do this.

Use high performance signal generators with low harmonic output (>75 dBc) for 2-tone measurements. The signal generators must provide 2 equal amplitude outputs in quadrature with one another. High quality combiners that provide broadband 50 ohm termination on all ports should be used. The combiners should have good port-to-port isolation (>30 dB) to prevent the signal generators from modulating each other and generating intermodulation products. Attenuators on the outputs of these generators can also be used to increase the effective port-to-port isolation.

The LO leakage may be further reduced by the introduction of small differential DC offsets ($V_{BBIP} - V_{BBIM}$, $V_{BBQP} - V_{BBQM}$) at the

baseband inputs, typically less than 10mV. These DC offsets may be introduced, for example, using the DC offset points shown in figure 1.

SIDETONE TO RF LEAKAGE

The LT[®]5568 also offers very good image rejection (sidetone suppression) at the RF port. The image rejection may be further enhanced by the introduction of small differential phase and amplitude offsets at the baseband inputs.

Spectrum analyzers can produce significant internal distortion products if they are overdriven. Sufficient spectrum analyzer input attenuation should be used to avoid saturating the instrument. A typical input 3rd order intercept point for a spectrum analyzer is +40 dBm, with 20 dB input attenuation applied. This is more than 10 dB above the intercept point of the DUT, and should yield accurate 3rd order distortion results.

QUICK START PROCEDURE

Demonstration circuit 966 is easy to set up to evaluate the performance of the LT[®]5568. Refer to Figure 1 for proper measurement equipment setup.

Follow the procedure below:

1. Connect all test equipment as shown in Figure 1.
2. Set the DC power supply's current limit to 150mA, and adjust output voltage to 5V.
3. Connect Vcc to the 5V DC supply, and then connect VCCEN to 5V; the modulator is enabled (on).
4. Set Signal Generator #1 to provide a 850MHz, 0dBm, CW signal to the demo board LO input port.
5. Set the Signal Generators #2 and #3 to provide two -10dBm CW signals to the combiner ports - one at 2MHz, and the other at 2.1MHz. For both generators, output B should lead output A by 90 degrees. These 2 signals must be in quadrature to drive the demo board properly. This is most conveniently accomplished by using signal generators with dual outputs with adjustable phase. An example is the HP3326A shown in Figure 1.
6. To measure 3rd order distortion and conversion gain, set the Spectrum Analyzer start and stop frequencies to 851.8MHz and 852.3MHz, respectively. Sufficient spectrum analyzer input attenuation should be used to avoid distortion in the instrument.
7. The 3rd order intercept point is equal to $(P_1 - P_3) / 2 + P_1$, where P_1 is the average power level of the two fundamental output tones at 852MHz and 852.1MHz; P_3 is the average power level of the two 3rd order products at 851.9MHz and 852.2MHz. All units are in dBm.
8. To measure 2nd order distortion, set the Spectrum Analyzer start and stop frequencies to 854MHz and 856MHz, respectively. Sufficient spectrum analyzer input attenuation should be used to avoid distortion in the instrument.
9. The 2nd order intercept point is equal to $2 * P_1 - P_2$, where P_1 is the power level of the fundamental output tone at 852MHz, P_2 is the 2nd order product at 854.1MHz. All units are in dBm.

QUICK START GUIDE FOR DEMONSTRATION CIRCUIT 966 HIGH LINEARITY DIRECT QUADRATURE MODULATOR

Figure 1. Proper Measurement Equipment Setup

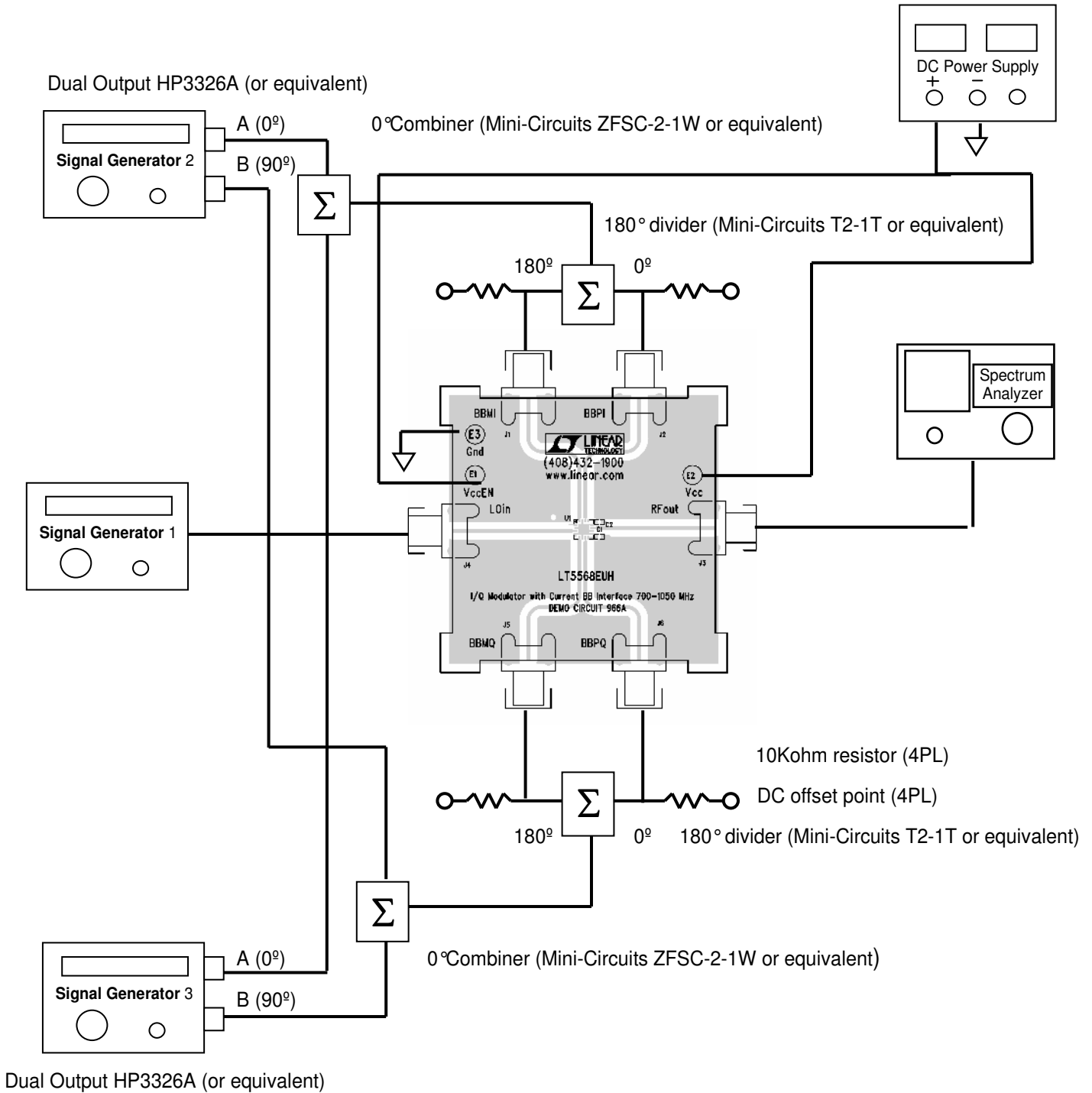

QUICK START GUIDE FOR DEMONSTRATION CIRCUIT 966

HIGH LINEARITY DIRECT QUADRATURE MODULATOR

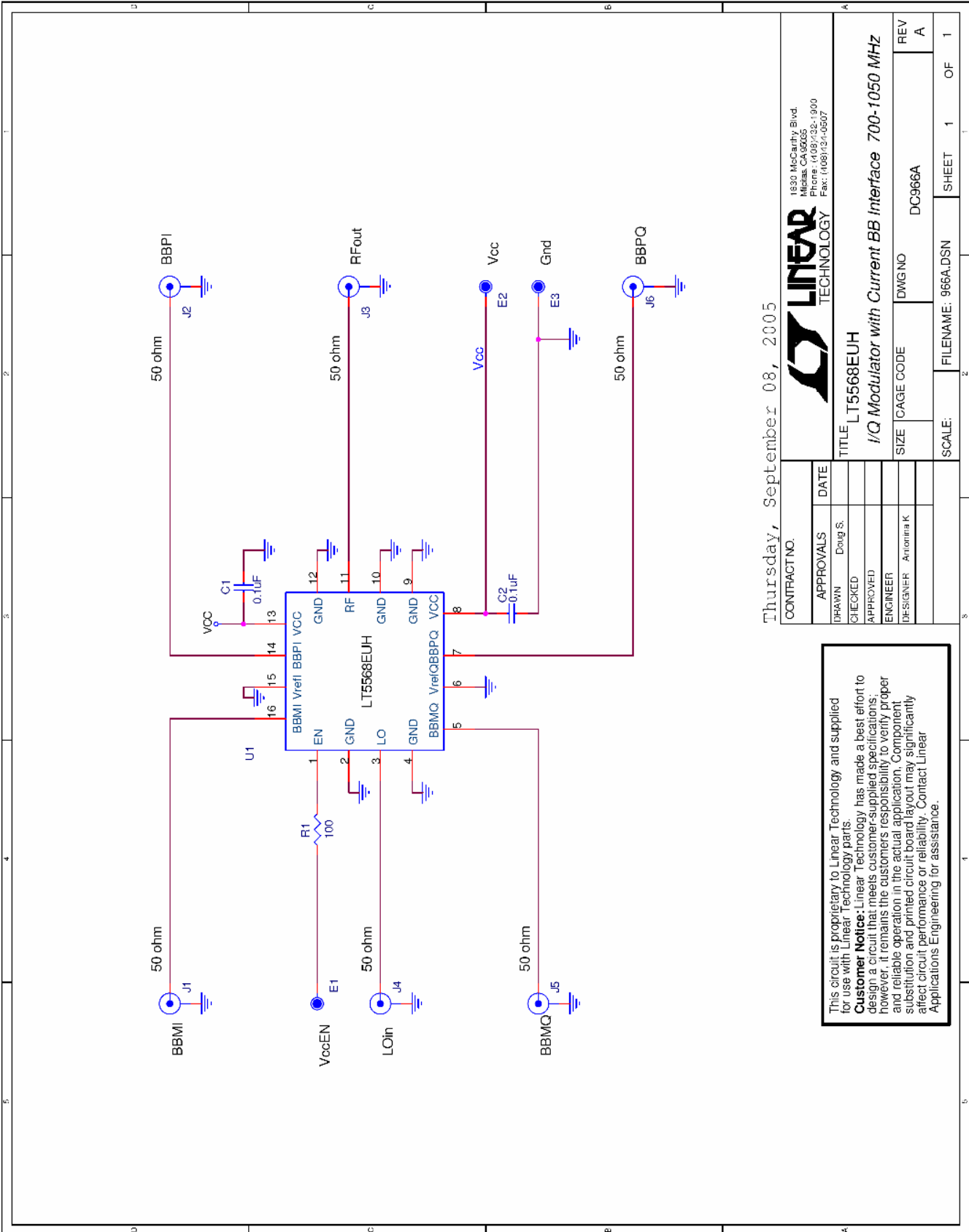

Thursday, September 08, 2005

CONTRACT NO.		1830 McCauley Blvd. Folsom, CA 95630 Tel: (916) 438-1000 Fax: (916) 438-9507	
APPROVALS	DATE	LINEAR TECHNOLOGY	
DRAWN: Doug S.		TITLE: LT5568EUH	
CHECKED:		I/Q Modulator with Current BB Interface 700-1050 MHz	
APPROVED:		SIZE: CAGE CODE	DWG NO: DC966A
ENGINEER:		REV: A	
DESIGNER: Anurupa K		SCALE:	FILENAME: 966A.DSN
		SHEET: 1	OF: 1

This circuit is proprietary to Linear Technology and supplied for use with Linear Technology parts.
Customer Notice: Linear Technology has made a best effort to design a circuit that meets customer-supplied specifications; however, it remains the customer's responsibility to verify proper and reliable operation in the actual application. Component substitution and printed circuit board layout may significantly affect circuit performance or reliability. Contact Linear Applications Engineering for assistance.