

# STS234XXXUXXX

## TVS Diode array ESD suppressor



### Product features

- Protects four I/O lines
- Low clamping voltage
- Low operating voltage
- Low capacitance
- Meets moisture sensitivity level (MSL) 3
- Molding compound flammability rating: UL 94V-0
- Termination finish: Tin

### Applications

- USB power and data line protection
- Digital video interface (DVI)
- Notebook computers
- Video graphics cards
- Monitors and flat panel displays
- 10/100/1000 ethernet
- SIM ports
- ATM interfaces

### Environmental compliance and general specifications

- IEC61000-4-2 (ESD)
  - Up to  $\pm 30$  kV (air)
  - Up to  $\pm 30$  kV (contact)
- IEC61000-4-5 (Lightning) Up to 24 A (8/20  $\mu$ s)



### Ordering part number

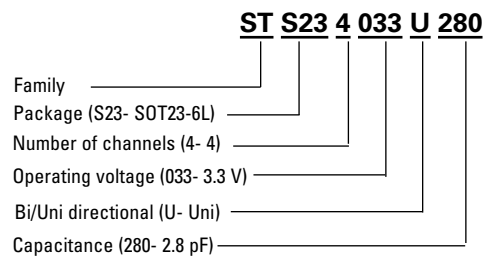

### Pin out/functional diagram

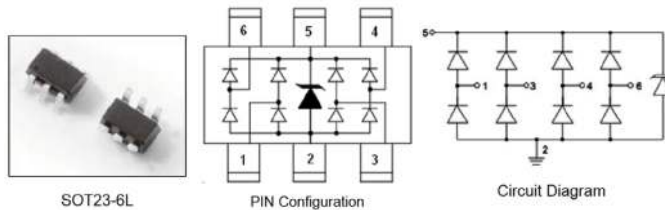

### Absolute maximum ratings

(+25 °C, RH=45%-75%, unless otherwise noted)

Parameter	Symbol	Value					Unit
		STS234033U280	STS234050U160	STS234050UL30	STS234050UL65	STS234050U150	
Peak pulse power dissipation on 8/20 μs waveform	$P_{pp}$	500	300	100	100	500	W
Peak pulse current on 8/20 μs waveform	$I_{pp}$	-	-	8	-	-	A
ESD per IEC 61000-4-2 (Air)	$V_{ESD}$	+/-30	+/-30	+/-20	+/-30	+/-30	kV
ESD per IEC 61000-4-2 (Contact)		+/-30	+/-30	+/-20	+/-30	+/-30	
Lead soldering temperature	$T_L$	+260 (10 seconds)	+260 (10 seconds)	+260 (10 seconds)	+260 (10 seconds)	+260 (10 seconds)	°C
Operating junction temperature range	$T_J$	-55 to +125	-55 to +125	-55 to +125	-55 to +125	-55 to +125	°C
Storage temperature range	$T_{STG}$	-55 to +150	-55 to +150	-55 to +150	-55 to +150	-55 to +150	°C

### Electrical characteristics

(+25 °C)

#### STS234033U280

Parameter	Test condition	Minimum	Typical	Maximum	Symbol (Units)
Reverse working voltage	pin 5 to pin 2	-	-	3.3	$V_{RWM}$ (V)
Reverse breakdown voltage	$I_r = 1$ mA pin 5 to pin 2	4.0	5.6	-	$V_{BR}$ (V)
Reverse leakage current	$V_{RWM} = 3.3$ V pin 5 to pin 2	-	-	1	$I_r$ (μA)
Forward voltage	$I_f = 10$ mA	-	0.8	1.2	$V_f$ (V)
Clamping voltage	$I_{pp} = 1$ A, $t_p = 8/20$ μs	-	7	10	$V_c$ (V)
		-	12	16	$V_c$ (V)
		-	14	18	$V_c$ (V)
		-	-	-	$V_c$ (V)
Junction capacitance	$V_{RWM} = 0$ V, $f = 1$ MHz Any I/O pin to Ground	-	2.8	5	$C_j$ (pF)
	$V_{RWM} = 0$ V, $f = 1$ MHz Between I/O pins	-	1.5	2.5	$C_j$ (pF)

#### STS234050U160

Parameter	Test condition	Minimum	Typical	Maximum	Symbol (Units)
Reverse working voltage	-	-	-	5.0	$V_{RWM}$ (V)
Reverse breakdown voltage	$I_r = 1$ mA	6.0	-	-	$V_{BR}$ (V)
Reverse leakage current	$V_{RWM} = 5$ V pin 5 to pin 2	-	-	5	$I_r$ (μA)
Forward voltage	$I_f = 10$ mA	-	1.2	-	$V_f$ (V)
Clamping voltage	$I_{pp} = 15$ A, $t_p = 8/20$ μs	-	22	24.8	$V_c$ (V)
Junction capacitance	$V_{RWM} = 0$ V, $f = 1$ MHz Any I/O pin to Ground	-	3	-	$C_j$ (pF)
	$V_{RWM} = 0$ V, $f = 1$ MHz Between I/O pins	-	1.6	-	$C_j$ (pF)

**STS234050UL30**

Parameter	Test condition	Minimum	Typical	Maximum	Symbol (Units)
Reverse working voltage	-	-	-	5.0	$V_{RWM}$ (V)
Reverse breakdown voltage	$I_T = 1$ mA	6.0	-	-	$V_{BR}$ (V)
Reverse leakage current	$V_{RWM} = 5$ V	-	-	1	$I_R$ ( $\mu$ A)
Forward voltage	$I_T = 10$ mA	-	0.8	1.0	$V_F$ (V)
Clamping voltage	$I_{PP} = 1$ A, $t_D = 8/20$ $\mu$ s	-	9.5	11	$V_C$ (V)
	$I_{PP} = 5$ A, $t_D = 8/20$ $\mu$ s	-	12.5	15	$V_C$ (V)
Junction capacitance	$V_{RWM} = 0$ V, $f = 1$ MHz Any I/O pin to Ground	-	0.65	0.8	$C_J$ (pF)
	$V_{RWM} = 0$ V, $f = 1$ MHz Between I/O pins	-	0.3	0.5	$C_J$ (pF)

**STS234050UL65**

Parameter	Test condition	Minimum	Typical	Maximum	Symbol (Units)
Reverse working voltage	-	-	-	5.0	$V_{RWM}$ (V)
Reverse breakdown voltage	$I_T = 1$ mA	6.0	8.0	10.0	$V_{BR}$ (V)
Reverse leakage current	$V_{RWM} = 5$ V	-	0.01	0.1	$I_R$ ( $\mu$ A)
Forward voltage	$I_T = 10$ mA	-	0.8	1.2	$V_F$ (V)
Clamping voltage	$I_{PP} = 1$ A, $t_D = 8/20$ $\mu$ s	-	9.5	11	$V_C$ (V)
	$I_{PP} = 8$ A, $t_D = 8/20$ $\mu$ s	-	11	13	$V_C$ (V)
Junction capacitance	$V_{RWM} = 0$ V, $f = 1$ MHz Any I/O pin to Ground	-	1.2	1.5	$C_J$ (pF)
	$V_{RWM} = 0$ V, $f = 1$ MHz Between I/O pins	-	0.65	0.75	$C_J$ (pF)

**STS234050U150**

Parameter	Test condition	Minimum	Typical	Maximum	Symbol (Units)
Reverse working voltage	pin 5 to pin 2	-	-	5.0	$V_{RWM}$ (V)
Reverse breakdown voltage	$I_T = 1$ mA pin 5 to pin 2	6.0	-	9.0	$V_{BR}$ (V)
Reverse leakage current	$V_{RWM} = 5$ V pin 5 to pin 2	-	-	0.5	$I_R$ ( $\mu$ A)
Forward voltage	$I_T = 10$ mA	-	-	1.2	$V_F$ (V)
Clamping voltage	$I_{PP} = 1$ A, $t_D = 8/20$ $\mu$ s	-	9	10	$V_C$ (V)
	$I_{PP} = 5$ A, $t_D = 8/20$ $\mu$ s	-	10	12	$V_C$ (V)
	$I_{PP} = 24$ A, $t_D = 8/20$ $\mu$ s	-	16	18	$V_C$ (V)
Junction capacitance	$V_{RWM} = 0$ V, $f = 1$ MHz Any I/O pin to Ground	-	3	3.5	$C_J$ (pF)
	$V_{RWM} = 0$ V, $f = 1$ MHz Between I/O pins	-	1.5	2	$C_J$ (pF)

**Mechanical parameters, pad layout- mm/inches**

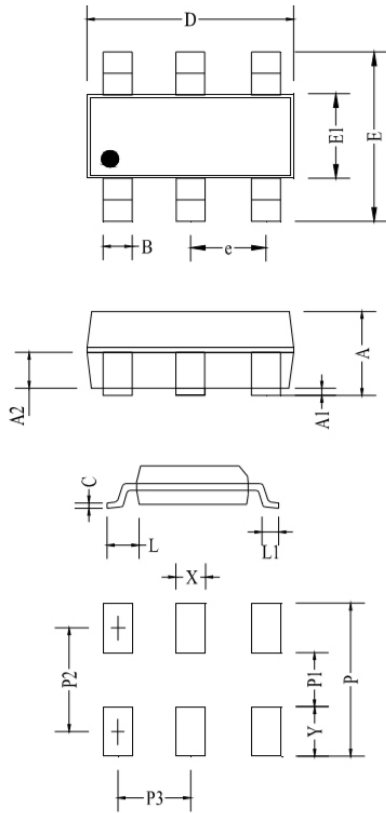

**Land Pattern**

Dimension	Millimeters		Inches	
	Minimum	Maximum	Minimum	Maximum
A	0.90	1.45	0.035	0.057
A1	0.00	0.15	0.000	0.006
A2	0.45	0.65	0.017	0.026
B	0.35	0.50	0.010	0.020
C	0.08	0.20	0.003	0.007
D	2.80	3.00	0.110	0.122
e	0.69	1.02	0.032	0.043
E1	1.50	1.75	0.060	0.069
E	2.80 BSC		0.110 BSC	
L1	0.35	0.60	0.013	0.024
L	0.60		0.024	
X	0.60		0.024	
Y	1.10		0.043	
P	3.60		0.141	
P1	1.40		0.055	
P2	2.50		0.098	
P3	0.95		0.037	

**Part marking**

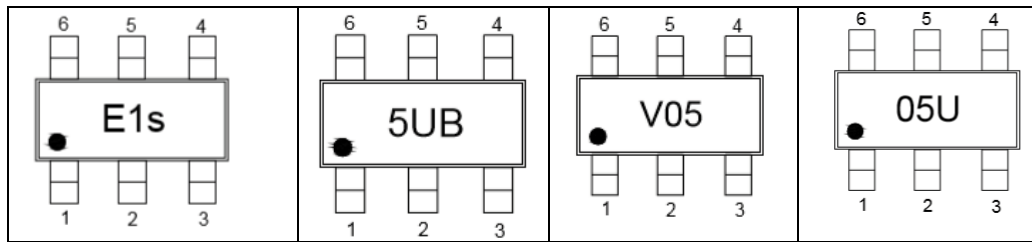

(STS234033U280)

(STS234050U160)

(STS234050UL30)

(STS234050UL65)

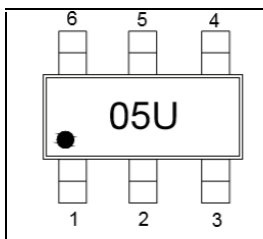

(STS234050U150)

**Packaging information mm/inches**

Drawing not to scale.

Supplied in tape and reel packaging, 3,000 parts per 7" diameter reel (EIA-481 compliant)

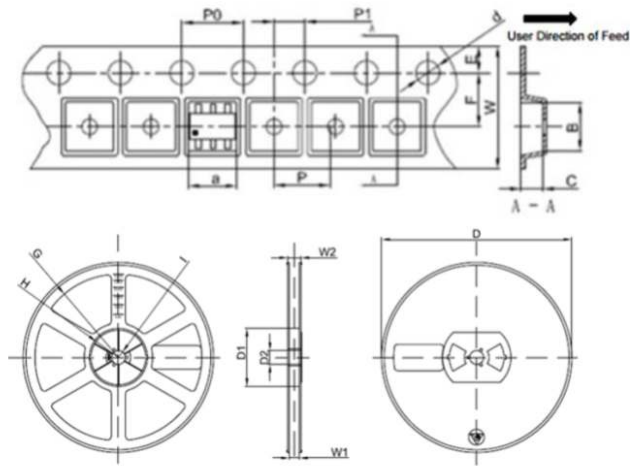

Symbol	Millimeter	Inches
	Typ.	Typ.
a	3.17	0.125
B	3.23	0.127
C	1.37	0.054
d	Φ1.55	Φ0.061
E	1.75	0.069
F	3.50	0.138
P0	4.00	0.157
P	4.00	0.157
P1	2.00	0.079
W	8.00	0.315
D	Φ180	Φ7.087
D1	60.00	2.632
D2	13.00	0.512
G	R78.00	R3.071
H	R25.60	R1.008
I	R6.50	R0.256
W1	9.50	0.374
W2	13.10	0.516

**Ratings and V-I characteristic curves** (+25 °C unless otherwise noted)

**V- I curve characteristics (Uni-directional)**

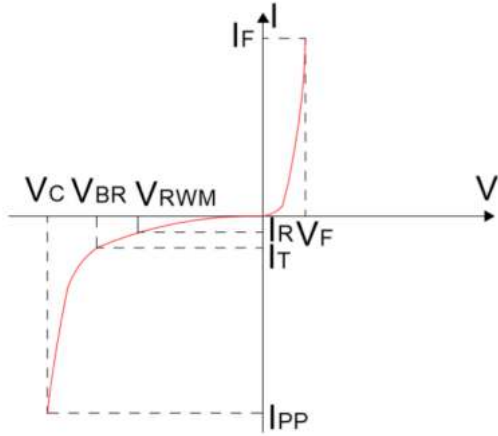

**Pulse waveform (8/20  $\mu$ s)**

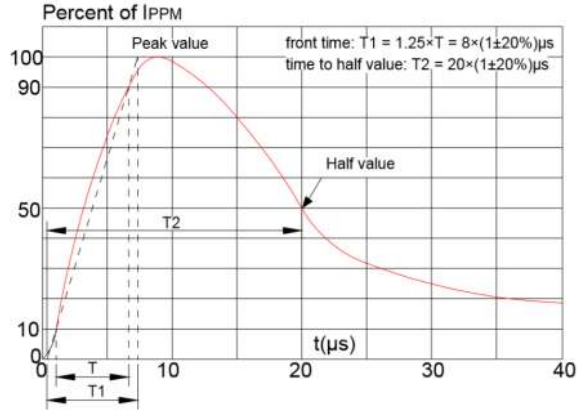

**Pulse derating curve**

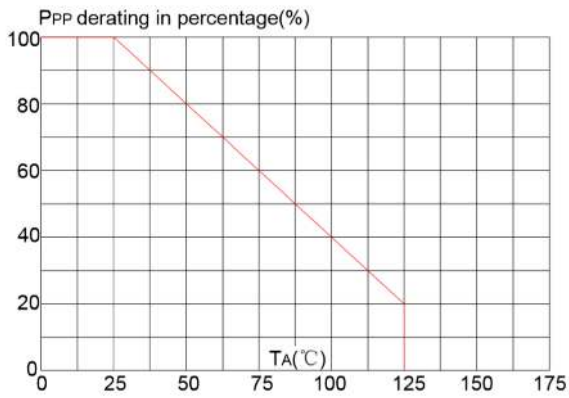

**ESD waveform**

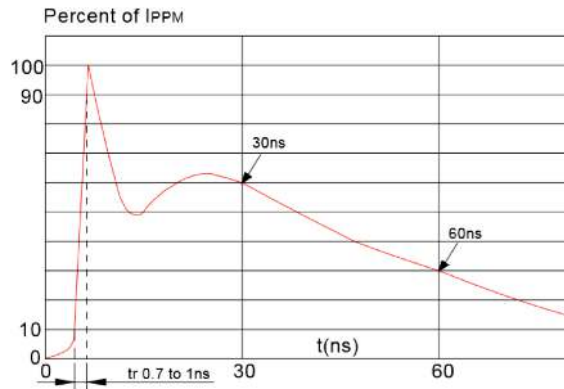

Solder reflow profile

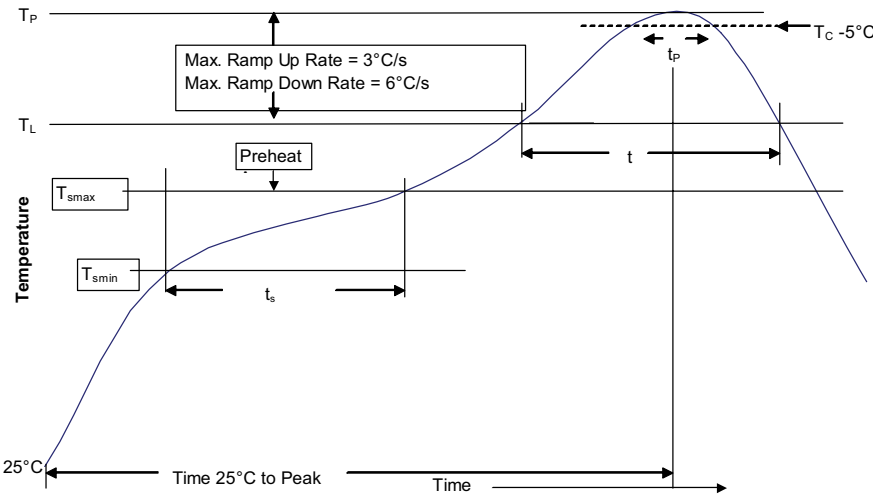

Table 1 - Standard SnPb solder ( $T_C$ )

Package thickness	Volume mm <sup>3</sup> <350	Volume mm <sup>3</sup> ≥350
<2.5 mm	235 °C	220 °C
≥2.5 mm	220 °C	220 °C

Table 2 - Lead (Pb) free solder ( $T_C$ )

Package thickness	Volume mm <sup>3</sup> <350	Volume mm <sup>3</sup> 350 - 2000	Volume mm <sup>3</sup> >2000
<1.6 mm	260 °C	260 °C	260 °C
1.6 – 2.5 mm	260 °C	250 °C	245 °C
>2.5 mm	250 °C	245 °C	245 °C

Reference J-STD-020

Profile feature	Standard SnPb solder	Lead (Pb) free solder
Preheat and soak		
• Temperature min. ( $T_{smin}$ )	100 °C	150 °C
• Temperature max. ( $T_{smax}$ )	150 °C	200 °C
• Time ( $T_{smin}$ to $T_{smax}$ ) ( $t_s$ )	60-120 seconds	60-120 seconds
Ramp up rate $T_L$ to $T_p$	3 °C/ second max.	3 °C/ second max.
Liquidous temperature ( $T_L$ )	183 °C	217 °C
Time ( $t_L$ ) maintained above $T_L$	60-150 seconds	60-150 seconds
Peak package body temperature ( $T_p$ )*	Table 1	Table 2
Time ( $t_p$ )* within 5 °C of the specified classification temperature ( $T_C$ )	20 seconds*	30 seconds*
Ramp-down rate ( $T_p$ to $T_L$ )	6 °C/ second max.	6 °C/ second max.
Time 25 °C to peak temperature	6 minutes max.	8 minutes max.

\* Tolerance for peak profile temperature ( $T_p$ ) is defined as a supplier minimum and a user maximum.

Life Support Policy: Eaton does not authorize the use of any of its products for use in life support devices or systems without the express written approval of an officer of the Company. Life support systems are devices which support or sustain life, and whose failure to perform, when properly used in accordance with instructions for use provided in the labeling, can be reasonably expected to result in significant injury to the user.

Eaton reserves the right, without notice, to change design or construction of any products and to discontinue or limit distribution of any products. Eaton also reserves the right to change or update, without notice, any technical information contained in this bulletin.

**Eaton**  
Electronics Division  
1000 Eaton Boulevard  
Cleveland, OH 44122  
United States  
Eaton.com/electronics

© 2022 Eaton  
All Rights Reserved  
Printed in USA  
Publication No. 11149  
April 2022

Eaton is a registered trademark.

All other trademarks are property of their respective owners.

Follow us on social media to get the latest product and support information.

